

This file is provided FREE OF CHARGE from the
electromaniacs.com community

You are free to distribute this file to other persons
who needs it , but without of charge

Also on <http://electromaniacs.com> you can find
thousands of service manuals , schematics free of
charge



Self Diagnosis
Supported model

SERVICE MANUAL

AE-6BA CHASSIS

MODEL	COMMANDER	DEST	CHASSIS NO.	MODEL	COMMANDER	DEST	CHASSIS NO.
KV-28FQ86B	RM-945	FR	SCC-Q83T-A	KV-32FQ86B	RM-945	FR	SCC-Q83U-A
KV-28FQ86E	RM-945	ESP	SCC-Q81W-A	KV-32FQ86E	RM-945	ESP	SCC-Q81X-A
				KV-32FQ86K	RM-945	OIRT	SCC-Q82M-A
				KV-32FQ86U	RM-945	UK	SCC-Q84T-A

FD Trinitron

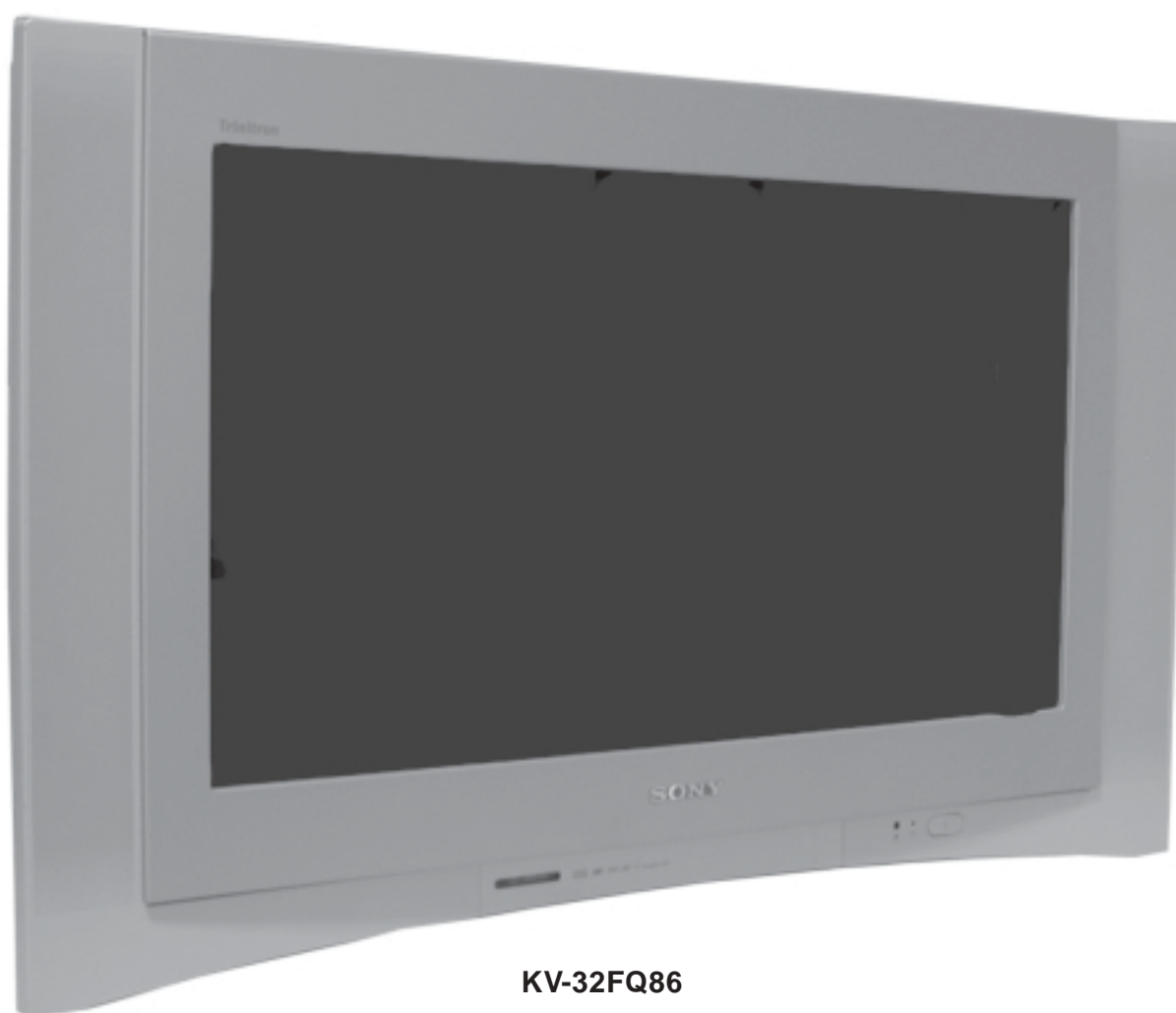

KV-32FQ86



RM-945

TRINITRON[®] COLOR TV
SONY[®]

TABLE OF CONTENTS

<i>Section</i>	<i>Title</i>	<i>Page</i>	<i>Section</i>	<i>Title</i>	<i>Page</i>
	Caution	3	5. DIAGRAMS		
	Specifications	4	5-1.	Block Diagrams (1)	25
	Connectors	6		Block Diagrams (2)	26
	Self Diagnostic Software	7		Block Diagrams (3)	27
				Block Diagrams (4)	28
1. GENERAL			5-2.	Circuit Board Location	28
	Switching On the TV and Automatically Tuning	8	5-3.	Schematic Diagrams and Printed Wiring Boards	28
	Introducing and Using the Menu System	9		* A Board Schematic	30
	The Picture Adjustment Menu	9		* A Board PWB	33
	The Sound Adjustment Menu	10		* B Board Schematic	35
	PAP (Picture and Picture)	10		* B Board PWB	37
	Teletext	11		* D2 Board Schematic	38
	Remote Control Configuration for VCR or DVD	11		* D2 Board PWB	37
	Technical Specifications	12		* F1 Board Schematic	39
	Lifting the TV Set	12		* F1 Board PWB	40
	Troubleshooting	13		* H1 Board Schematic	39
				* H1 Board PWB	40
				* VM Board Schematic	39
				* VM Board PWB	40
				* G Board Schematic	41
				* G Board PWB	40
				* C Board Schematic	42
				* C Board PWB	43
				* J Board Schematic	44
				* J Board PWB	43
				* D Board Schematic	46
				* D Board PWB	45
			5-4.	Semiconductors	47
			5-5.	IC Blocks	49
2. DISASSEMBLY			6. EXPLODED VIEWS		
2-1.	Rear Cover Removal	14	6-1.	Chassis	51
2-2.	Speaker Connector Disconnection.....	14	6-2.	Picture Tube	52
2-3.	Chassis Removal and Refitting	14			
2-4.	Service Position	15	7. ELECTRICAL PARTS LIST		53
2-5.	G Board Removal	15			
2-6.	D2 Board Removal	15			
2-7.	D Board Removal	15			
2-8.	Picture Tube Removal	16			
	Bottom Plates	17			
3. SET-UP ADJUSTMENTS					
3-1.	Beam Landing	18			
3-2.	Convergence	19			
3-3.	Focus Adjustment	21			
3-4.	Screen (G2), White Balance	21			
4. CIRCUIT ADJUSTMENTS					
4-1.	Electrical Adjustments	22			
4-2.	Test Mode 2	24			

CAUTION

SHORT CIRCUIT THE ANODE OF THE PICTURE TUBE AND THE ANODE CAP TO THE METAL CHASSIS, CRT SHIELD, OR THE CARBON PAINTED ON THE CRT, AFTER REMOVAL OF THE ANODE CAP.

WARNING !!

AN ISOLATION TRANSFORMER SHOULD BE USED DURING ANY SERVICE WORK TO AVOID POSSIBLE SHOCK HAZARD DUE TO LIVE CHASSIS, THE CHASSIS OF THIS RECEIVER IS DIRECTLY CONNECTED TO THE POWER LINE.

SAFETY-RELATED COMPONENT WARNING !!

COMPONENTS IDENTIFIED BY SHADING AND MARKED Δ ON THE SCHEMATIC DIAGRAMS, EXPLODED VIEWS AND IN THE PARTS LIST ARE CRITICAL FOR SAFE OPERATION. REPLACE THESE COMPONENTS WITH SONY PARTS WHOSE PART NUMBERS APPEAR AS SHOWN IN THIS MANUAL OR IN SUPPLEMENTS PUBLISHED BY SONY.

ATTENTION

APRES AVOIR DECONNECTE LE CAP DE L'ANODE, COURT-CIRCUITER L'ANODE DU TUBE CATHODIQUE ET CELUI DE L'ANODE DU CAP AU CHASSIS METALLIQUE DE L'APPAREIL, OU AU COUCHE DE CARBONE PEINTE SUR LE TUBE CATHODIQUE OU AU BLINDAGE DU TUBE CATHODIQUE.

ATTENTION !!

AFIN D'EVITER TOUT RISQUE D'ELECTROCUTION PROVENANT D'UN CHÂSSIS SOUS TENTION, UN TRANSFORMATEUR D'ISOLEMENT DOIT ETRE UTILISÉ LORS DE TOUT DÉPANNAGE LE CHÂSSIS DE CE RÉCEPTEUR EST DIRECTMENT RACCORDÉ À L'ALIMENTATION SECTEUR.

ATTENTION AUX COMPOSANTS RELATIFS À LA SECURITÉ!!

LES COMPOSANTS IDENTIFIÉS PAR UNE TRAME ET PAR UNE MARQUE Δ SUR LES SCHÉMAS DE PRINCIPE, LES VUES EXPLOSÉES ET LES LISTES DE PIÈCES SONT D'UNE IMPORTANCE CRITIQUE POUR LA SÉCURITÉ DU FONCTIONNEMENT, NE LES REMPLACER QUE PAR DES COMPOSANTS SONY DONT LE NUMÉRO DE PIÈCE EST INDIQUÉ DANS LE PRÉSENT MANUEL OU DANS DES SUPPLÈMENTS PUBLIÉS PAR SONY.

CAUTION

Lead Free Soldered Boards

The circuit boards listed below [Table 1] used in these models may have been processed using Lead Free Solder. The boards are identified by the LF logo located close to the board designation e.g. F1, H1 etc [see examples]. The servicing of these boards requires special precautions to be taken as outlined below.



example 1

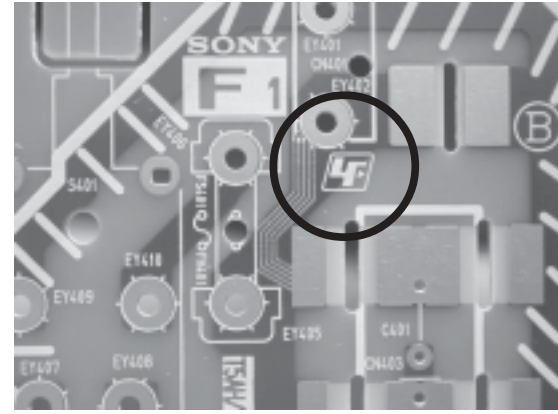

example 2

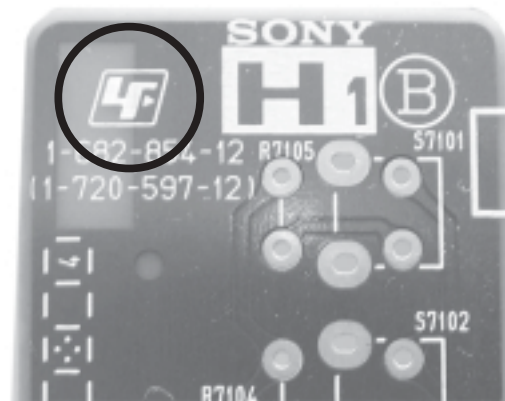

Table 1

Board	Function
A	Audio, Deflection, Tuner, Regulators, J,B Interface
B	Backend, Scanrate, LVDS, A_ Interface
C	R, G, B Out
D	Deflection
D2	Smart Mode Deflection
F1	Power Switch/Fuse/SIRCS/Standby LED
G	Power Supply
H1	Front AV Input/Headphone and Control Switches
J	AV Scart I/O Switching and Sockets
VM	Velocity Modulation

It is strongly recommended to use Lead Free Solder material in order to guarantee optimal quality of new solder joints. Lead Free Solder is available under the following part numbers :

Partnumber	Diameter	Remarks
7-640-005-19	0.3mm	0.25Kg
7-640-005-20	0.4mm	0.50Kg
7-640-005-21	0.5mm	0.50Kg
7-640-005-22	0.6mm	0.25Kg
7-640-005-23	0.8mm	1.00Kg
7-640-005-24	1.0mm	1.00Kg
7-640-005-25	1.2mm	1.00Kg
7-640-005-26	1.6mm	1.00Kg

Due to the higher melting point of Lead Free Solder the soldering iron tip temperature needs to be set to 370 degrees centigrade. This requires soldering equipment capable of accurate temperature control coupled with a good heat recovery characteristics.

For more information on the use of Lead Free Solder, please refer to <http://www.sony-training.com>

ITEM MODEL	Television System	Stereo System	Channel Coverage	Color System
B	B/G/H, D/K, I, L	GERMAN/NICAM Stereo	VHF : E2-E12, R1-R12, S01-S03, F02-F10 , B-Q UHF : E21-E69, F21-F69, B21-B69, R21-R69 CABLE TV : S01-S20 HYPER : S21-S41	PAL, SECAM NTSC4.43, NTSC3.58 (VIDEO IN)
E	B/G/H, D/K	GERMAN/NICAM Stereo	VHF : E2-E12, R1-R12, S01-S03, UHF : E21-E69, R21-R69 CABLE TV : S01-S20 HYPER : S21-S41	PAL, SECAM NTSC4.43, NTSC3.58 (VIDEO IN)
K	B/G/H, D/K	GERMAN/NICAM Stereo	VHF : E2-E12, R1-R12 , S01-S03 UHF : E21-E69, R21-R69 CABLE TV : S01-S20 HYPER : S21-S41	PAL, SECAM NTSC4.43, NTSC3.58 (VIDEO IN)
U	I	NICAM Stereo	I UHF : B21-B69	PAL, SECAM NTSC4.43, NTSC3.58 (VIDEO IN)

Picture Tube	Flat Display FD Trinitron WIDE:	Sound output	
	Approx 71 cm (28 inches) (KV-28FQ86)	Right and Left speaker	2x20W (Music Power) 2x10W (RMS)
	Approx 82 cm (32 inches) (KV-32FQ86)	Sub Woofer	1x30W (Music Power) 1x15W (RMS)
Input/Output Terminals [REAR]		General Specifications	
1: 21-pin Euro connector (CENELEC standard)	Inputs for Audio and Video signals. Inputs for RGB. Outputs of TV Video and Audio signals.	Power Requirements	220 - 240V
		Power Consumption	130W/0.5W
2: 21-pin Euro connector	Inputs for Audio and Video signals. Inputs for RGB. Outputs of TV Video and Audio signals. (Monitor Out)	Dimensions	Approx 789x533x510mm (KV-28FQ86) Approx 910x586x586mm (KV-32FQ86)
		Weight	Approx 45kg (KV-28FQ86) Approx 64kg (KV-32FQ86)
3: 21-pin Euro connector	Inputs for Audio and Video signals. Inputs for S Video. Outputs of TV Video and Audio signals. (selectable), Smartlink Interface	Supplied Accessories	RM-945 Remote Commander (1) IEC designated R6 battery (2)
Phono Jacks	Output Connectors variable for Audio Signals	Other Features	100 Hz picture, Digital Plus, NexTView, Teletext, Smartlink, BBE Digital, Dolby Virtual, PAP, ACI
Input/Output Terminals [FRONT]		Remote Control System : Infrared Control	
Headphone jack	stereo mini jack	Power requirements	3V dc 2 batteries IEC designation R6 (size AA)
Audio inputs	phono jacks		
Video inputs	phono jacks		
S Video input	4 pin DIN		
Design and specifications are subject to change without notice.			

Model Name Item	KV-28FQ86B	KV-28FQ86E	KV-32FQ86B	KV-32FQ86E	KV-32FQ86K	KV-32FQ86U
Pal Comb	OFF	OFF	OFF	OFF	OFF	OFF
PAP	ON	ON	ON	ON	ON	ON
RGB Priority	ON	ON	ON	ON	ON	ON
Woofer Box	ON	ON	ON	ON	ON	ON
Scart 1	ON	ON	ON	ON	ON	ON
Scart 2	ON	ON	ON	ON	ON	ON
Scart 3	ON	ON	ON	ON	ON	ON
Front in (4)	ON	ON	ON	ON	ON	ON
Projector	OFF	OFF	OFF	OFF	OFF	OFF
Norm B/G	ON	ON	ON	ON	ON	OFF
Norm I	ON	OFF	ON	OFF	OFF	ON
Norm D/K	ON	ON	ON	ON	ON	OFF
Norm AUS	OFF	OFF	OFF	OFF	OFF	OFF
Norm L	ON	OFF	ON	OFF	OFF	OFF
Norm SAT	OFF	OFF	OFF	OFF	OFF	OFF
Norm M	OFF	OFF	OFF	OFF	OFF	OFF
Teletext	ON	ON	ON	ON	ON	ON
Nicam Stereo	ON	ON	ON	ON	ON	ON

WARNING (UK Models only)

The flexible mains lead is supplied connected to a **B.S. 1363** fused plug having a fuse of **5 AMP** rating. Should the fuse need to be replaced, use a **5AMP FUSE** approved by ASTA to **BS 1362**, ie one that carries the  mark.

IF THE PLUG SUPPLIED WITH THIS APPLIANCE IS NOT SUITABLE FOR THE OUTLET SOCKETS IN YOUR HOME, IT SHOULD BE CUT OFF AND AN APPROPRIATE PLUG FITTED. THE PLUG SEVERED FROM THE MAINS LEAD MUST BE DESTROYED AS A PLUG WITH BARED WIRES IS DANGEROUS IF ENGAGED IN A LIVE SOCKET.

When an alternative type of plug is used, it should be fitted with a **5 AMP FUSE**, otherwise the circuit should be protected by a **5AMP FUSE** at the distribution board.

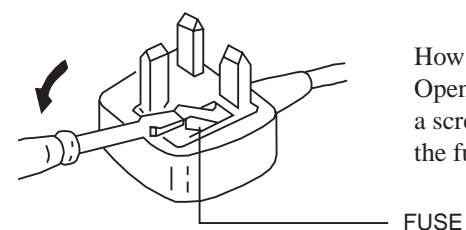

How to replace the fuse.
Open the fuse compartment with a screwdriver blade and replace the fuse.

21 pin connector

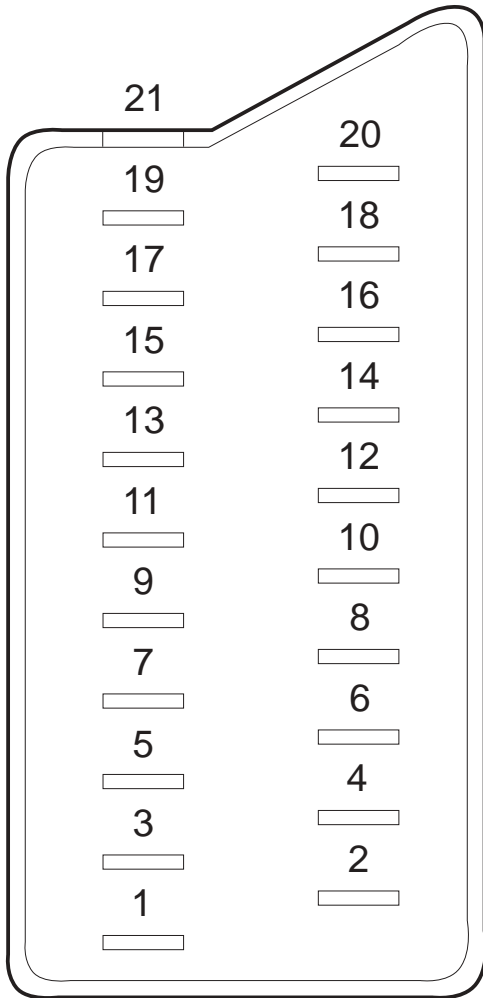

Pin No	1	2	3	Signal	Signal level
1	○	○	○	Audio output B (right)	Standard level : 0.5V rms Output impedance : Less than 1kohm*
2	○	○	○	Audio input B (right)	Standard level : 0.5V rms Output impedance : More than 10kohm*
3	○	○	○	Audio output A (left)	Standard level : 0.5V rms Output impedance : Less than 1kohm*
4	○	○	○	Ground (audio)	
5	○	○	○	Ground (blue)	
6	○	○	○	Audio input A (left)	Standard level : 0.5V rms Output impedance : More than 10kohm*
7	○	●	●	Blue input	0.7 +/- 3dB, 75 ohms positive
8	○	○	○	Function select (AV control)	High state (9.5-12V) : Part mode Low state (0-2V) : TV mode Input impedance : More than 10K ohms Input capacitance : Less than 2nF
9	○	○	○	Ground (green)	
10	○	○	○	Open	
11	○	●	●	Green	Green signal : 0.7 +/- 3dB, 75 ohms, positive
12	○	○	○	Open	
13	○	○	○	Ground (red)	
14	○	○	○	Ground (blanking)	
15	○	-	-	Red input	0.7 +/- 3dB, 75 ohms, positive
	-	○	○	(S signal Chroma input)	0.3 +/- 3dB, 75 ohms, positive
16	○	●	●	Blanking input (Ys signal)	High state (1-3V) Low state (0-0.4V) Input impedance : 75 ohms
17	○	○	○	Ground (video output)	
18	○	○	○	Ground (video input)	
19	○	○	○	Video output	1V +/- 3dB, 75ohms, positive sync 0.3V (-3+10dB)
20	○	-	-	Video input	1V +/- 3dB, 75ohms, positive sync 0.3V (-3+10dB)
	-	○	○	Video input Y (S signal)	1V +/- 3dB, 75ohms, positive sync 0.3V (-3+10dB)
21	○	○	○	Common ground (plug, shield)	

○ Connected ● Not Connected (open) * at 20Hz - 20kHz

Rear Connection Panel



Front Connection Panel



S-Video socket

S Video socket pin configuration		
Pin No	Signal	Signal Level
1	Ground	-
2	Ground	-
3	Y (S signal) input	1V +/- 3dB 75ohm, positive Sync. 0.3V -3 +10dB
4	C (S signal) input	0.3V +/- 3dB 75ohm, positive Sync.

AE-6BA SELF DIAGNOSTIC SOFTWARE

The identification of errors within the AE-6BA chassis is triggered in one of two ways :- 1: Busy or 2: Device failure to respond to IIC. In the event of one of these situations arising the software will first try to release the bus if busy (Failure to do so will report with a continuous flashing LED) and then communicate with each device in turn to establish if a device is faulty. If a device is found to be faulty the relevant device number will be displayed through the LED (Series of flashes which must be counted) See table 1, non fatal errors are reported using this method. Each time the software detects an error it is stored within the NVM. See Table 2.

Table 1

Error Message	LED Code
No error	00
Reserved	01
OCP (Over Current Protection)	02
Over Voltage Protection	03
No Vertical Sync	04
IKR Error at power on	05
IIC bus clock and/or data lines low at power on	06
NVM no IIC bus acknowledge at power on	07
Horizontal Protection	08
Tuner no acknowledge at power on	09
Sound Processor Error	10
Reserved	11
Scanrate Error	12
DAC Error	13
Backend Error	14
Dynamic Convergence Error	15
PIP Error	16

Flash Timing Example : e.g. error number 3

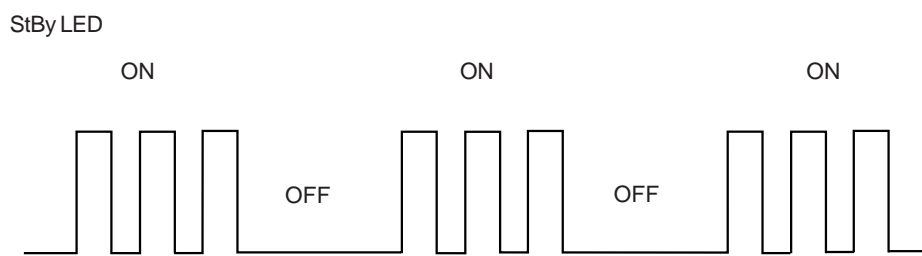

How to enter into Table 2

1. Turn on the main power switch of the TV set.
2. Program Remote Commander for Operation in Service Mode. [See Page 22].
3. Press 'AUX/VIDEO' 'AUX/VIDEO' > 'MENU' on the Remote Commander.
4. Using the Remote Commander, Scroll to the 'Error' item using the down arrow key, then press the right arrow key.
5. The following table will be displayed indicating the error count.

Table 2

Error monitor		
WORKING TIME:	(Hours:Minutes)	82:33
Error counters:		
E02: OCP		0
E03: OVP		0
E04: NO V SYNC		0
E05: IKR		0
E06: IIC		0
E07: NVM		0
E08: H PROT		0
E09: TUNER		0
E10: SOUND		0
E11: 9 VOLTS		0
E12: SCANRATE		0
E13: 3DCOMB		0
E14: BACKEND		0
E15: DYNCON		0
E16: HIGH VOLTAGE		0
E17: AVSWITCH		0
E18: CHROMA DEC		0
E19: FRCA		0
E20: PJ ENG		0
E21: DAC		0
E24: SPEAKER PROT		0
E25: MEMORY STICK		0
Select: ▲ ▼	Previous Menu: ◀	

Note: To clear the error count data press '80' on the Remote commander.

The operating instructions mentioned here are partial abstracts from the 'Operating Instruction Manual'. The page numbers of the 'Operating Instruction Manual' remain as in the manual.

Switching On the TV and Automatically Tuning

1 The first time you switch on your TV, a sequence of menu screens appear on the TV enabling you to: 1) choose the language of the menu screen 2) adjust the picture slant, 3) check how to connect optional equipment to your TV, 4) search and store all available channels (TV Broadcast) and 5) change the order in which the channels (TV Broadcast) appear on the screen. However, if you need to change any of these settings at a later date, you can do so by selecting the appropriate option in the **☰** (Set Up menu) or by pressing the Auto Start Up Button **⏻** on the TV set.

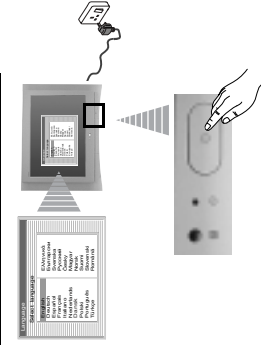

1 Connect the TV plug to the mains socket (220-240V AC, 50Hz). The first time that the TV set is connected, it is usually turned on. If the TV is off, press the **⏻** on/off button on the TV set to turn on the TV. The first time you switch on the TV, a **Language** menu displays automatically on the TV screen.

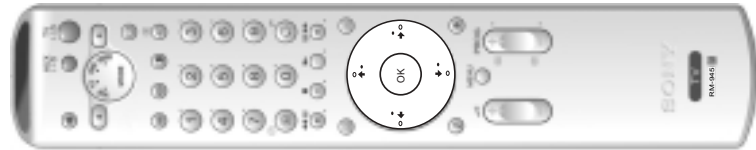

2 Press the **↑**, **↓**, **←** or **→** buttons on the remote control to select your language, then press the **OK** button to confirm your selection. From now on all the menus will appear in your chosen language.

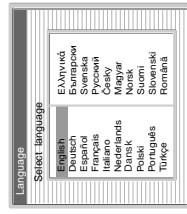

3 Because of the earth's magnetism, the picture might slant. The **Picture Rotation** menu allows you to correct the picture slant if it is necessary.



a) If it is not necessary, press **OK** to select **Not necessary**.
b) If it is necessary, press **←** or **→** to select **Adjust now**, then press **OK** and correct any slant of the picture between **-5** and **+5** by pressing **↑** or **↓**. Finally press **OK** to store.

continued...

4 A diagram will appear showing you how to connect a wide range of equipment to your TV set. Follow the instructions and finally press the **OK** button to remove the diagram and continue the automatic process.

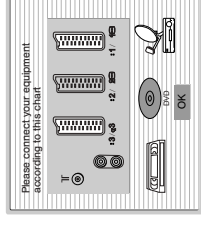

⚠ After the automatic tuning process has finished and any optional equipment has been connected, we recommend you follow the instructions explained on the section "Connection Guide" on page 15 to get the optimum settings related to the optional equipment.

5 The **Auto Tuning** menu appears on the screen. Press the **OK** button to select **Yes**.



6 The TV starts to automatically search and store all available broadcast channels for you.

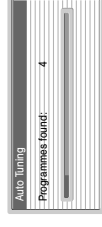

⚠ This procedure could take some minutes. Please be patient and do not press any buttons, otherwise automatic tuning will not be completed.

1 In some countries the TV Broadcaster installs the channels automatically (ACI system). In this case, the TV Broadcaster sends a menu in which you can select your city by pressing the **↑** or **↓** button and **OK** to store the channels.

⚠ If no channels were found during the auto tune process, a message appears automatically on the screen asking you to connect the aerial. Check the aerial connection (refer to page 7). Press the **OK** button to restart the auto tuning process.

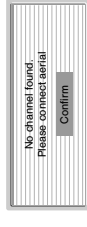

7 After all available channels are captured and stored, the **Programme Sorting** menu automatically appears on the screen enabling you to change the order in which the channels are stored.

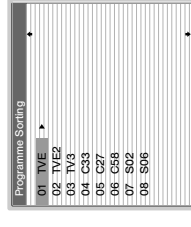

a) If you wish to keep the broadcast channels in the tuned order, go to step 8.

b) If you wish to store the channels in a different order:

- 1 Press the **↑** or **↓** button to select the programme number with the channel (TV Broadcast) you wish to move. Press the **→** button.
- 2 Press the **↑** or **↓** button to select the new programme number position for your selected channel (TV Broadcast). Press the **OK** button to store.
- 3 Repeat steps b)1 and b)2 if you wish to change the order of the other channels.

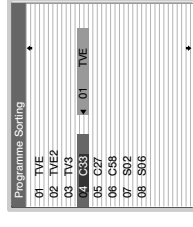

8 Press the **MENU** button to remove the menu from the screen

Your TV is now ready for use

Introducing and Using the Menu System

 Your TV uses an On-Screen menu system to guide you through the operations. Use the following buttons on the Remote Control to operate the menu system:



1 To switch on the menu screens:

Press the **MENU** button to switch the first level menu on.

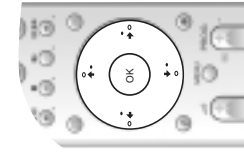
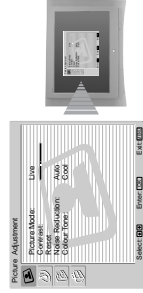

2 To navigate through the menus:

- To highlight and select the desired menu or option, press **↵** or **⬆**.
- To enter the selected menu or option, press **OK** or **⬆**.
- To return to the last menu or option, press **OK** or **⬅**.
- To alter the settings of your selected option, press **↵/⬆/⬅** or **⬆**.
- To confirm and store your selection, press **OK**.



3 To switch off the menu screens:

Press the **MENU** button to remove the menu from the screen.

The Picture Adjustment Menu



 The "Picture Adjustment" menu allows you to alter the picture settings.

To do this:

Press the **MENU** button and then press **OK** to enter this menu. Next press **↵** or **⬆** to select the desired option and press **OK**. Finally read the instructions below on how to operate each option.

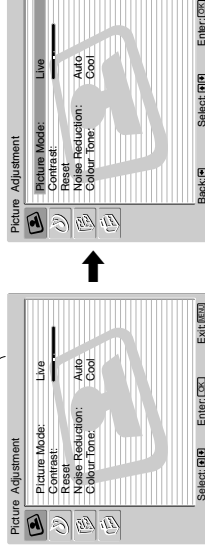

Picture Mode

This option allows you to customise the Picture Mode based on the programme you are watching. After selecting this option press **OK**. Next press **↵** or **⬆** repeatedly to select:

Personal (for individual settings).

Live (for live broadcast programmes, DVD and Digital Set Top Box receivers)

Movie (for films).

Once you have selected your desired option, press **OK** to store.

 "Brightness", "Colour" and "Sharpness" level of "Live" and "Movie" mode are fixed in the factory to get the best picture quality.

Contrast Press **⬅** or **➡** to reduce or enhance picture contrast. Next press **OK** to store.

Brightness Press **⬅** or **➡** to darken or brighten the picture. Next press **OK** to store.

 This option only appears for alteration if "Picture Mode" is set to "Personal".

Colour Press **⬅** or **➡** to decrease or to increase color intensity. Next press **OK** to store.

 This option only appears for alteration if "Picture Mode" is set to "Personal".

Hue Press **⬅** or **➡** to decrease or to increase the green tones. Next press **OK** to store.

 This option only appears for NTSC signal (e.g. USA video tapes).

Sharpness Press **⬅** or **➡** to soften or to sharpen the picture. Next press **OK** to store.

 This option only appears for alteration if "Picture Mode" is set to "Personal".

Reset Press **OK** to reset the picture to the factory preset levels.

Noise Reduction This option is set to **Auto** to automatically reduce the snowy picture that may be visible in the broadcast signal. However, it can be modified by pressing **↵** or **⬆** to select **Off**, **Low**, **Mid** or **High**. Finally press **OK** to store.

Colour Tone This option allows you to alter the tint of the picture. After selecting this option press **↵**. Next press **↵** or **⬆** repeatedly to select: **Warm** (gives the white colours a red tint), **Normal** (gives the white colours a neutral tint), **Cold** (gives the white colours a blue tint). Next press **OK** to store.

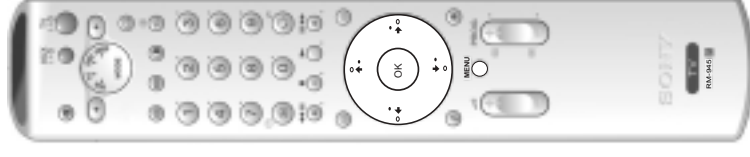

The Sound Adjustment Menu

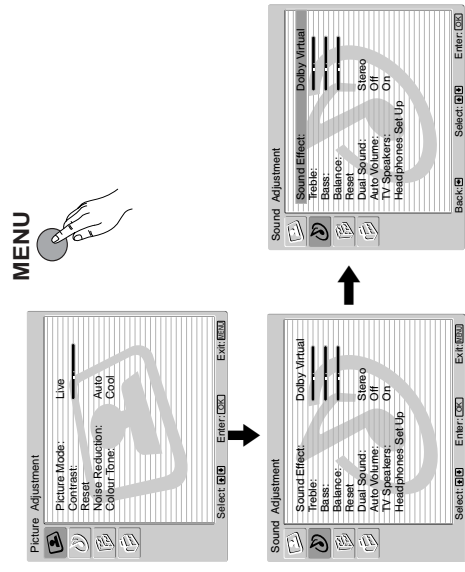

MENU The "Sound Adjustment" menu allows you to alter the sound settings.

To do this:

Press the **MENU** button and press **↓** to select **☺**, then press **OK** to enter this menu. Next press **↓** or **↑** to select the desired option and press **OK**. Finally read the instructions below on how to operate each option.

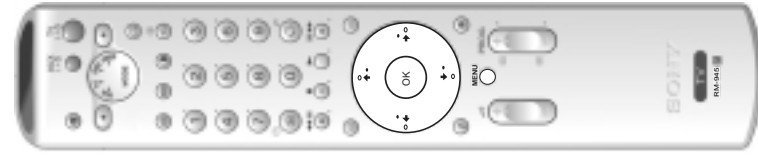

Sound Effect

This option allows you to customise the Sound Effect. After selecting this option press **OK**. Next press **↓** or **↑** repeatedly to select:

- Off** (Flat response).
- Natural** (Enhances clarity, detail and presence of sound by using "BBE High Definition Sound system"*)).
- Dynamic** ("BBE High Definition Sound system"*) intensifies clarity and presence of sound for better intelligibility and musical realism).
- Dolby**** (Dolby Virtual, simulates the sound effect of "Dolby Surround Pro Virtual Logic").

Once you have selected your desired option, press **OK** to store.

Treble

Press **←** or **→** to decrease higher-frequency sounds. Next press **OK** to store.

Bass

Press **←** or **→** to decrease or to increase the lower-frequency sounds. Next press **OK** to store.

Balance

Press **←** or **→** to emphasise the left or the right speaker. Next press **OK** to store.

Reset

Press **OK** to reset the sound to the factory preset levels. Next press **OK** to store.

Dual Sound

- For a Stereo broadcast:
 - Press **↓** or **↑** to select **Stereo** or **Mono**. Next press **OK** to store.
- For a bilingual broadcast:
 - Press **↓** or **↑** to select **Mono** (for mono channel if available), **A** (for channel 1) or **B** (for channel 2). Next press **OK** to store.

PAP (PICTURE AND PICTURE)

i PAP divides the screen into two to watch two pictures in format 4:3 simultaneously.

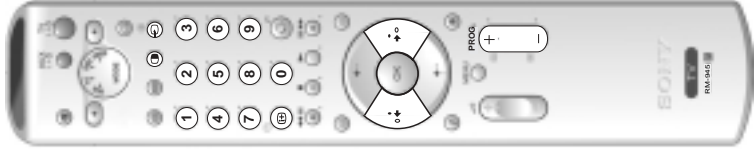

Switching PAP on and off

- 1 Press **☺** to display PAP.
 - i** One of the screens will be framed to indicate that this is the active screen. It means that when you want to select the PAP source, you will be doing it in the active screen.
- 2 Press **☺** again to remove PAP.
 - i** On the screen a banner appears guiding you on how to operate PAP. This banner will disappear after some seconds but it can always be displayed again by pressing the **☺** button.

Changing the active screen

A This is only possible if the Media Selector is set to TV. To change the active screen (framed), press the **←** or **→** buttons.

Selecting PAP source

- 1 **Selecting a TV channel:**
 - Press the **←** button to select the left screen as the active screen. Next press the number buttons or **PROG +/-** to select a TV channel.

A Video input signals can not be displayed on the left screen.

Selecting an input source:

Press the **→** button to select the right screen as the active screen. Next press repeatedly the **☺** button to show the input signal of the connected equipment on right screen of the TV. For more details on which input symbol you wish to choose, please see section "Viewing pictures from equipment connected to the TV" on page 23.

A RF signal (TV broadcast channels) can not be displayed on the right screen.

Selecting the sound

The sound of the active screen (framed) always comes from the TV speakers. Besides that, you can listen to the active screen as well as the non active screen via headphones.

To do this:

With the PAP switched on, refer to the section "The Sound Adjustment Menu", select "Headphones Set Up" and set the option "☺ PAP Sound" according your preference. For details see page 13.

i In PAP (picture and picture) mode, the output from the Scart **☺/☺** 2 is fixed to the right picture.

Teletext

i Teletext is an information service transmitted by most TV stations. The index page of the teletext service (usually page 100) gives you information on how to use the service. To operate teletext, use the remote control buttons as indicated below.

A Teletext errors may occur if you use a channel (TV Broadcast) with a weak signal.

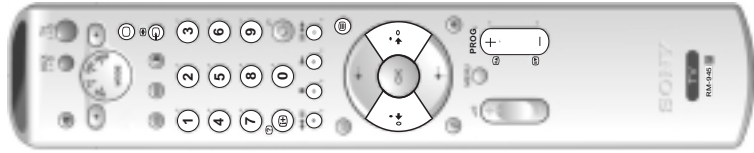

To switch on Teletext :

- 1 Select the broadcast channel which carries the teletext service you wish to view.
- 2 Press the **TEXT** button once to enter Picture and Text (P&T) mode. The screen is divided into two with the Text display on the left and the TV channel in the bottom right corner.
- 3 If you wish to view the Text in full screen mode, press the **TEXT** button a second time.



To select a Teletext page:

Input the 3 digit page number, using the numbered buttons.

- If you make a mistake, retype the correct page number.
- If the counter on the screen continues searching, it is because the page is not available. If this is the case, input another page number.

To access the next or preceding page:

Press **PROG +** (**→**) or **PROG -** (**←**).

To freeze a teletext page:

Press **FREEZE** button. Press again to cancel the freeze.

To reveal concealed information (e.g: answer to a quiz):

Press **INFO/?** button. Press again to conceal the information.

To select a sub page:

A teletext page may consist of several sub pages. In this case, one or more arrows appear next to the page number and an information box is displayed at the bottom of the screen showing the number of sub pages contained on this page. As soon as sub pages are available, they start to automatically appear. If you want to stop the show and select your desired sub page, press **←** or **→** repeatedly.

To Switch Off Teletext:

Press **OFF** button.

Fastext

i Fastext service lets you access Teletext pages with one button push.

When you are in Teletext mode and Fastext is broadcast, a colour coded menu appears at the bottom of the teletext page. Press the appropriate coloured button (red, green, yellow or blue) to access the page corresponding to your menu choice.

Remote Control Configuration for VCR or DVD

i In it's default condition this remote control will operate the basic functions of this Sony TV. Sony DVDs and most Sony VCRs. To control VCRs and DVDs of other manufacturers (and some Sony VCR models), the remote control needs to be configured.

fig. 2



To do this:

- A** Before you start, look up the 3 digit code for your brand of DVD or VCR from the list below. On those brands that have more than one code, enter the first code number.

- Sony will endeavour to update the software according to market changes. Therefore, please refer to the code table included with the remote control for latest code set.

- A small label is added inside the battery door to allow you to record your brand codes.

- 1 Press and hold the **←** button of the remote control for approximately 6 seconds until the green DVD and VCR light of the Media Selector starts flashing (see fig. 1).

fig. 1

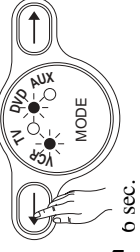

- 2 While the VCR and DVD lights are flashing, enter all three digits of code for your brand of VCR or DVD (see the list below) using the **num** buttons on the remote control (see fig. 2).

fig. 3

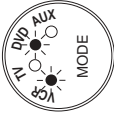

- i** If your selected code is entered correctly, the VCR or DVD green light (according to your selection) will be lit momentarily (see fig. 3) otherwise repeat all the above steps.

- 3 Turn on your VCR or DVD and check that the main functions work.

- A** If your device is not working or some of the functions do not work please check that you entered the correct code set or try the next code listed against the brand.

- Not all brands are covered and not all models of every brand may be covered.

- 4 Always remember to press the **←** or **→** button until the green light illuminates according to the equipment you want to operate with this remote control: **VCR, TV or DVD**.

VCR Brand List



Brand	Code	Brand	Code
SONY (VHS)	301, 302, 303, 308, 309, 362	SONY	001, 029, 030, 036, 037, 038, 039, 040, 041, 042, 043, 044, 053, 054, 055
SONY (BETA)	303, 307, 310	AIWA	021
SONY (DV)	304, 305, 306	AKAI	032
AIWA	325, 331, 351	DENON	018, 027, 020, 002
AKAI	326, 329, 330	GRUNDIG	009, 028, 023, 024, 016, 003
DAEWOO	342, 343	HITACHI	025, 026, 015, 004, 035
GRUNDIG	358, 355, 360, 361, 320, 351, 366	JVC	006, 017
HITACHI	327, 333, 334	KENWOOD	008
JVC	314, 315, 322, 344, 352, 353, 354, 348, 349	LG	015, 014, 034
LG	332, 338	LOEWE	009, 028, 023, 024, 016, 003
LOEWE	358, 355, 360, 361, 320, 351	MATSUI	013, 016
MATSUI	356, 357	ORION	022, 033
ORION	328	PANASONIC	018, 027, 020, 002, 045, 046, 047
PANASONIC	321, 323	PHILIPS	009, 028, 023, 024, 016, 003, 031
PHILIPS	311, 312, 313, 316, 317, 318, 358, 359, 363, 364	PIONEER	004, 050, 051, 052
SAMSUNG	339, 340, 341, 345	SAMSUNG	011, 014
SANYO	335, 336	SANYO	007
SHARP	324	SHARP	019, 027
THOMSON	319, 350, 365	THOMSON	012
TOSHIBA	337	TOSHIBA	003, 048, 049
		YAMAHA	018, 027, 020, 002

DVD Brand List

Technical Specifications

- TV system:**
I
- Colour system:**
PAL
SECAM, NTSC 3.58, 4.43 (only Video In)
- Channel Coverage:**
UHF: B21-B69
- Picture Tube:**
Flat Display FD Trinitron WIDE:
KV-28FQ86U: 28" (approx. 71cm, measured diagonally)
KV-32FQ86U: 32" (approx. 82cm, measured diagonally)

Rear Terminals

- AV1  1
21-pin scart connector (CENELEC standard) including audio/video input, RGB input, TV audio/video output.
- AV2  2
21-pin Scart connector (CENELEC standard) including audio/video input, RGB input, monitor audio/video output.
- AV3  3
21-pin Scart connector (CENELEC standard) including audio/video input, S video input, selectable audio/video output and SmartLink interface.

Sound Output:

- 2 x 20 W (music power)
 - 2 x 10 W (RMS)
- Woofer:**
30 W (music power)
15 W (RMS)

Power Consumption:

- KV-28FQ86U: 130 W
- KV-32FQ86U: 130 W

Standby Power Consumption:

- 0.5 W

Dimensions (w x h x d) :

- KV-28FQ86U:
approx. 789 x 533 x 510 mm.
- KV-32FQ86U:
approx. 910 x 586 x 586 mm.

Weight:

- KV-28FQ86U: approx. 45 Kg.
- KV-32FQ86U: approx. 64 Kg.





Accessories supplied:

- 1 Remote Control (RM-945)
- 2 Batteries (IEC designated, AA size)

Other features:

- 100 Hz picture, Digital Plus.
- Teletext, Fastext, TOPtext.
- NexTView.
- SmartLink.
- TV system autodetection.
- Dolby Virtual.
- BBE Digital.
- NICAM.
- PAP.
- ACI (Auto Channel Installation).

Front Terminals

-  4 S Video input – 4 pin DIN.
-  4 video input – phono jack.
-  4 audio input – phono jacks.
-  headphones jack.

Optional accessories:

- Stand especially designed for this TV
KV-28FQ86U: SU-28FQ3.
KV-32FQ86U: SU-32FQ3.

Lifting the TV Set

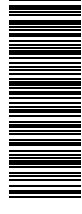

206779201

2-067-792-01

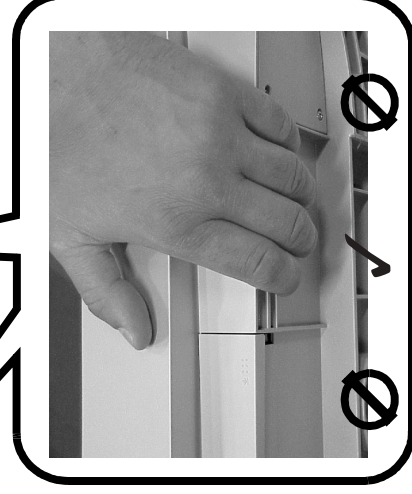
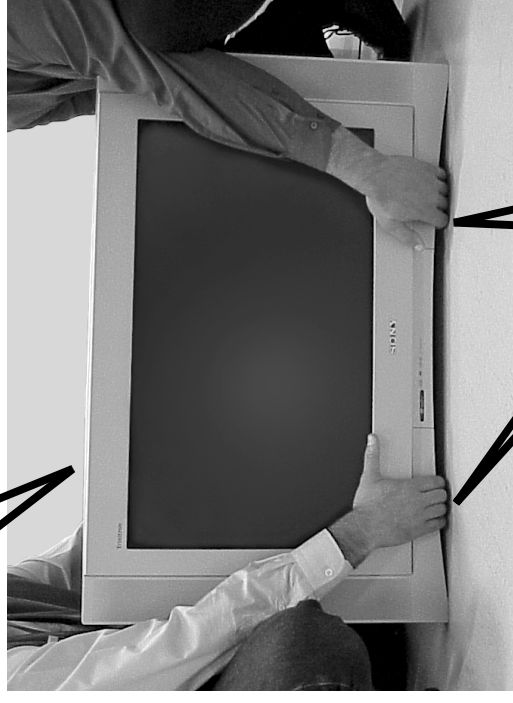
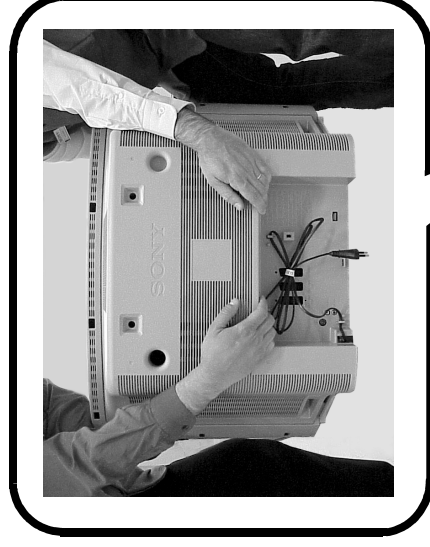





Design and specifications are subject to change without notice.





Troubleshooting

 Here are some simple solutions to problems which may affect the picture and sound.



Problem	Solution
No picture (screen is dark) and no sound.	<ul style="list-style-type: none"> • Check the aerial connection. • Plug the TV in and press the  button on the front of the TV. • If the standby indicator  is on, press TV I/O button on the remote control.
Poor or no picture (screen is dark), but good sound.	<ul style="list-style-type: none"> • Using the menu system, select the "Picture Adjustment" menu and select "Reset" to return to the factory settings (see page 11).
No picture or no menu information from equipment connected to the Scart connector.	<ul style="list-style-type: none"> • Check that the optional equipment is on and press the  button repeatedly on the remote control until the correct input symbol is displayed on the screen (see page 23).
Good picture, no sound.	<p>Press the  + button on the remote control.</p> <p>Check that "TV Speakers" is "On" in the "Sound Adjustment" menu (see page 13).</p> <p>Check that headphones are not connected.</p>
No colour on colour programmes.	<ul style="list-style-type: none"> • Using the menu system, select the "Picture Adjustment" menu and select "Reset" to return to factory settings (see page 11).
When you switch on the TV the last channel you were watching before switching the TV off does not appear.	<ul style="list-style-type: none"> • This is not a malfunction. Press the number buttons on the remote control to select the desired channel.
Distorted picture when changing programmes or selecting teletext.	<ul style="list-style-type: none"> • Turn off any equipment connected to the Scart connector on the rear of the TV.
Wrong characters appear when viewing NextView.	<ul style="list-style-type: none"> • Use the menu system to enter the "Language" menu (see page 16) and select the same language that NextView is broadcast in.
Picture slanted.	<ul style="list-style-type: none"> • Using the menu system, select the "Picture Rotation" option in the "Features" menu to correct the picture slant (see page 15).
Snowy picture when viewing a TV channel.	<ul style="list-style-type: none"> • Using the menu system, select the "Manual Programme Preset" menu and adjust Fine Tuning (AFT) to obtain better picture reception (see page 18). • Using the menu system, select the "Noise Reduction" option in the "Picture Adjustment" menu and select "Auto" to reduce the noise in the picture (see page 11).

continued...

Problem

No unscrambled picture whilst viewing an unscrambled channel with a decoder or a Set Top Box connected through the Scart connector  3/  2.

Solution

- Using the menu system, select the "Features" menu and set "AV3 Output" to "TV" (see page 15).
- Check that the Decoder or the Set Top Box is not connected on the scart  2/  2.

, ,  and  buttons do not work in PAP mode.

- PAP navigation is only possible in TV mode, please check that Media Selector is set to TV.

Remote control does not function.

- Check that the Media Selector on the remote control is set to the device you are using (VCR, TV or DVD).
- If the remote control does not operate the VCR or DVD even when the Media Selector has been set correctly, enter the necessary code set as explained on page 24.
- Replace the batteries.

GB

The standby indicator  on the TV flashes.

- Contact your nearest Sony service centre.



- **If you continue to experience problems, have your TV serviced by qualified personnel.**
- **Never open the casing yourself.**

SECTION 2 DISASSEMBLY

2-1. Rear Cover Removal



Remove the rear cover fixing screws indicated and pull the rear cover backwards away from the set. Take care when removing the rear cover not to damage the speaker cable [Disconnect the speaker connector] a speaker is fitted inside the rear cover.

2-2. Speaker Connector Disconnection



Before completely removing the rear cover disconnect the speaker connector which is located on the inside of the set.

2-3. Chassis Removal and Refitting

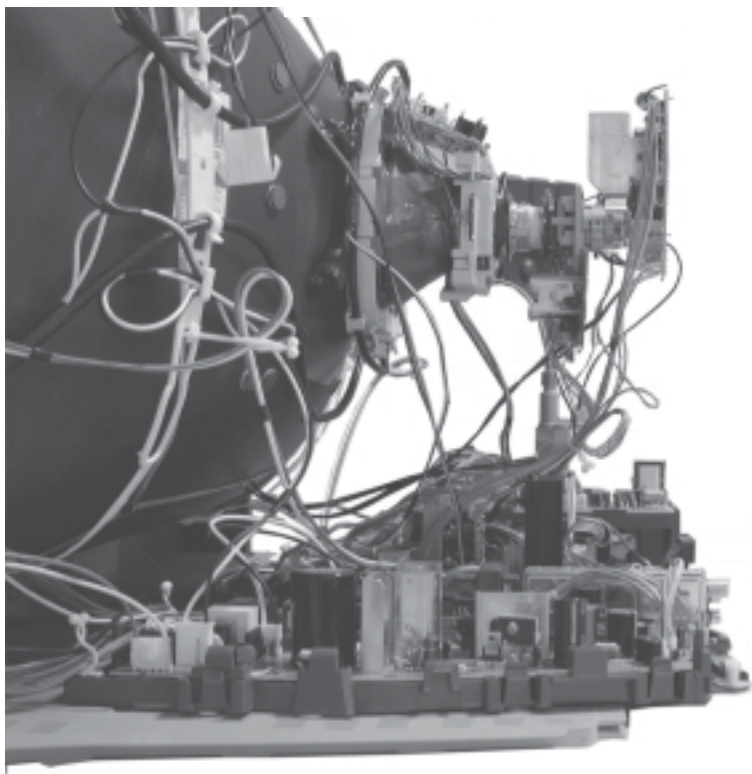

To remove lift the main bracket rear slightly and slide the chassis away from the bezel. Ensure that the interconnecting leads are released from their purse locks to prevent damage being caused.



When refitting the chassis ensure that the main bracket is located in the bezel guide slots before sliding the chassis forwards. Refit the inter-connecting leads in their respective purse locks.

2-4. Service Position

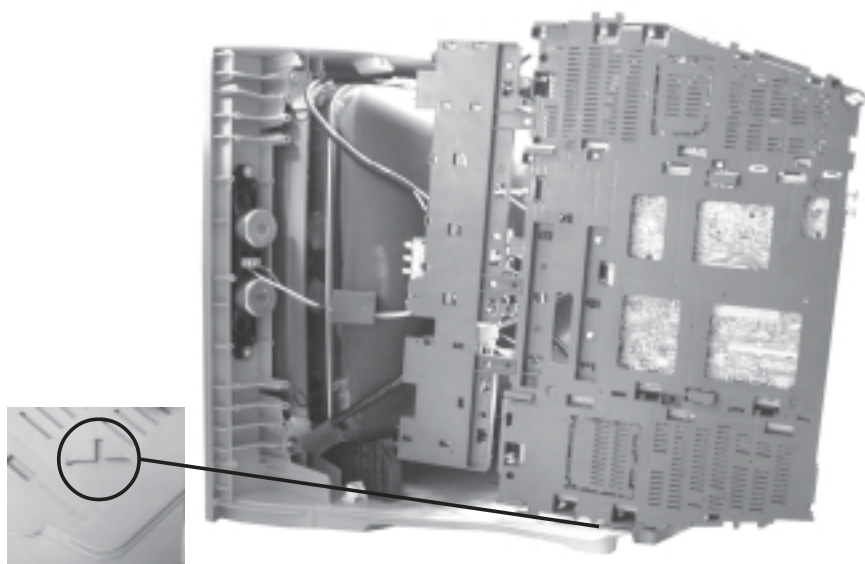

To place the chassis in the service position, insert the main bracket firmly into the T-slot located on the left corner of the bezel as indicated (see inset). To gain access to the underside of the boards follow the instructions on page 17. [Removal and Replacement of the main bracket bottom plates].

2-5. G Board Removal

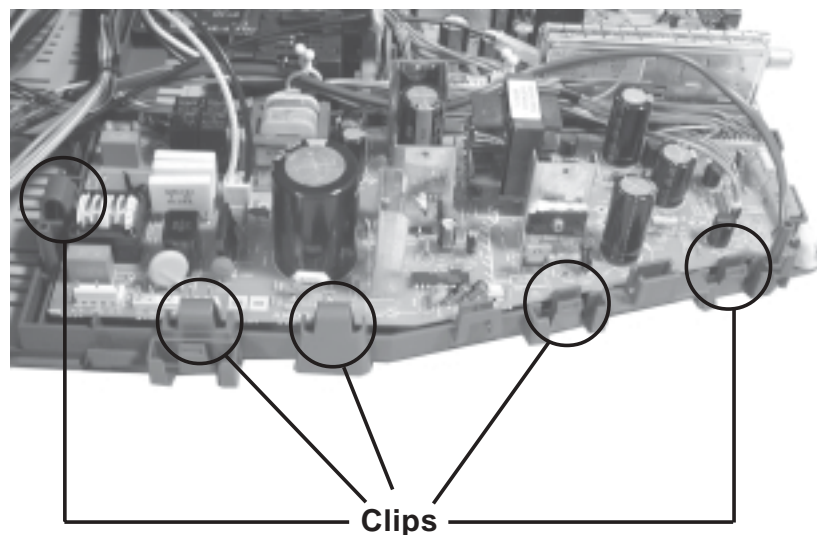

To remove the G Board remove the two screws from the middle of the board, release the clips circled and ease the board gently away from the support bracket.

2-6. D2 Board Removal

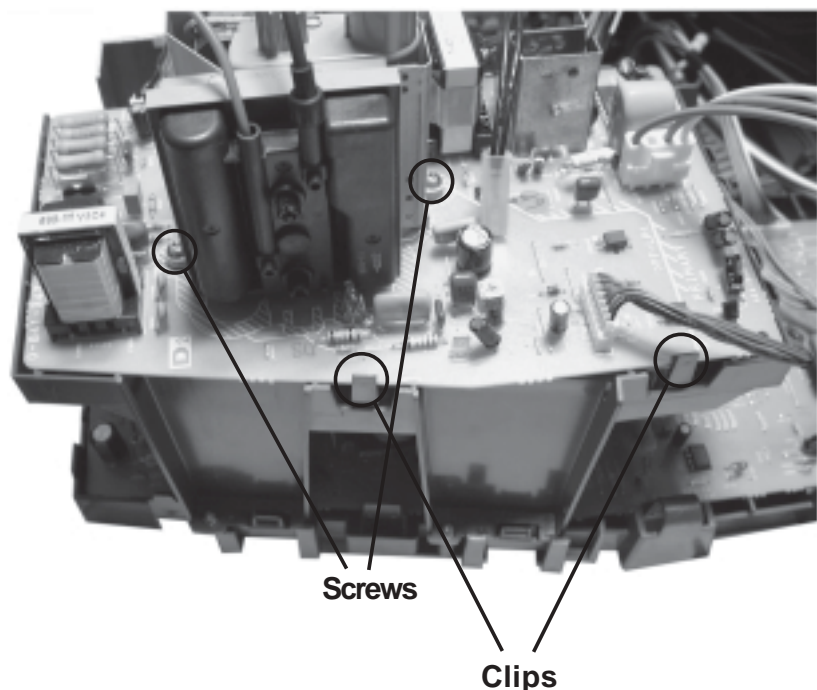

To remove the D2 board remove the two screws circled, release the clips circled and ease the board gently away from the support bracket.

2-7. D Board Removal

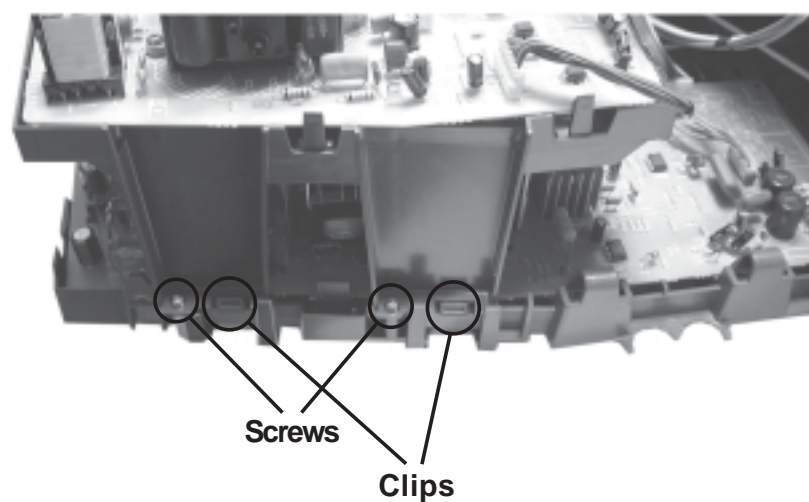

To remove the D board first remove the D2 bracket by removing the two screws circled and releasing the four clips (two on each side of the bracket). The D board can then be removed using the same method as the G board but with the necessity to remove only one screw from the middle of the D board.

2-8. Picture Tube Removal

WARNING: BEFORE REMOVING THE ANODE CAP

High voltage remains in the CRT even after the power is disconnected. To avoid electric shock, discharge CRT **before** attempting to remove the anode cap. Short between anode and CRT coated earth ground strap.

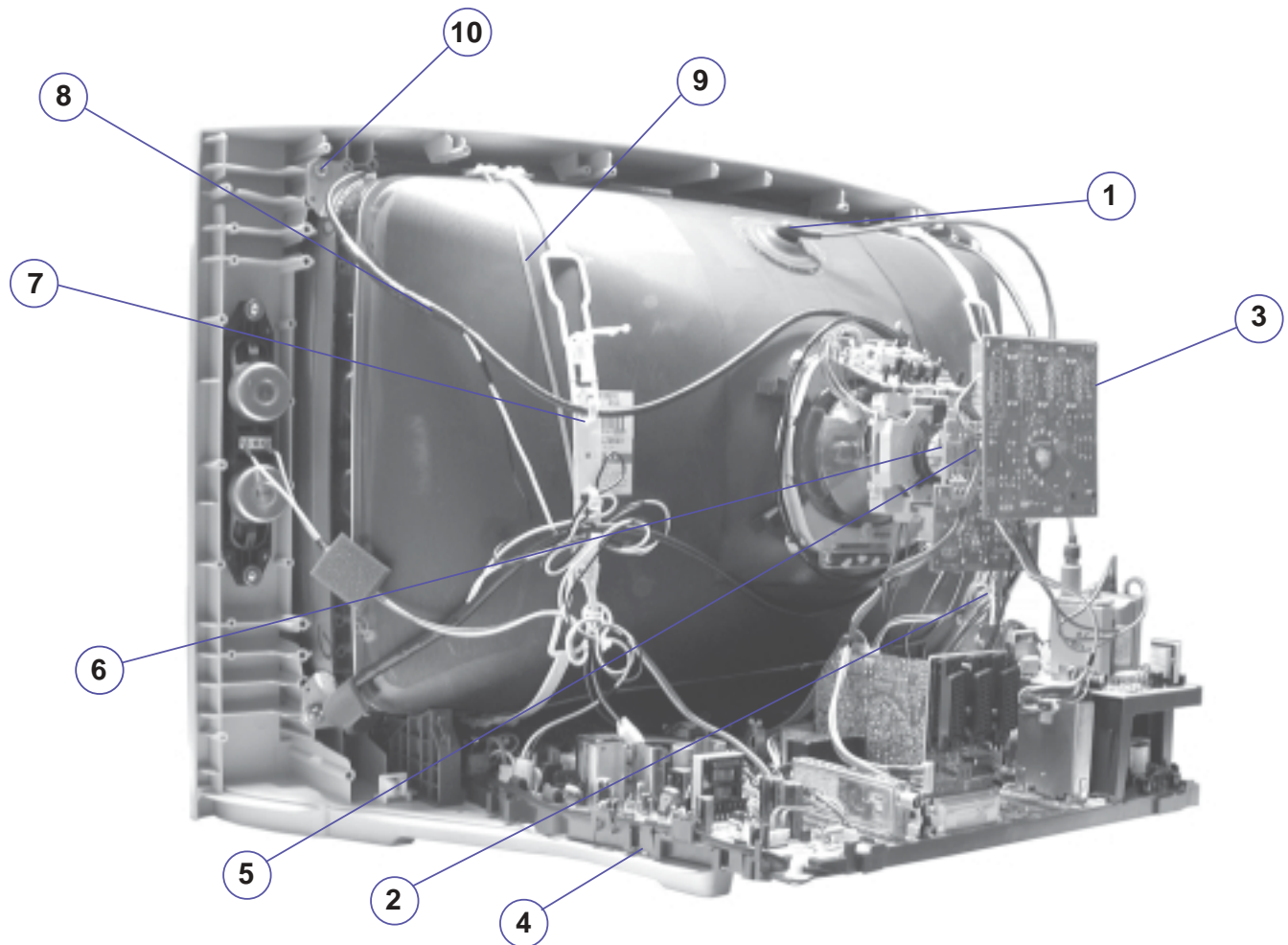
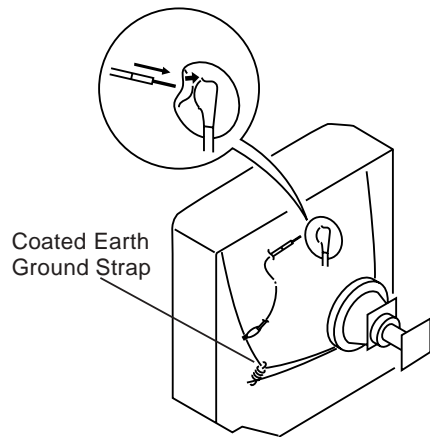

1. Discharge the anode of the CRT and remove the anode cap.
2. Unplug all interconnecting leads from the Deflection yoke, neck assy, degaussing coils and CRT grounding strap.
3. Remove the C Board from the CRT.
4. Remove the chassis assembly.
5. Loosen the Neck assembly fixing screw and remove.
6. Loosen the Deflection yoke fixing screw and remove.
7. Place the set with the CRT face down on a cushion and remove the Degaussing Coil holders.
8. Remove the Degaussing Coils.
9. Remove the CRT grounding strap and spring tensioners.
10. Unscrew the four CRT fixing screws [located on each CRT corner] and remove the CRT.
[Take care not to handle the CRT by the neck.]

Removal of the Anode-Cap

REMOVAL PROCEDURE.

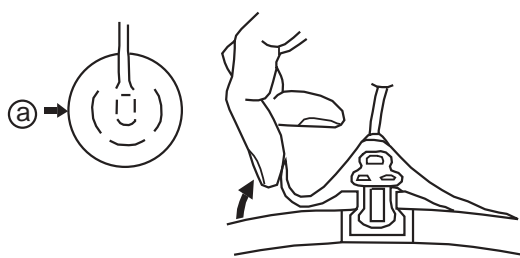

- ① Turn up one side of the rubber cap in the direction indicated by the arrow (a)

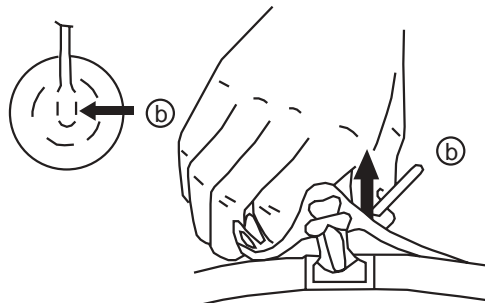

- ② Using a thumb pull up the rubber cap firmly in the direction indicated by the arrow (b)

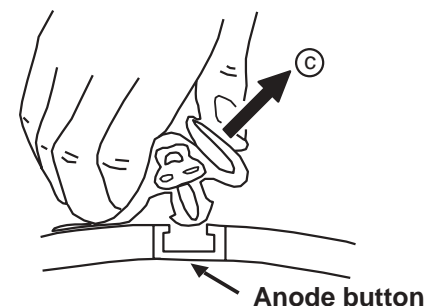

- ③ When one side of the rubber cap is separated from the anode button, the anode-cap can be removed by turning up the rubber cap and pulling it up in the direction of the arrow (c)

How to handle the Anode-Cap

1. To prevent damaging the surface of the anode-cap do not use sharp materials.
2. Do not apply too great a pressure on the rubber, as this may cause damage to the anode connector.
3. A metal fitting called a shatter hook terminal is fitted inside the rubber cap.
4. Do not turn the rubber foot over excessively, this may cause damage if the shatter hook sticks out.

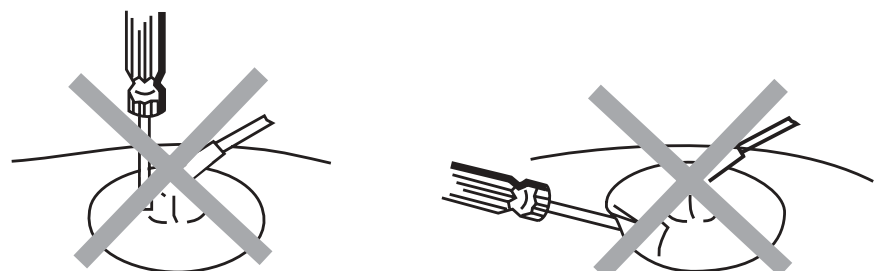

REMOVAL AND REPLACEMENT OF THE MAIN-BRACKET BOTTOM PLATES.

(1) REMOVING THE PLATES

In the event of servicing being required to the solder side of the printed wiring boards, the bottom plates fitted to the main chassis bracket require to be removed. This is performed by cutting the gates with a sharp wire cutter at the locations indicated by the arrows.

Note : There are 2 plates fitted to the main bracket. Only remove the necessary plate to gain access to the printed wiring board.

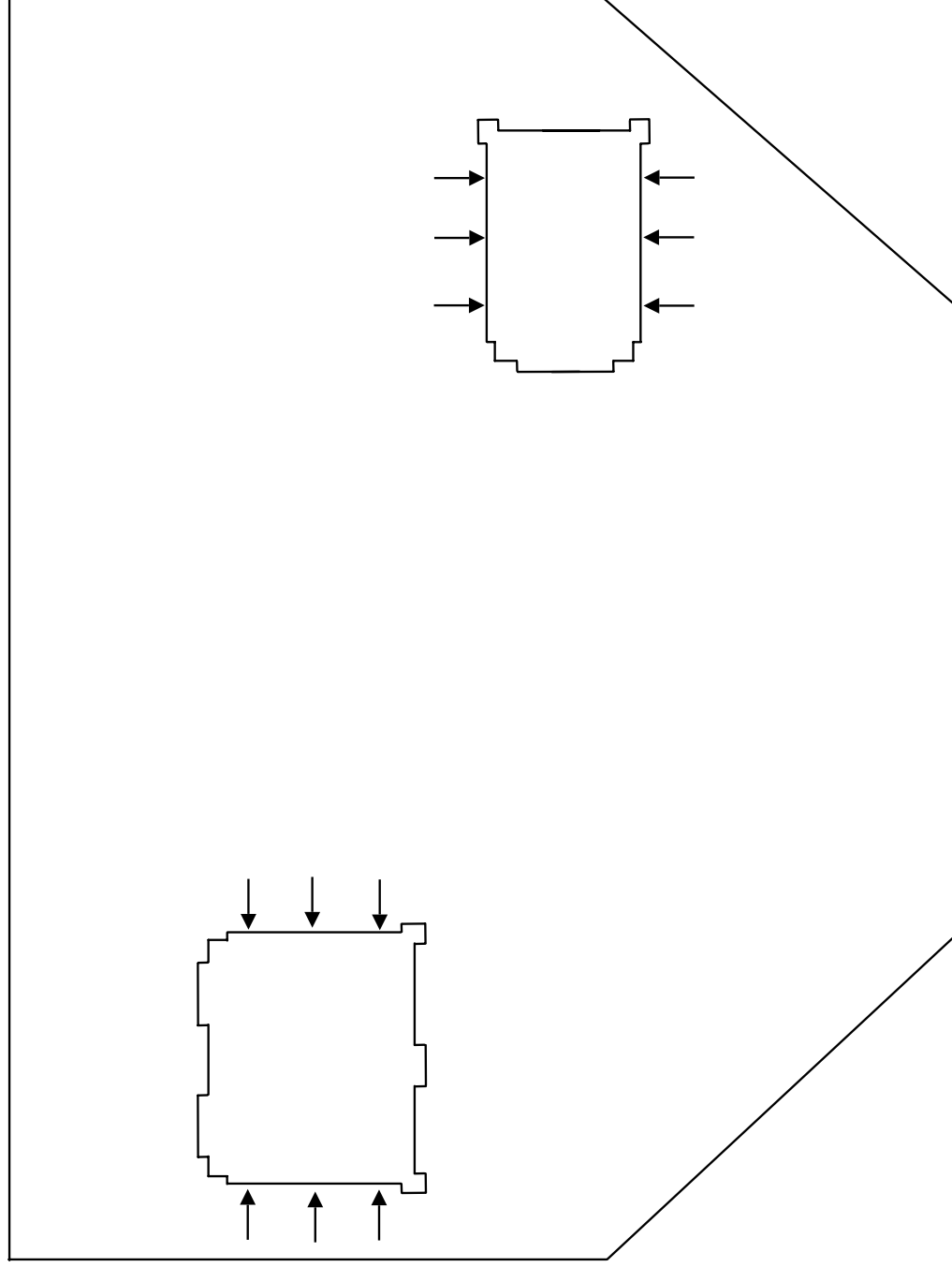

For safety reasons, on no account should the plates be removed and not refitted after servicing.

(2) REFITTING THE PLATES

Because the plates differ in size it is important that the correct plates are refitted in their original location.

Please note that the plates need to be rotated 180 degrees from their cut position to allow the tabs to be fitted into their catch positions.

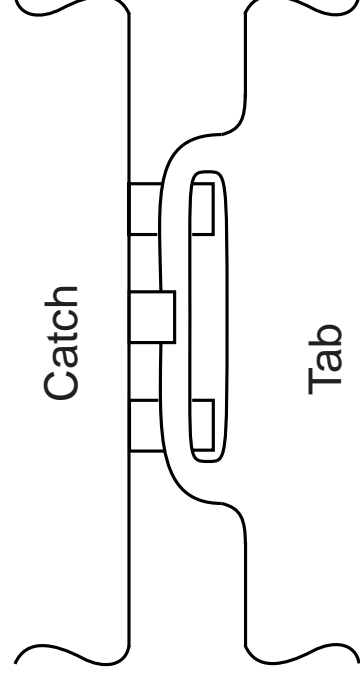

SECTION 3 SET-UP ADJUSTMENTS

- When complete readjustment is necessary or a new picture tube is installed, carry out the following adjustments.
- Unless there are specific instructions to the contrary, carry out these adjustments with the rated power supply.
- Unless there are specific instructions to the contrary, set the controls and switches to the following settings :

Contrast normal

Brightness normal

Carry out the adjustments in the following order :

- 3-1. Beam Landing.
- 3-2. Convergence.
- 3-3. Focus.
- 3-4. White Balance.

Note : Test equipment required.

1. Color bar/pattern generator.
2. Degausser.
3. Oscilloscope.
4. Digital multimeter.

3-1. Beam Landing

Preparation :

1. In order to reduce the influence of geomagnetism on the set's picture tube, face it in an easterly or westerly direction.
2. Switch on the TV set's power and degauss with a degausser.

(1) Adjustment of Correction Magnet for Y-Splitting Axis.

1. Input a crosshatch signal from the pattern generator.
2. Set the Picture control to minimum and confirm that the Brightness control is set to normal.
3. Position the neck assembly as indicated in Fig.3-2.
4. Loosen the deflection yoke fixing screw.
5. Move the deflection yoke as far forward as is possible.
6. Adjust the upper and lower pin symmetrically by opening or closing the Y-splitting axis correction magnets located on the neck assembly. [See Fig 3-3]
7. Return the deflection yoke to its original position and re-tighten its fixing screw.

Fig.3-1

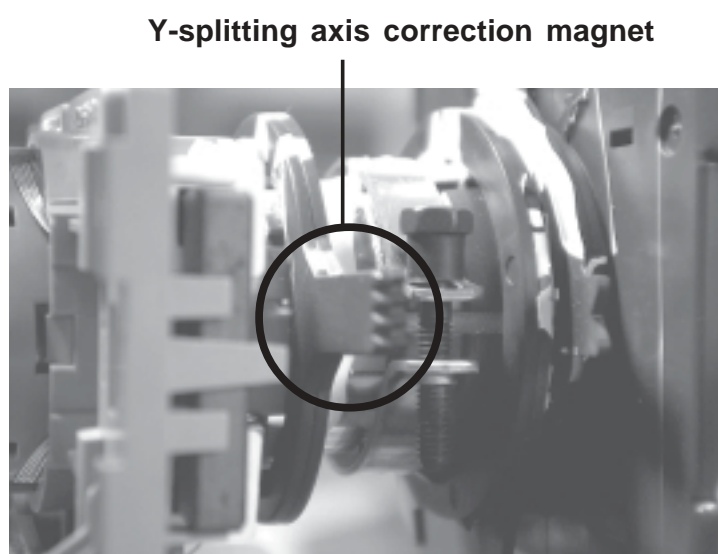

Caution :

High voltages are present on the Deflection yoke terminals - take care when handling the Deflection yoke whilst carrying out adjustments.

(2) Landing

Note : Before carrying out the following adjustments adjust the magnets as indicated [See Fig.3-4].

1. Input a crosshatch signal from the signal generator.
2. Rough-adjust the focus and horizontal convergence.
3. Switch from the crosshatch pattern to an all-red pattern.
4. Move the deflection yoke backwards and adjust with the purity magnet so that the red is at the centre and it aligns symmetrically [See Fig.3-5].
5. Move the deflection yoke forward to the point where the entire screen just becomes red [Mark its position].
6. Move the deflection yoke further forward until the screen just changes colour at the edges. [Mark its position]
7. Position the deflection yoke between the two marks indicated above.
8. Input a crosshatch pattern from the pattern generator and rotate the deflection yoke so that the horizontal lines are parallel with the top and bottom of the screen.
9. When the position of the deflection yoke has been determined, fasten it with its fixing screw.
10. Switch the pattern generator to green then blue and confirm the purity.
11. If the beam does not land correctly in all the corners of the screen, use disk magnets to correct it. [Confirm the corner landing for green and blue]

Fig.3-2

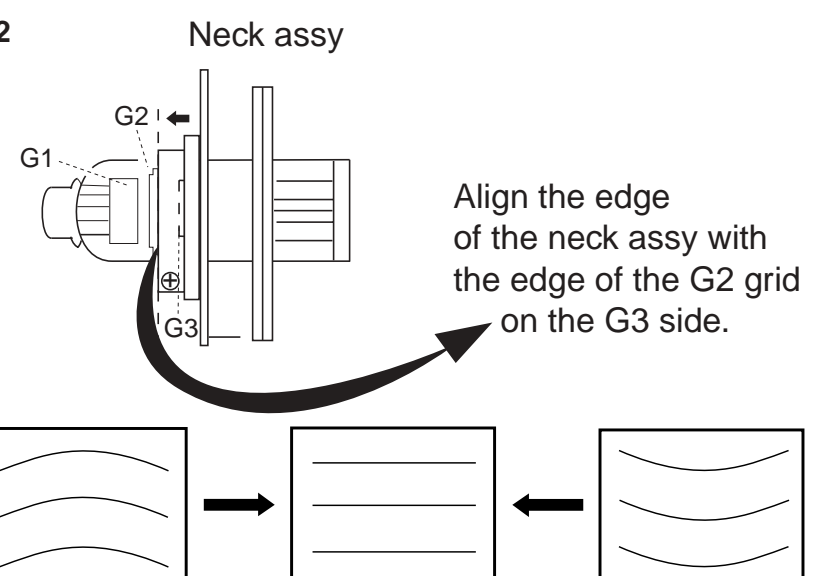
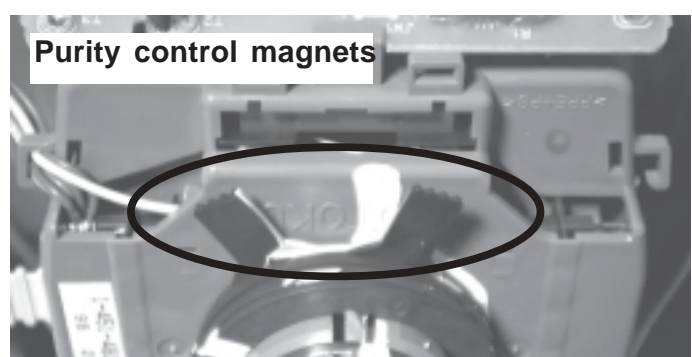
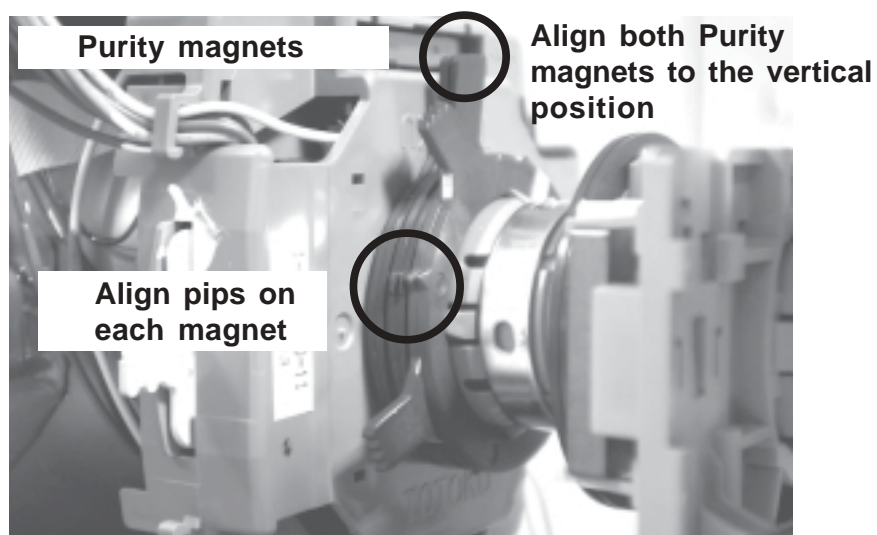

Fig.3-3

Fig.3-4



3-2. Convergence

(1) Screen centre convergence [Static convergence]

1. Input a dot pattern signal from the pattern generator.
2. Normalize the picture setting.
3. [Moving vertically], adjust the V.STAT magnet so that the vertical red, green and blue dots coincide at the centre of the screen.

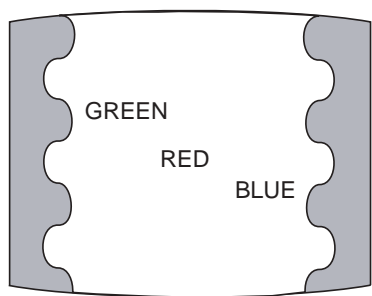
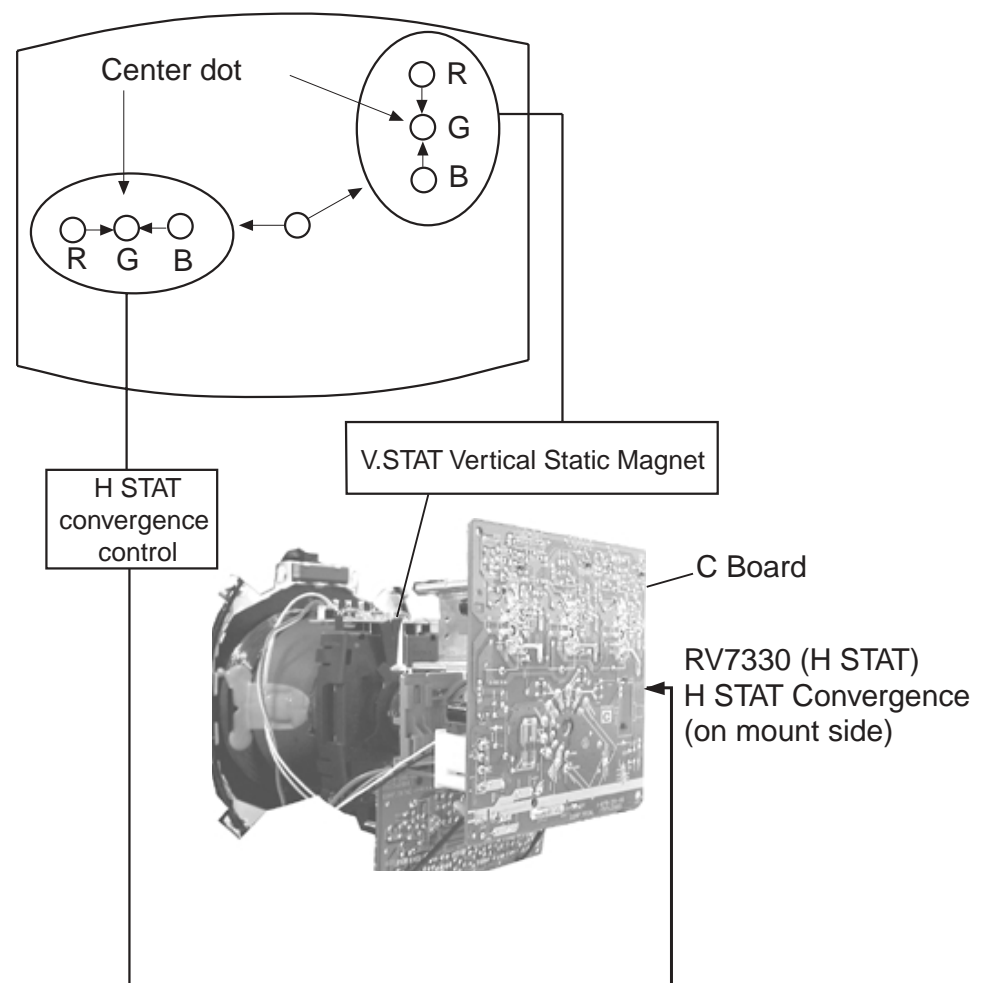
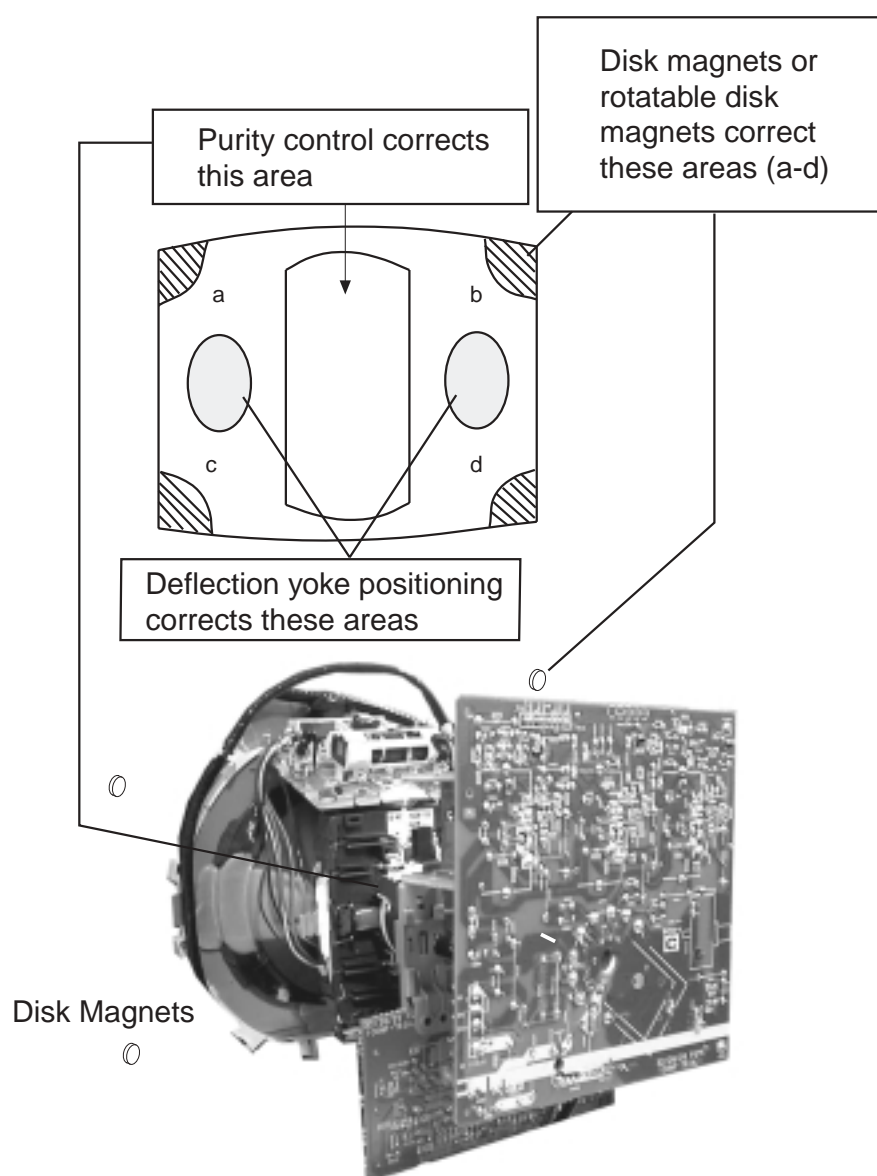
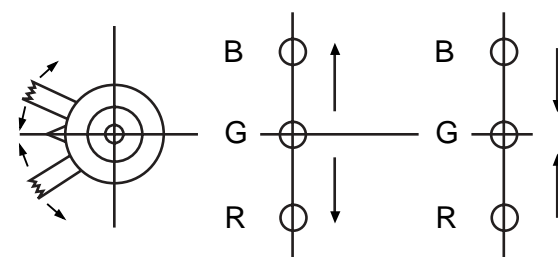

Fig.3-5



By opening or closing the V.STAT magnet, the red green and blue dots move in the direction indicated below.



Note: Do not adjust the H.STAT by rotating the V.STAT magnets as this can affect the focus setting.

4. Correction for HMC [Horizontal mis-convergence] and VMC [Vertical mis-convergence] by using the BMC [Hexapole] magnet.

a). HMC correction by BMC [Hexapole] magnet and movement of the electron beam.

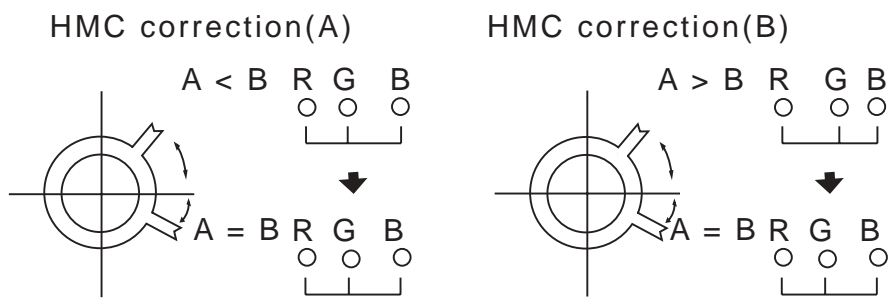

b). VMC correction by BMC [Hexapole] magnet and movement of the electron beam.

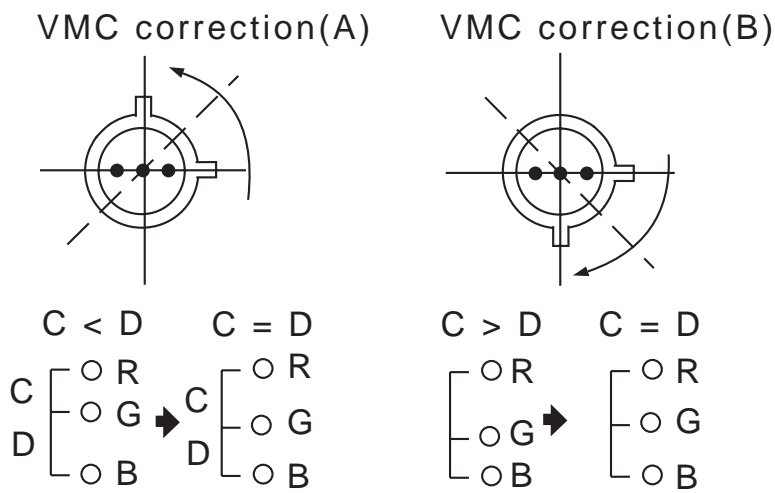

HAMP Adjustment

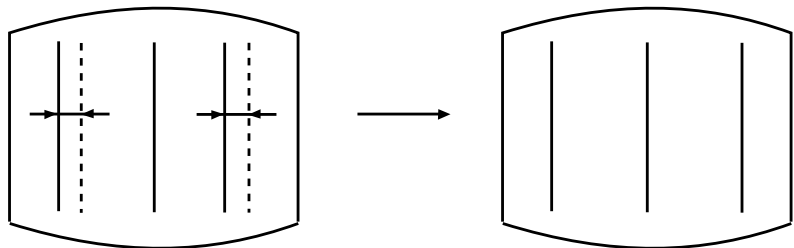

Adjust the HAMP using HAMPL and HAMPR registers in the Dynamic Convergence section of the service menu.

HTIL Adjustment

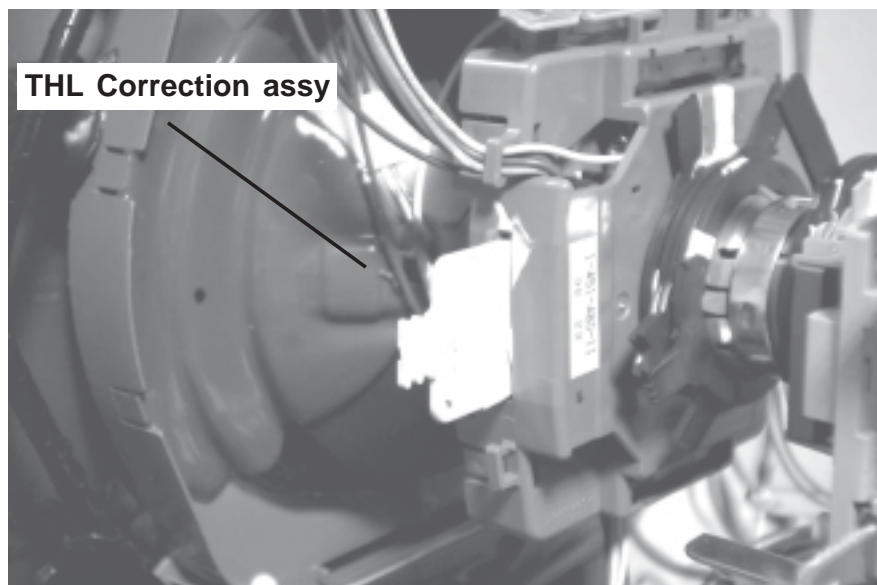

HTIL correction can be performed by adding a THL correction assembly to the Deflection yoke.

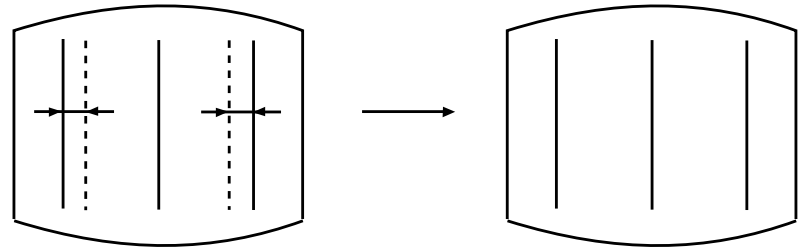

YCH Adjustment

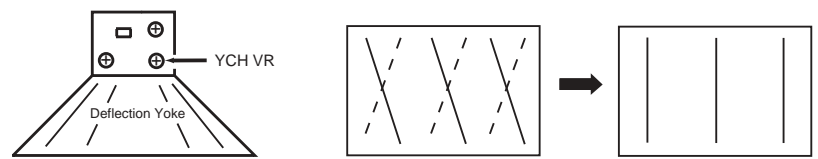

TLV Adjustment

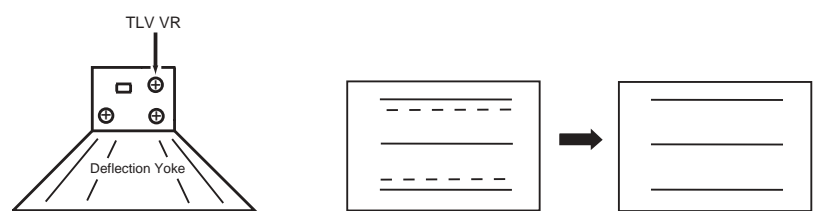

H-TRAP Adjustment

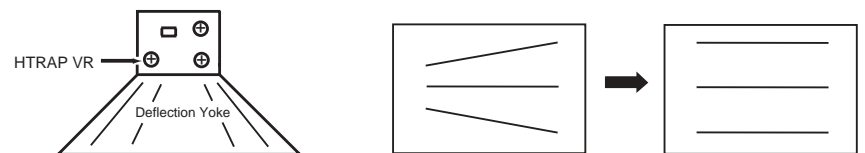

The H-TRAP should not be adjusted unless absolutely necessary as it affects the TLV settings.

Layout of each control

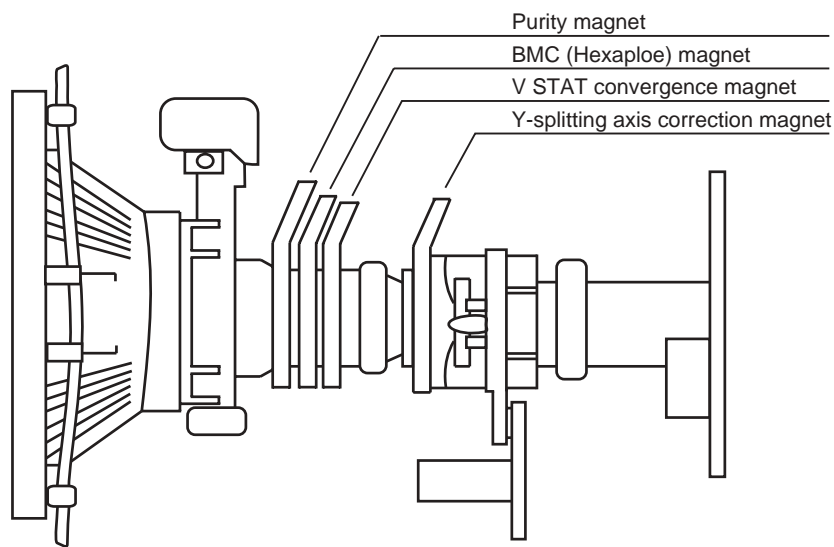

Note : If you are unable to adjust the corner convergence properly, this can be corrected with the use of permalloy magnets.

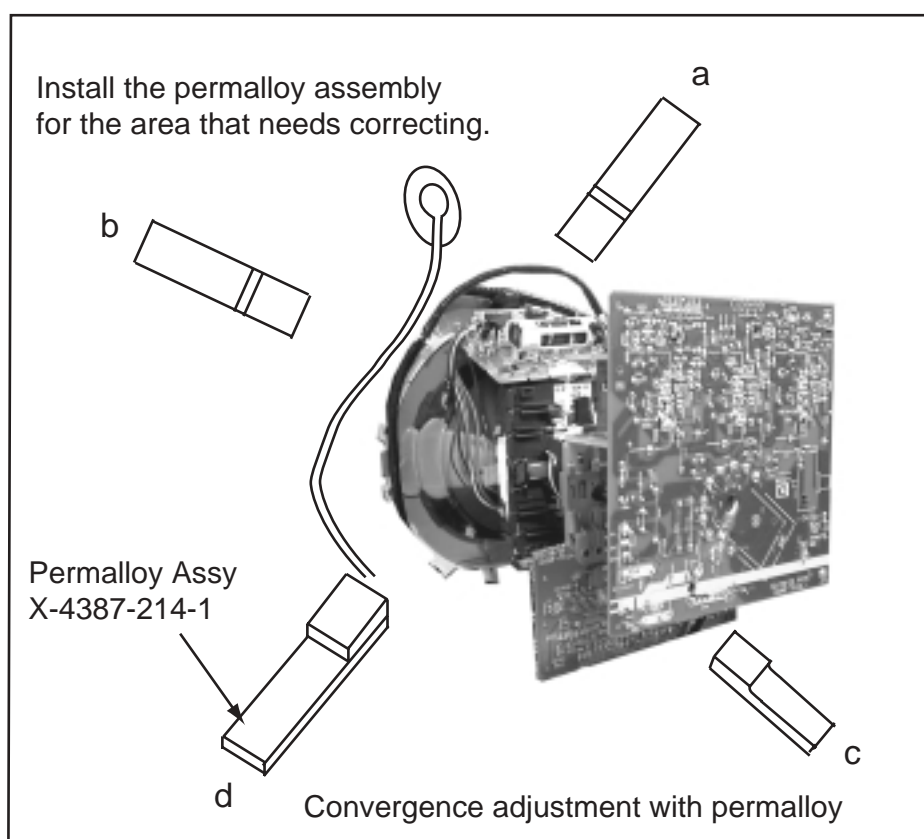
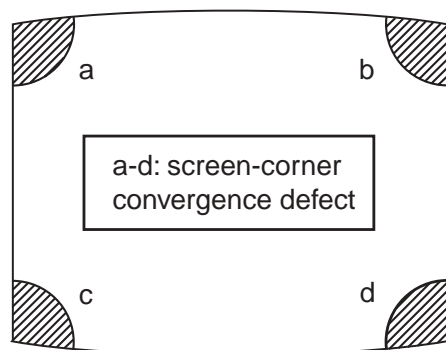

3-3. Focus Adjustment

1. Receive a television broadcast signal.
2. Normalize the picture setting.
3. Adjust the focus control located on the flyback transformer to obtain the best focus at the centre of the screen. Bring only the centre area of the screen into focus, the magenta appears on the screen. In this case, adjust the focus to optimize the screen uniformly.

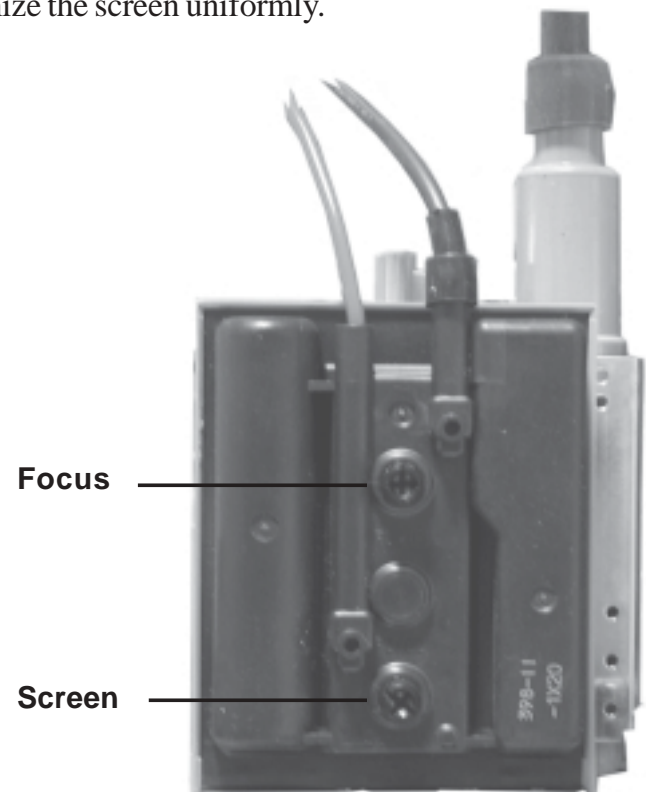

3-4. Screen (G2), White Balance

[Adjustment in the service mode using the remote commander]

G2 adjustment

1. Input a dot signal from the pattern generator.
2. Set the Picture, Brightness and Colour to minimum.
3. Apply 175V DC from an external power supply to the R, G and B cathodes of the CRT.
4. Whilst watching the picture, adjust the G2 control [SCREEN] located on the flyback transformer to the point just before the flyback return lines disappear.

White balance adjustment for TV mode

1. Input an all-white signal from the pattern generator.
2. Program the Remote Commander for operation in Service Mode. [See Page 22].
3. Enter into the 'Service Mode' by pressing 'AUX/VIDEO' button twice and 'MENU' on the Service Commander.
4. Select 'Service' from the on screen menu display and press 'Right Arrow'.
5. The 'Service' menu will appear on the screen.[See Page 22]
6. Select 'Picture' from the on screen menu and press right arrow.
7. Select 'Picture settings' from the on screen menu and press right arrow and set the 'Contrast_Max' to MAX.
8. Select 'White Balance' from the on screen menu and press right arrow.
9. The 'White Balance' menu will appear on the screen.
10. Set the 'Normal_PAL_RD' to 465.
11. Adjust the 'Normal_PAL_GD' and the 'Normal_PAL_BD' so that the white balance becomes optimum.
12. Select 'Picture settings' from the on screen menu and press right arrow and set the 'Contrast_Min' to MIN.
13. Set the 'Normal_PAL_RC' to 121.
14. Adjust the 'Normal_PAL_GC' and the 'Normal_PAL_BC' with the left and right buttons on the commander so that the white balance becomes optimum.
15. Press the 'OK' button to write the data for each item.

SECTION 4 CIRCUIT ADJUSTMENTS

4-1. Electrical Adjustments

Service adjustments to this model can be performed using the supplied remote Commander RM-945.

Programming the Remote Commander for Operation in Service Mode

1. Press and hold the left Mode Select button until the VCR and DVD LED's flash.
2. Press 99999. The TV LED should light. The remote commander is now set to Service Mode.
3. To return the remote commander to normal operation mode repeat step 1. then press 00000. The TV LED should light. The remote commander is now set to normal mode.



Setting the TV into Service Mode

1. Program the remote commander for operation in Service Mode as described above.
2. Turn on the TV main power switch.
3. Press the 'aux/video' standby button  on the remote commander twice. 'TT __' will appear in the upper right corner of the screen. Other status information will also be displayed.
4. Press 'MENU' on the remote commander to obtain the following menu on the screen.

Service Main Menu:AE6BA/Y (v0.26D) NVM VERSION:04H	
Service	▶
Design	
Error	
Select: ▲ ▼ Select Item: ▶ FACTORY INFO:FFH FFH 03H	

5. Move to the corresponding adjustment item using the up or down arrow buttons on the Remote Commander.
6. Press the right arrow button to enter into the required menu item.
7. Press the 'aux/video' button on the Remote Commander to quit the Service Mode when all adjustments have been completed.

Note :

- After carrying out the service adjustments, to prevent the customer accessing the 'Service Menu' switch the TV set OFF and then ON.

Service	
Geometry	▶
Picture	
Audio	
Select: ▲ ▼ Select Item: ▶ Previous Menu: ◀	

Geometry	
Wide mode adjustment	▶
Screen offsets	
Frequency offsets	
Select: ▲ ▼ Select Item: ▶ Previous Menu: ◀	

Wide mode adjustment			
Description	(min,max)	Default	Value
V AMP	(-128,127)	35	35 ▶
V ZOOM	(0,510)	256	256
V POS	(-512,511)	-10	-10
V LIN	(-128,127)	0	0
V SCORR	(-128,1270)	4	4
H WIDTH	(-256,255)	63	63
V TRAP	(-128,127)	1	1
PIN AMP	(-511,511)	-80	-80
UP COR	(-128,127)	-1	-1
LOW COR	(-128,127)	-2	-2
H POS	(-600,600)	10	10
ANGLE	(-511,511)	-1	-1
BOW	(-511,511)	8	8
H LIN	(0,255)	85	84
H TRAP	(0,255)	138	138
H SCORR	(0,255)	100	100
UP COR 6	(-128,127)	-1	-1
LOW COR 6	(-128,127)	0	0
PIN UNBAL	(-240,240)	-40	-40
MID PIN	(-240,240)	-60	-60
Select: ▲ ▼ Select Item: ▶ Previous Menu: ◀			

Picture	
White balance	▶
Colour Tone	
Picture settings	
Select: ▲ ▼ Select Item: ▶ Previous Menu: ◀	

Picture settings			
Description	(min,max)	Default	Value
SUBCOLOR PAL	(0,63)	31	34 ▶
SUBCOLOR SECAM	(0,63)	31	34
SHP MAXLTI	(0,31)	31	20
SHP MAXPEAK	(0,15)	15	12
CONTRAST MIN	(0,63)	17	17
CONTRAST MAX	(0,63)	59	59
BRIGHT EXPAND	(0,511)	400	400
BRIGHT CENTER	(-256,255)	10	40

Select: ▲ ▼ Select Item: ▶ Previous Menu: ◀

Audio	
BBE OFF mode	▶
BBE Natural/V.Dolby offsets	
BBE Dynamic offsets	
BBE Cinema offsets	
Subwoofer level adjustments	
Audio detection thresholds	

Select: ▲ ▼ Select Item: ▶ Previous Menu: ◀

BBE OFF mode			
Description	(min,max)	Default	Value
SW_FREQ_OFF	(5,40)	20	20 ▶
BAND1_OFF_OFFSET	(-96,96)	0	0
BAND2_OFF_OFFSET	(-96,96)	0	0
BAND3_OFF_OFFSET	(-96,96)	0	0
BAND4_OFF_OFFSET	(-96,96)	0	0
BAND5_OFF_OFFSET	(-96,96)	0	0
BBE_LOUDNESS_OFF	(0,68)	0	0

Select: ▲ ▼ Select Item: ▶ Previous Menu: ◀

Design	
CXA2149 - AVSwitch Device	▶
DDP3315 - Backend Device	
MSP3411 - Sound Processor Device	
TDA988x - IF Device	
TUA60xx - PLL Device	
VSP9427 - Video Processor Device	
CXA2019 - Chroma Decoder	
CXD3804 - 3D Comb Filter	
CXA8070 - Dynamic Convergence Device	
FRC9429 - FRCA Device	
PJ Engine	

Select: ▲ ▼ Select Item: ▶ Previous Menu: ◀

Error monitor		
WORKING TIME:	(Hours:Minutes)	82:33
Error counters:		
E02: OCP		0
E03: OVP		0
E04: NO V SYNC		0
E05: IKR		0
E06: IIC		0
E07: NVM		0
E08: H PROT		0
E09: TUNER		0
E10: SOUND		0
E11: 9 VOLTS		0
E12: SCANRATE		0
E13: 3DCOMB		0
E14: BACKEND		0
E15: DYNCON		0
E16: HIGH VOLTAGE		0
E17: AVSWITCH		0
E18: CHROMA DEC		0
E19: FRCA		0
E20: PJ ENG		0
E21: DAC		0
E24: SPEAKER PROT		0
E25: MEMORY STICK		0

Select: ▲ ▼ Previous Menu: ◀

Sub Brightness Adjustment

1. Input a Monoscope pattern.
2. Program the Remote Commander for operation in Service Mode. [See Page 22].
3. Press 'AUX/VIDEO' 'AUX/VIDEO' 13 on the Remote Commander.
4. Adjust the 'Sub-Brightness' data so that there is barely a difference between the 0 IRE and 10 IRE signal levels.

Sub Contrast Adjustment

1. Input a video signal that contains a small 100% white area on a black background.
2. Connect an oscilloscope to Pin 10 of J7330 [C Board].
3. Program the Remote Commander for operation in Service Mode. [See Page 22].
4. Adjust the Sub-Contrast [Using 'AUX/VIDEO' 'AUX/VIDEO' '11'] to obtain a voltage of 114 +/- 5V.

Sub Colour Adjustment

1. Receive a PAL colour bar signal.
2. Connect an oscilloscope to Pin 5 of CN7331 [C Board].
3. Program the Remote Commander for operation in Service Mode. [See Page 22].
4. Adjust the 'Sub Colour'
[Using 'AUX/VIDEO' 'AUX/VIDEO' '12'] so that the Cyan, Magenta and Blue colour bars are of equal levels as indicated below.

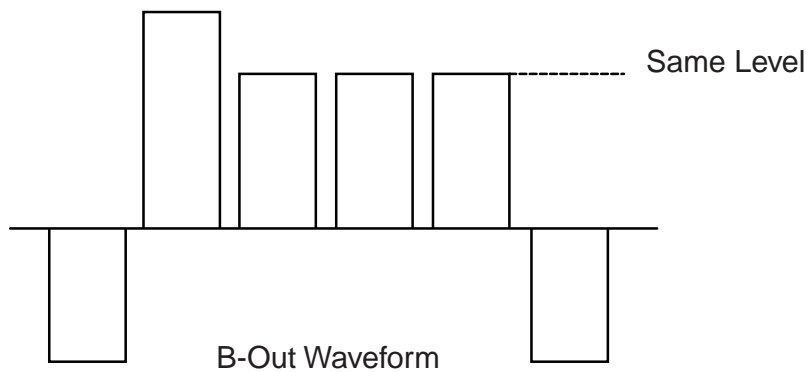

Deflection System Adjustment

1. Program the Remote Commander for operation in Service Mode. [See Page 22] and enter into the 'Geometry' service menu, Wide mode adjustment.
2. Select and adjust each item in order to obtain the optimum image.

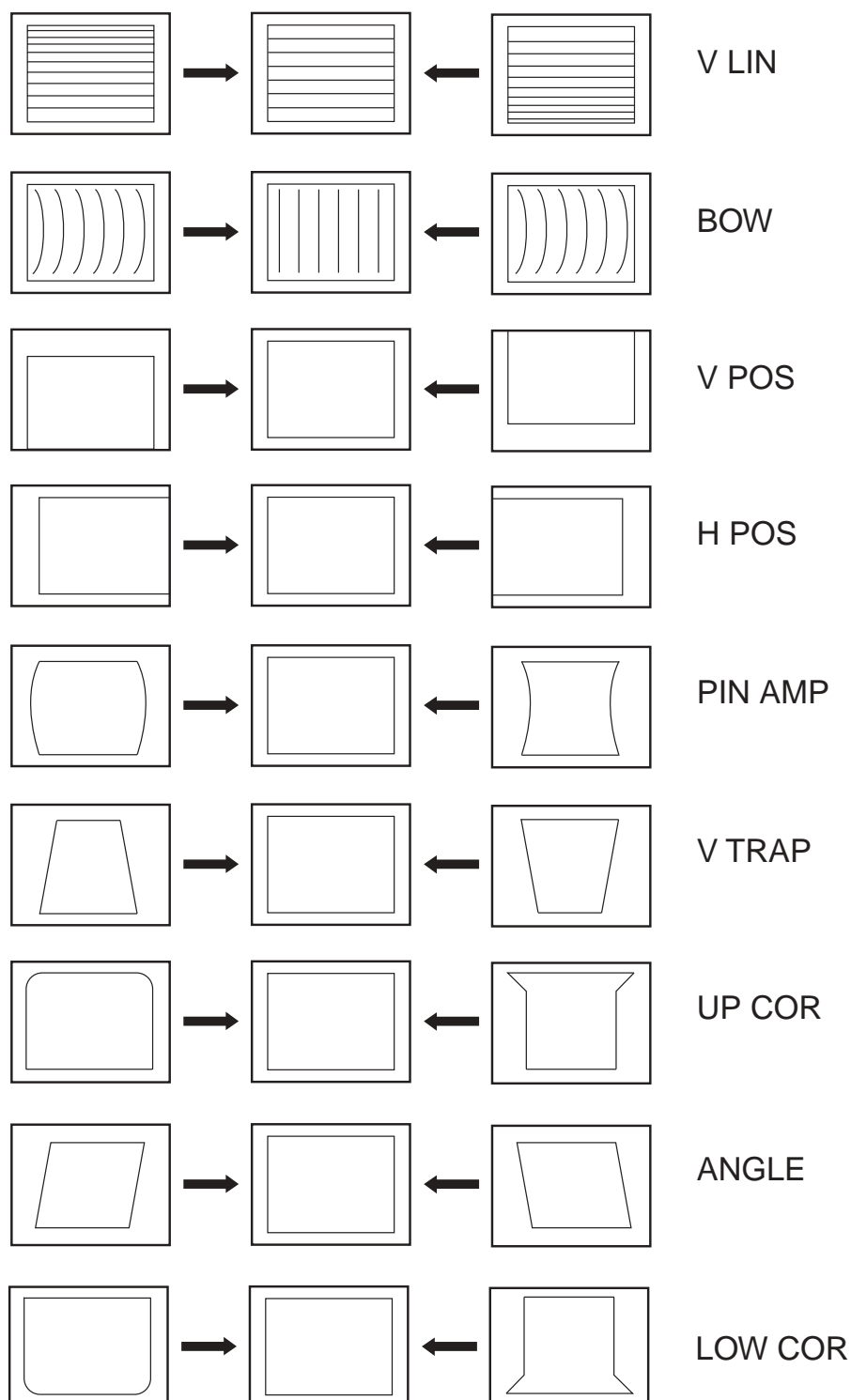

4-2. TEST MODE 2:

Test Mode 2 is available by programming the Remote Commander for operation in Service Mode [As shown on Page 22] then pressing the 'AUX/VIDEO' button twice, OSD 'TT' appears. The functions described below are available by selecting the two numbers. To release 'Test mode 2', press 00, or switch the TV set into Stand-by mode.

00	'TT' mode off
01	Set picture level to maximum
02	Set picture level to minimum
03	Set speaker/headphone Volume to 35%
04	Set speaker/headphone Volume to 50%
05	Set speaker/headphone Volume to 65%
06	Set speaker/headphone Volume to 80%
07	Ageing mode on
08	Shipping Condition
11	Sub picture adjustment
12	Sub colour adjustment
13	Sub brightness adjustment
15	Rotation coil test
16	Picture level 50%
19	Factory mode enable/disable
21	Destination ADEKR
22	Destination BL
24	Destination U
35	Wide model selection
36	VM off/on test
43	Select Dual A sound
44	Select Dual B sound
45	Select Mono sound
46	Select Stereo sound
49	Set NVM as virgin
53	FM Overmodulation enable/disable
62	AM from baseband enable/disable
73	Enable Zweiton D/K2 system (6.5/6.74)
74	Enable Zweiton D/K3 system (6.5/6.74)
78	Balance full left
79	Balance full right
87	Local keys test
91	Set 14:9 zoom mode
92	Set Smart zoom mode
93	Set 16:9 zoom mode
94	Set ZOOM zoom mode
95	Set 4:3 zoom mode
96	Set Smart zoom mode (for FX66)
99	DisplayError and Working Time menu

5-1. BLOCK DIAGRAMS (1)

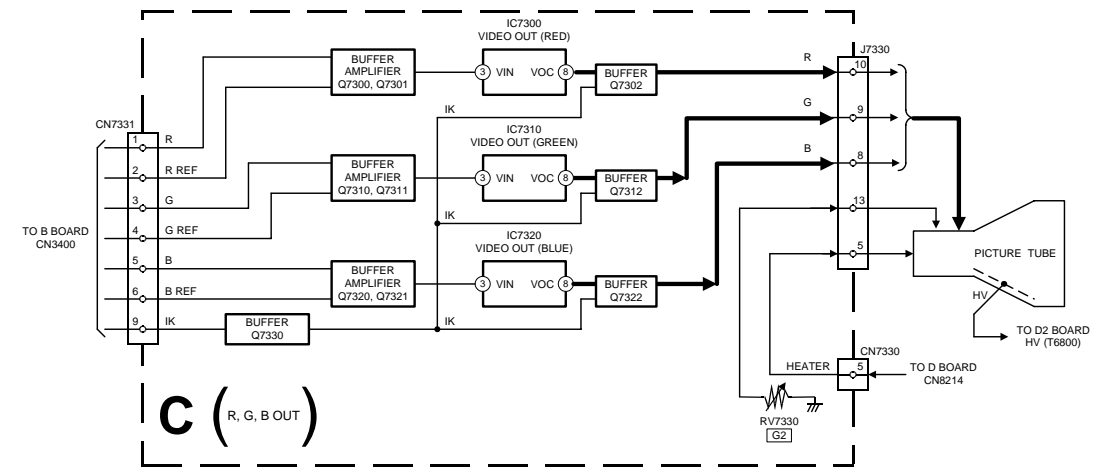
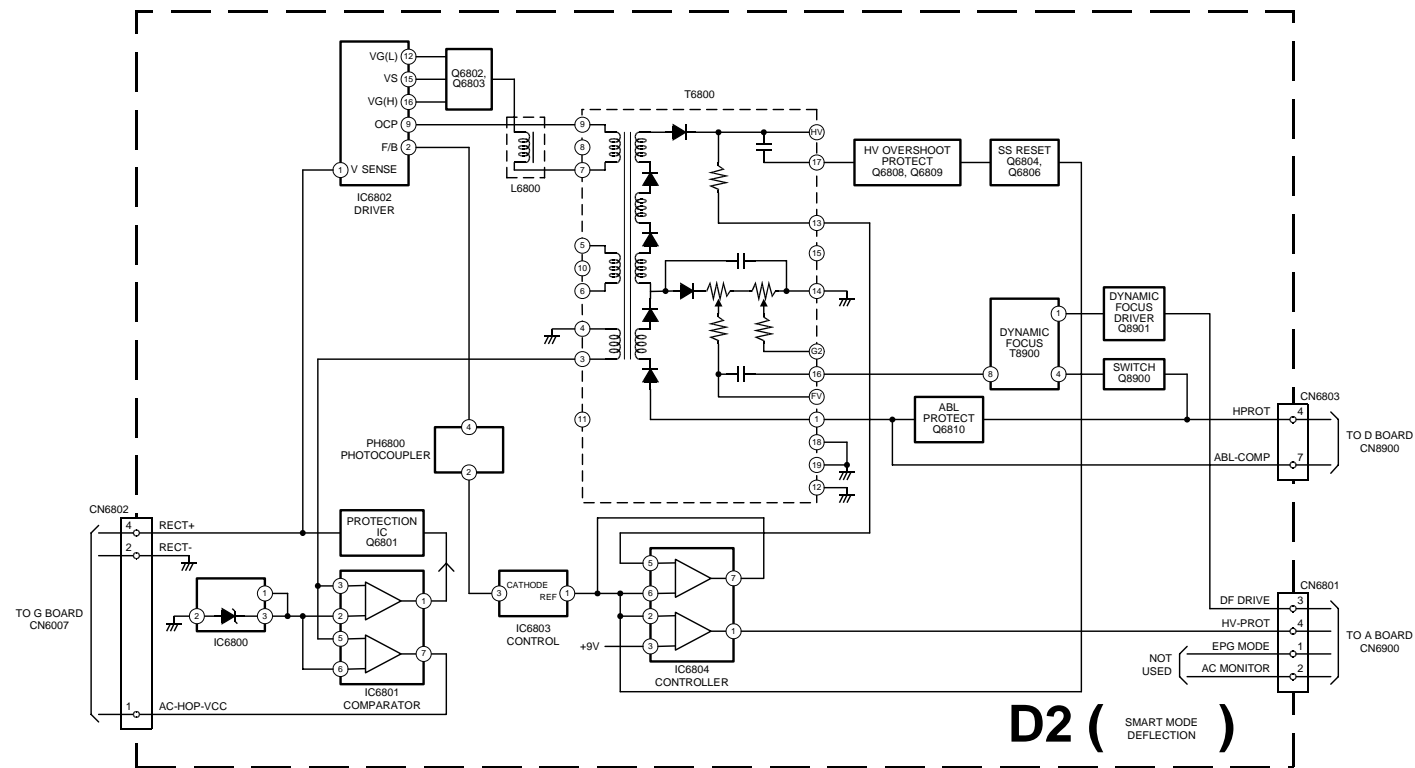
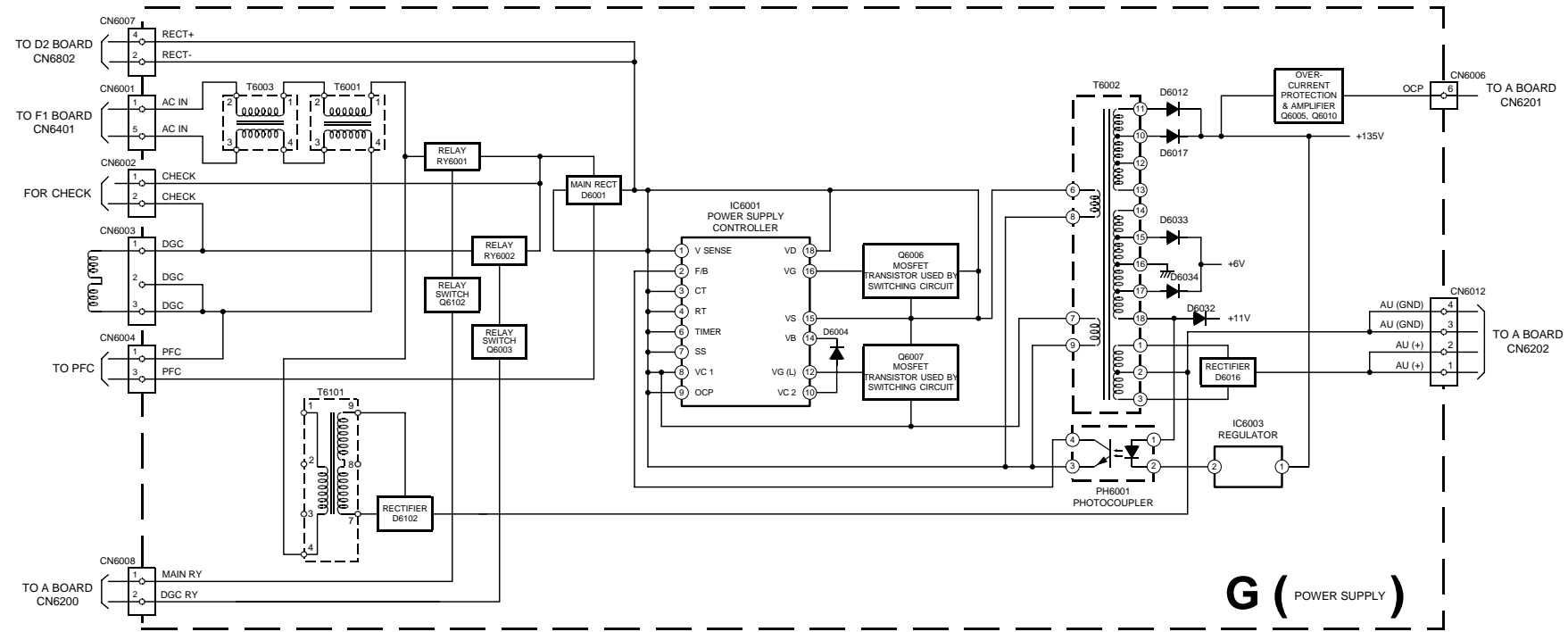

5-1. BLOCK DIAGRAMS (2)

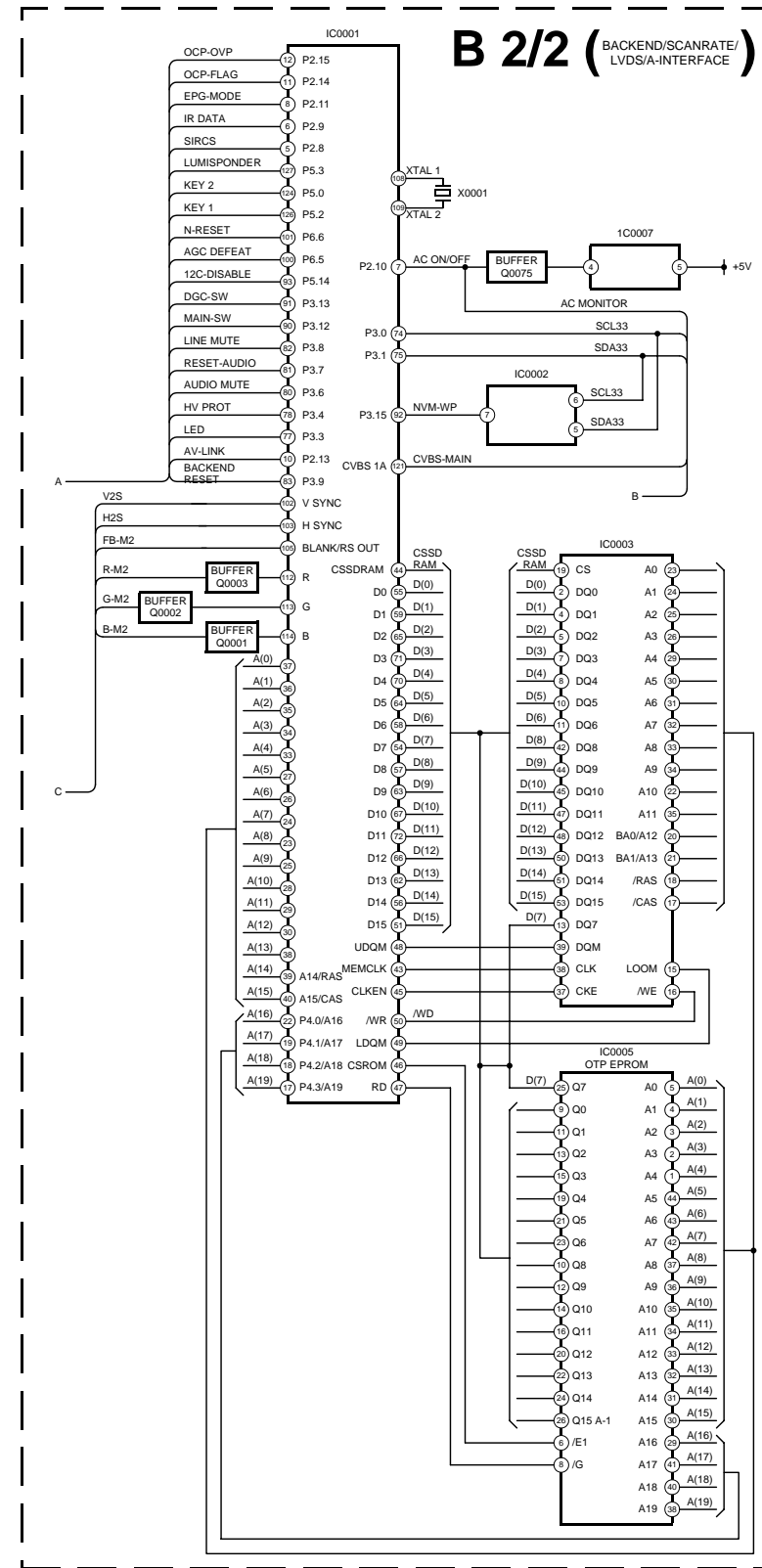
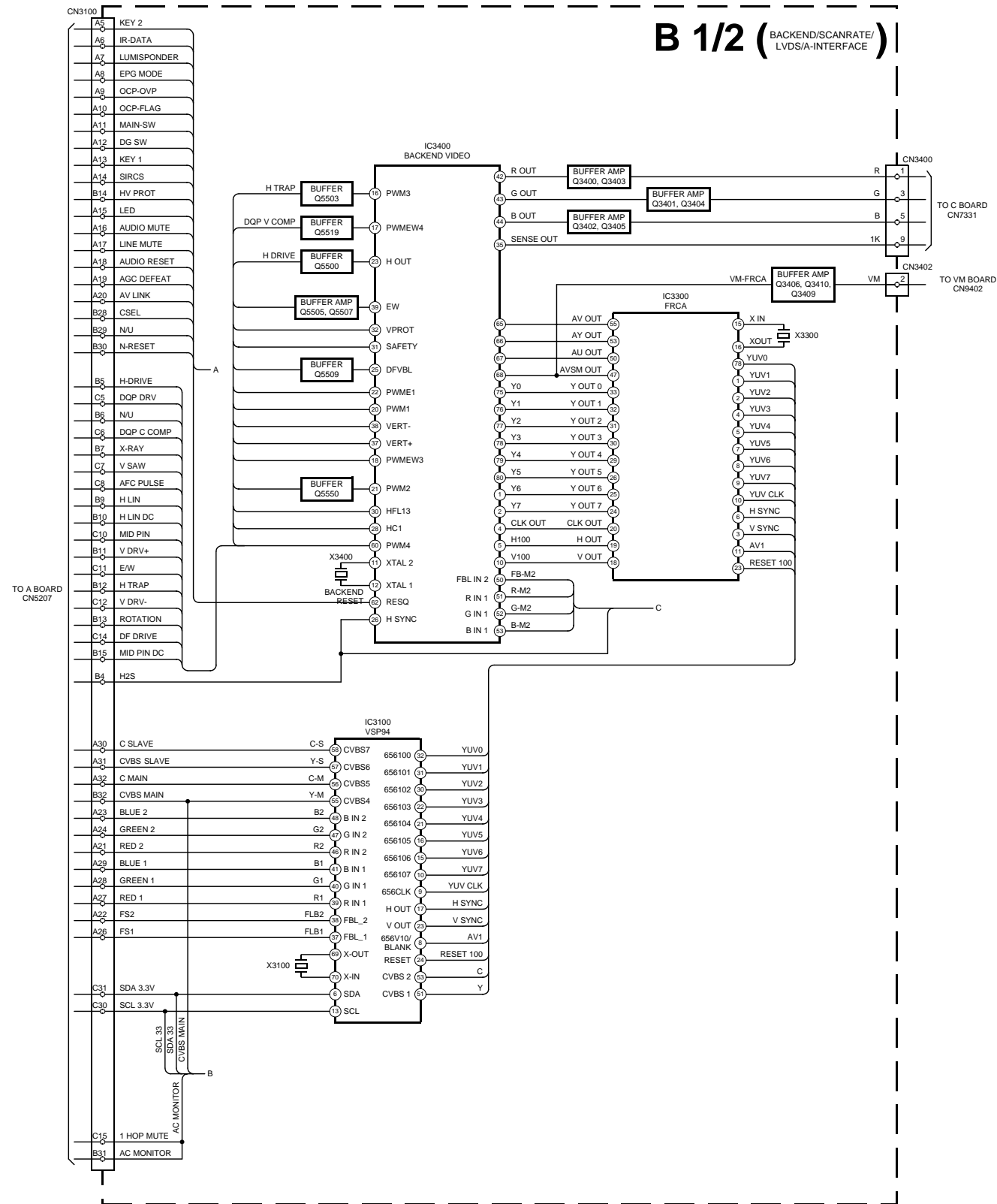

5-1. BLOCK DIAGRAMS (3)

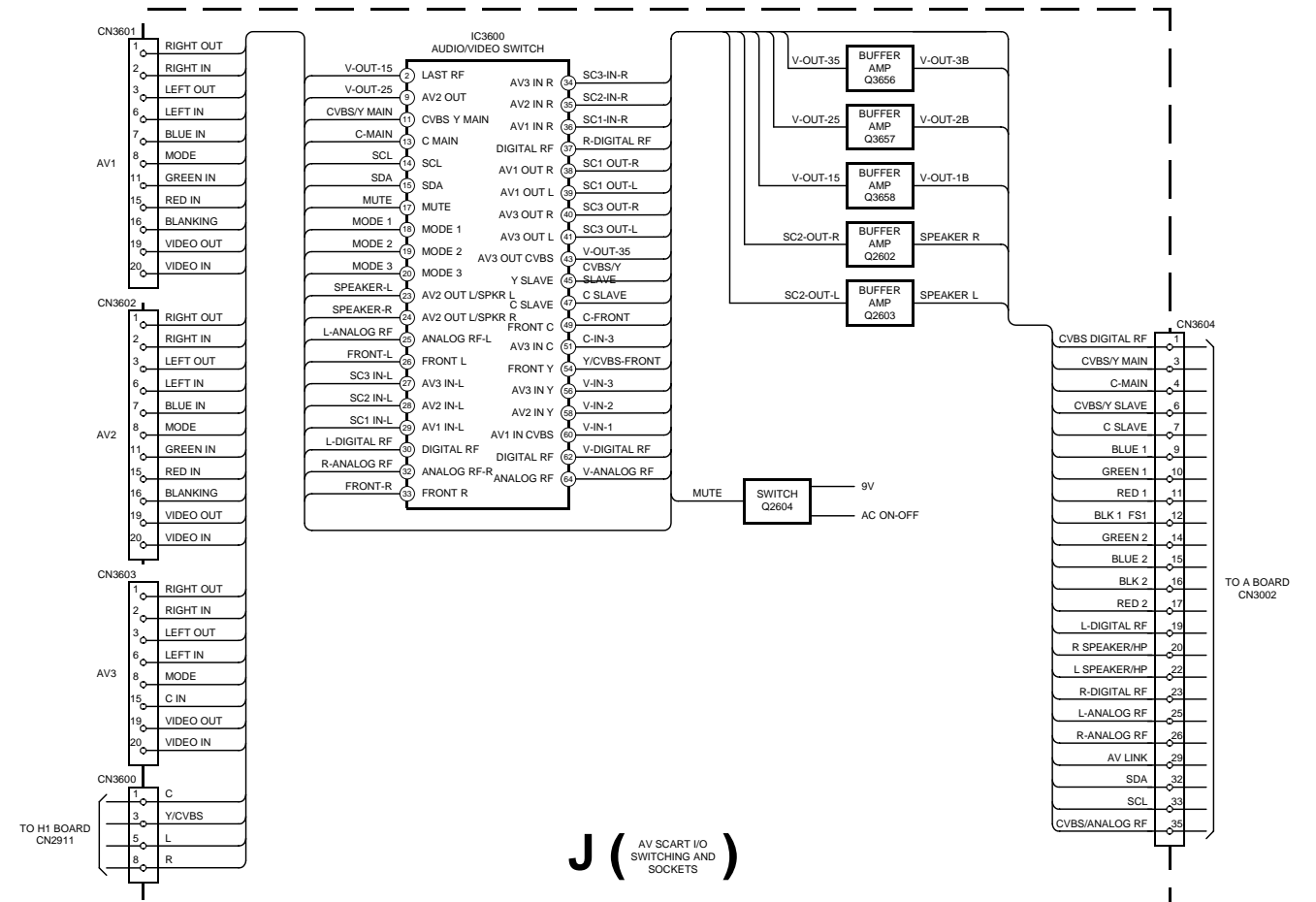
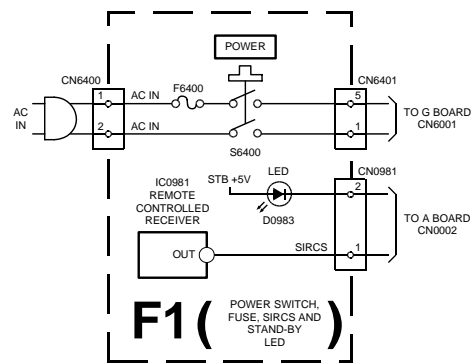
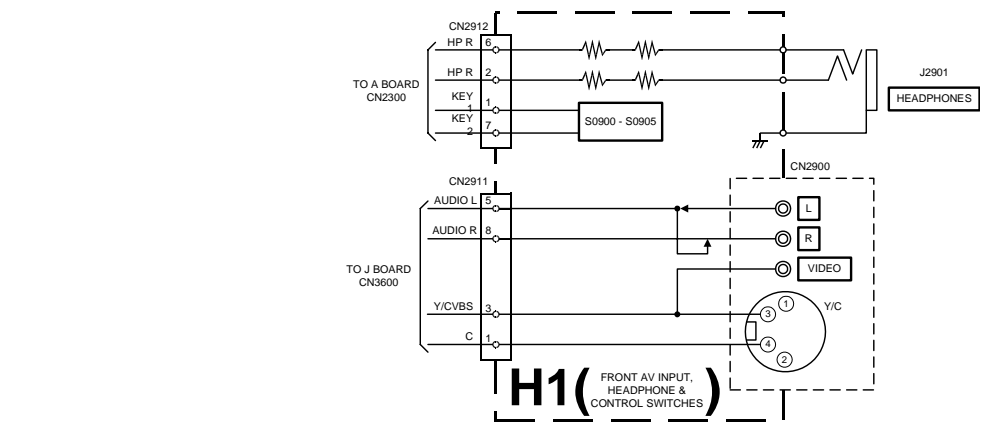
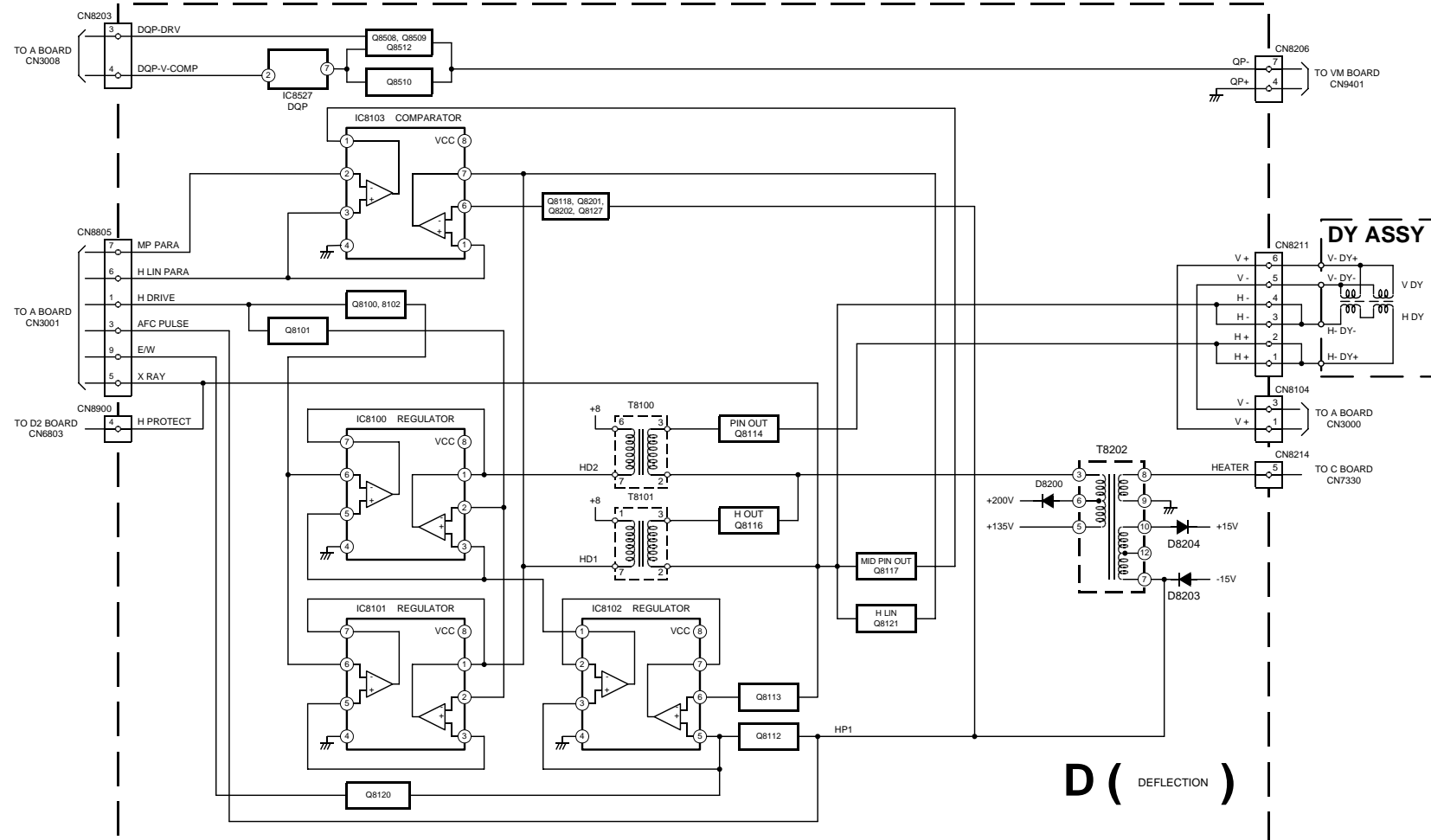

5-1. BLOCK DIAGRAMS (4)

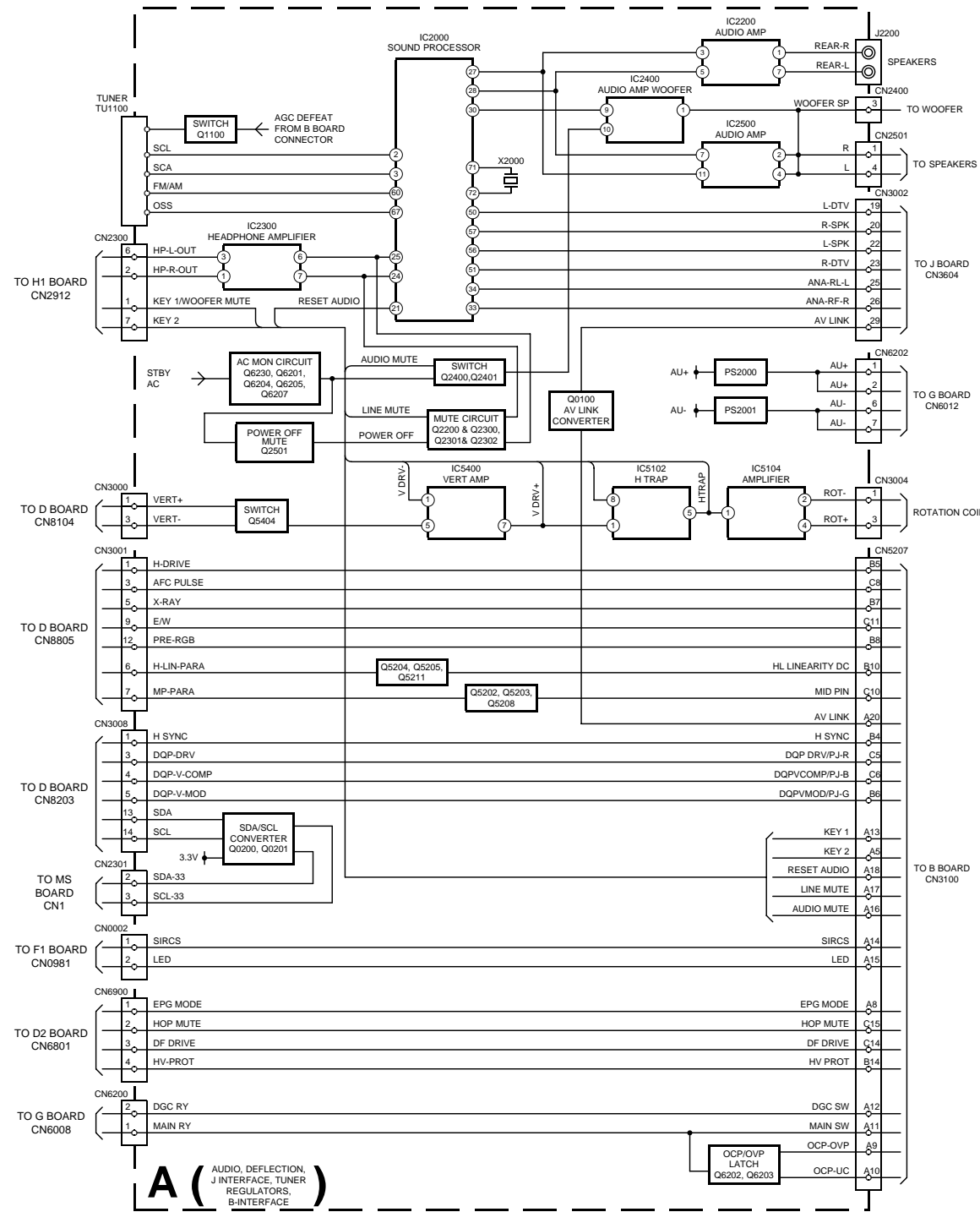

5-2. CIRCUIT BOARD LOCATION

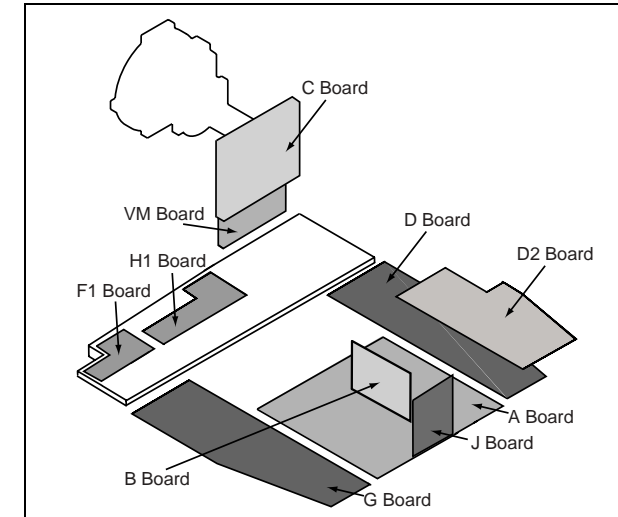

5-3. SCHEMATIC DIAGRAMS AND PRINTED WIRING BOARDS

Note :

- All capacitors are in μF unless otherwise noted.
- pF : μF 50WV or less are not indicated except for electrolytic types.
- Indication of resistance, which does not have one for rating electrical power, is as follows.

Pitch : 5mm
Electrical power rating : 1/4W

- Chip resistors are 1/10W
- All resistors are in ohms.
 $k = 1000 \text{ ohms}$, $M = 1000,000 \text{ ohms}$

- : nonflammable resistor.
- : fusible resistor.
- : internal component.
- : panel designation or adjustment for repair.

- All variable and adjustable resistors have characteristic curve B, unless otherwise noted.
- All voltages are in Volts.
- Readings are taken with a 10Mohm digital multimeter.
- Readings are taken with a color bar input signal.
- Voltage variations may be noted due to normal production tolerances.

- : B + bus.
- : B - bus.
- : RF signal path.
- : earth - ground.
- : earth - chassis.

Reference Information

RESISTOR	RN	: METAL FILM
	RC	: SOLID
	FPRD	: NON FLAMMABLE CARBON
	FUSE	: NON FLAMMABLE FUSIBLE
	RS	: NON FLAMMABLE METAL OXIDE
	RB	: NON FLAMMABLE CEMENT
	RW	: NON FLAMMABLE WIREWOUND
		: ADJUSTMENT RESISTOR
COIL	LF-8L	: MICRO INDUCTOR
CAPACITOR	TA	: TANTALUM
	PS	: STYROL
	PP	: POLYPROPYLENE
	PT	: MYLAR
	MPS	: METALIZED POLYESTER
	MPP	: METALIZED POLYPROPYLENE
	ALB	: BIPOLAR
	ALT	: HIGH TEMPERATURE
	ALR	: HIGH RIPPLE

Note : The components identified by shading and marked Δ are critical for safety. Replace only with the part numbers specified in the parts list.

Note : Les composants identifiés par une trame et par une marque Δ sont d'une importance critique pour la sécurité. Ne les remplacer que par des pièces de numéro spécifié.

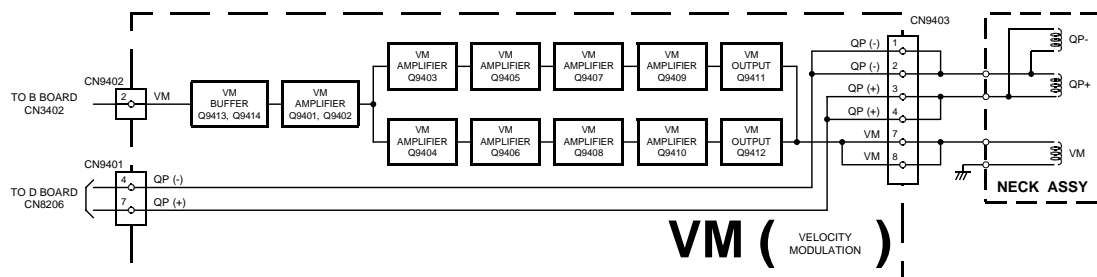

~ A Board Waveforms ~

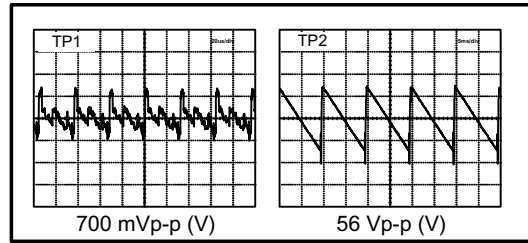

~ A Board Semiconductor Voltage Table ~

Ref	(e)(s)	(b)(g)	(c)(d)	Ref	(e)(s)	(b)(g)	(c)(d)	Ref	(e)(s)	(b)(g)	(c)(d)	Ref	(e)(s)	(b)(g)	(c)(d)	Ref	(e)(s)	(b)(g)	(c)(d)				
Q1100	0	0	4.5	Q2202	0	0.4	0	Q2500	0.1	0.1	0.6	Q5101	0.8	1.4	6.8	Q5208	0	0	1.5	Q6202	3.4	3.4	0
Q1300	2.7	2.1	8.4	Q2300	0	0	0.7	Q2501	0	0.6	0	Q5200	6.8	6.3	3.0	Q5209	0	0	1.5	Q6203	0	0	3.4
Q1301	2.1	2.1	0	Q2301	0	0.4	0	Q2502	0	0	5.0	Q5201	0	0.4	3.0	Q5210	0	0	1.5	Q6204	3.4	3.4	0
Q2000	0	0	4.7	Q2302	0	0.4	0	Q2503	0	0	5.0	Q5203	0	0.4	3.0	Q5211	0	0	1.5	Q6205	3.5	2.7	3.4
Q2200	0	0	-1.6	Q2400	3.9	3.4	0	Q2504	5.0	5.0	0	Q5205	0	0.4	1.5	Q5404	0	12.1	0	Q6206	1.5	2.0	2.7
Q2201	0	0.4	0	Q2401	0	0	4.7	Q5100	2.4	1.8	0	Q5207	0	0.4	3.0	Q6201	1.5	0.6	3.4	Q6207	0	0	3.4

~ A Board Location Table (A Side) ~

DIODE	D5405	D - 10	D6211	K - 4	IC2500	H - 3	IC6204	M - 4	
D2200	D - 3	D6201	J - 9	D6212	J - 9	IC5102	I - 10	IC6207	J - 10
D2201	E - 3	D6203	L - 5	D6213	L - 8	IC5104	H - 10	IC6209	J - 8
D5103	H - 10	D6204	K - 2	IC		IC5400	E - 10	IC6210	K - 4
D5404	E - 11	D6210	L - 4	IC2400	J - 4	IC6202	L - 8	IC6212	L - 3

~ A Board IC Voltage Table ~

IC Voltage Table			IC Voltage Table			IC Voltage Table			IC Voltage Table			IC Voltage Table		
Ref No	Pin No	Voltage (V)	Ref No	Pin No	Voltage (V)	Ref No	Pin No	Voltage (V)	Ref No	Pin No	Voltage (V)	Ref No	Pin No	Voltage (V)
IC2200	1	4.5	IC2300	6	0	IC2400	12	-4.0	IC5102	2	0	IC5400	7	0.4
	2	4.5		7	0		2	0		5	2.5			
	3	4.5		8	0.5		5	0.9		6	2.5			
	5	4.5	IC2500	1	0		7	0	8	2.2				
	6	4.5		2	-4.0		8	0	IC5104	1	14.6			
	7	4.5		3	10.0		9	0	IC5400	1	0.4			
	IC2300	1		4.0	5		0	10		0	3		-12.3	
3		4.0	6	-13.2	11	0	5	0						
5		0.5	10	3.9	IC5102	1	17.1	6	15.7					

~ A Board Location Table (B Side) ~

DIODE	D5206	G - 7	D6204	E - 2	IC2200	L - 4	IC6207	F - 9	Q1300	L - 2	Q2401	F - 4	Q5202	H - 4	Q5404	K - 10	
D2200	L - 3	D5207	G - 6	D6205	E - 3	IC2300	J - 3	IC6209	F - 9	Q1301	K - 2	Q2500	H - 3	Q5203	H - 4	Q6201	E - 2
D2201	J - 4	D5208	H - 6	D6206	D - 3	IC2400	G - 4	IC6210	F - 4	Q2000	J - 3	Q2501	H - 3	Q5204	G - 7	Q6202	E - 3
D2202	J - 4	D5209	G - 7	D6207	D - 3	IC2500	H - 3	IC6211	E - 5	Q2200	I - 4	Q2502	H - 4	Q5205	F - 6	Q6203	E - 3
D2500	H - 3	D5210	G - 6	D6208	D - 3	IC5102	G - 10	IC6212	E - 4	Q2201	L - 3	Q2503	H - 4	Q5206	H - 7	Q6204	E - 3
D5100	G - 10	D5211	G - 6	D6210	D - 3	IC5104	H - 10	TRANSISTOR	Q2202	L - 3	Q2504	H - 4	Q5207	H - 6	Q6205	E - 2	
D5104	H - 9	D5404	K - 10	D6213	D - 8	IC5400	K - 10		Q0100	K - 6	Q2300	I - 4	Q5100	G - 10	Q5208	G - 7	Q6206
D5200	F - 7	D5405	L - 10	D6214	E - 4	IC6200	E - 5	Q0200	K - 7	Q2301	I - 4	Q5101	F - 10	Q5209	H - 6	Q6207	E - 2
D5202	F - 6	D6201	F - 9	IC		IC6202	D - 8	Q0201	K - 7	Q2302	J - 4	Q5200	F - 6	Q5210	G - 6	Q6208	E - 3
D5205	G - 7	D6203	D - 5	IC2000	K - 4	IC6204	E - 4	Q1100	M - 2	Q2400	F - 4	Q5201	F - 6	Q5211	G - 6	Q6209	E - 4

~ A Board Difference Table ~

Ref	KV-28FQ86B	KV-28FQ86E	KV-32FQ86B	KV-32FQ86E	KV-32FQ86K	KV-32FQ86U
TU1100	FRONTEND BTF-EF411	FRONTEND BTF-EC411	FRONTEND BTF-EF411	FRONTEND BTF-EC411	FRONTEND BTF-EC411	FRONTEND BTF-EU611

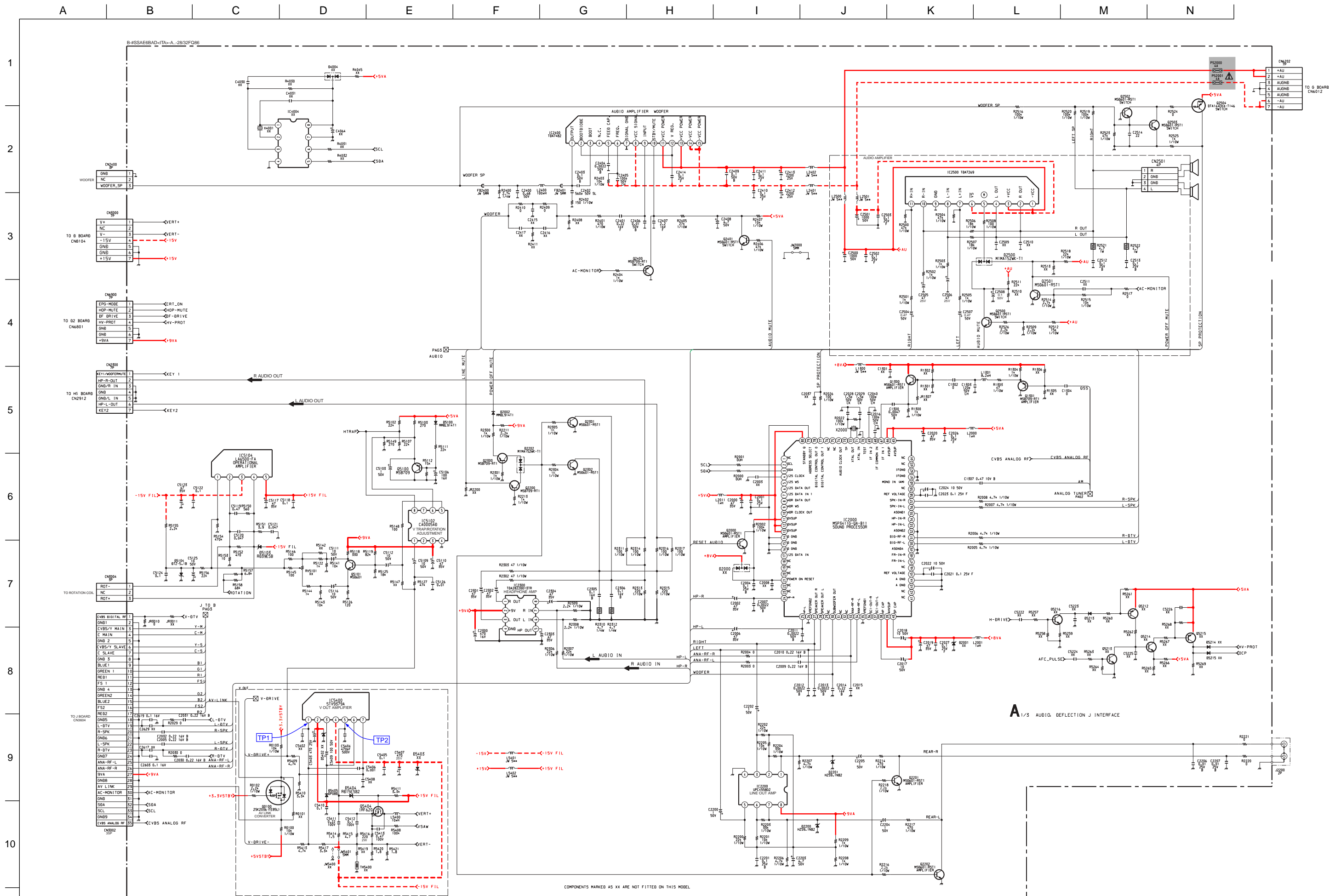

~ A Board Schematic Diagram [Audio, Deflection J Interface] Page 1/3 ~

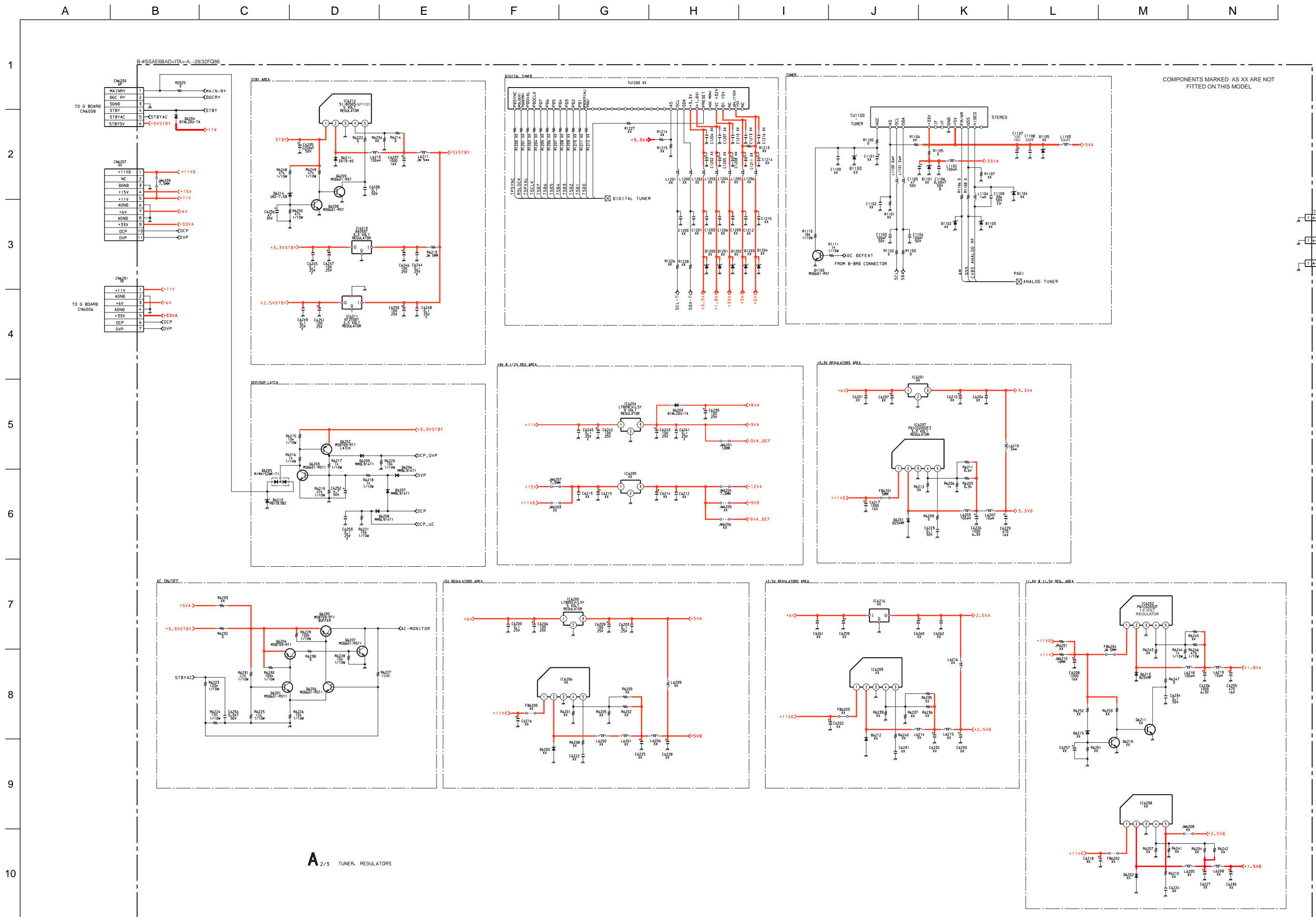

A 2/3 TUNER, REGULATORS

1

2

3

4

5

6

7

8

9

10

11

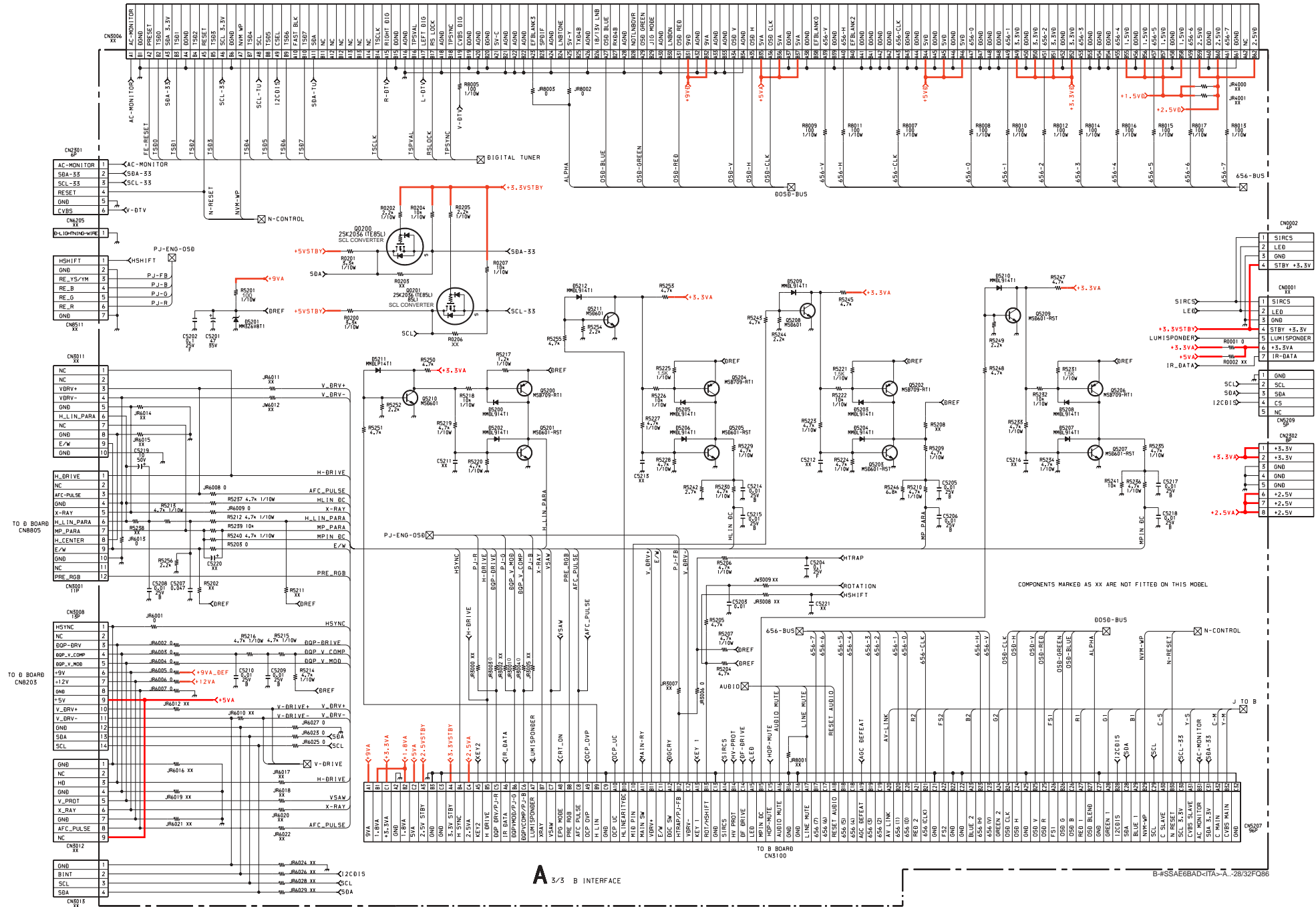

~ A Printed Wiring Board Conductor side A ~

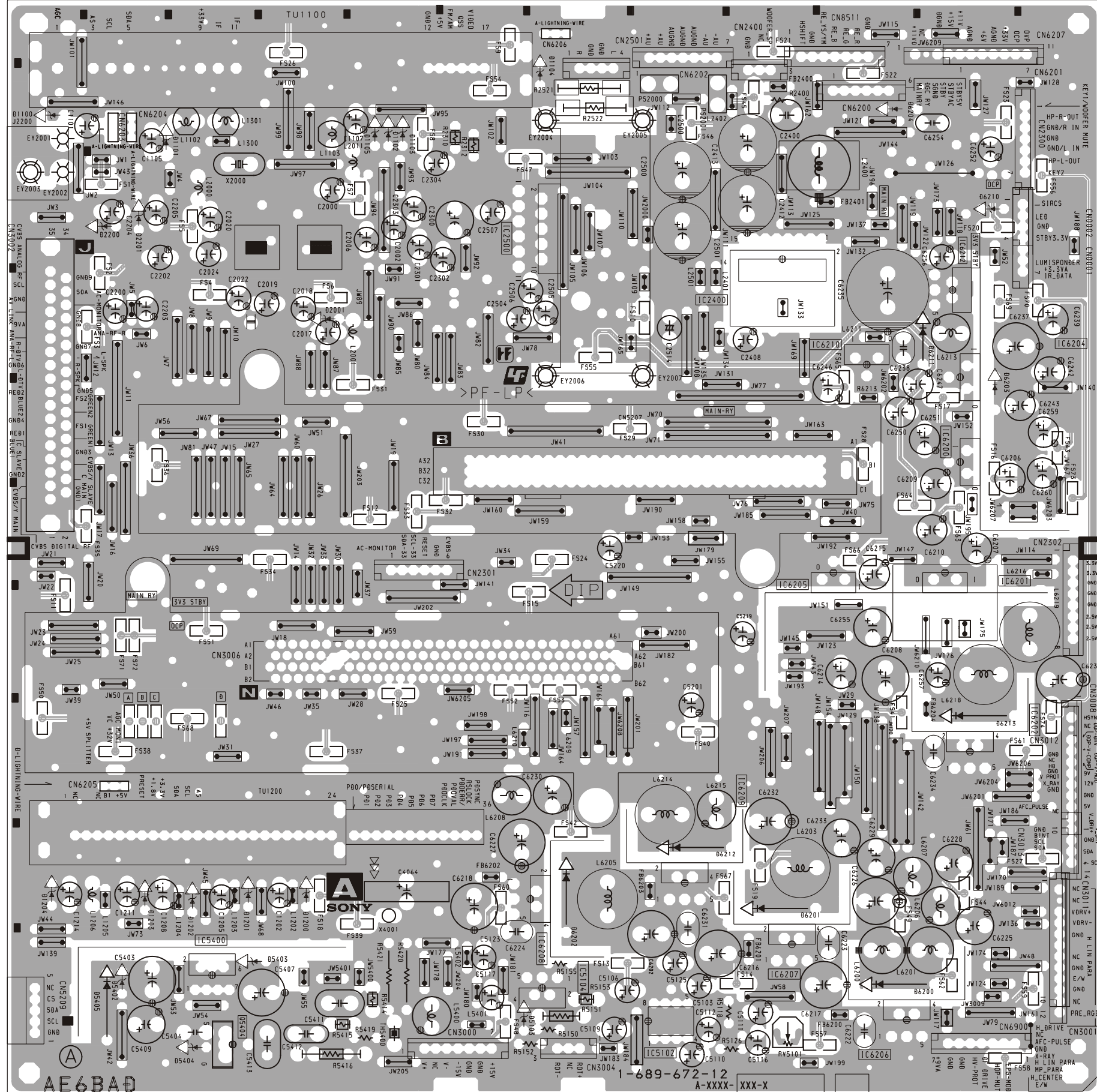

~ A Printed Wiring Board Conductor side B ~

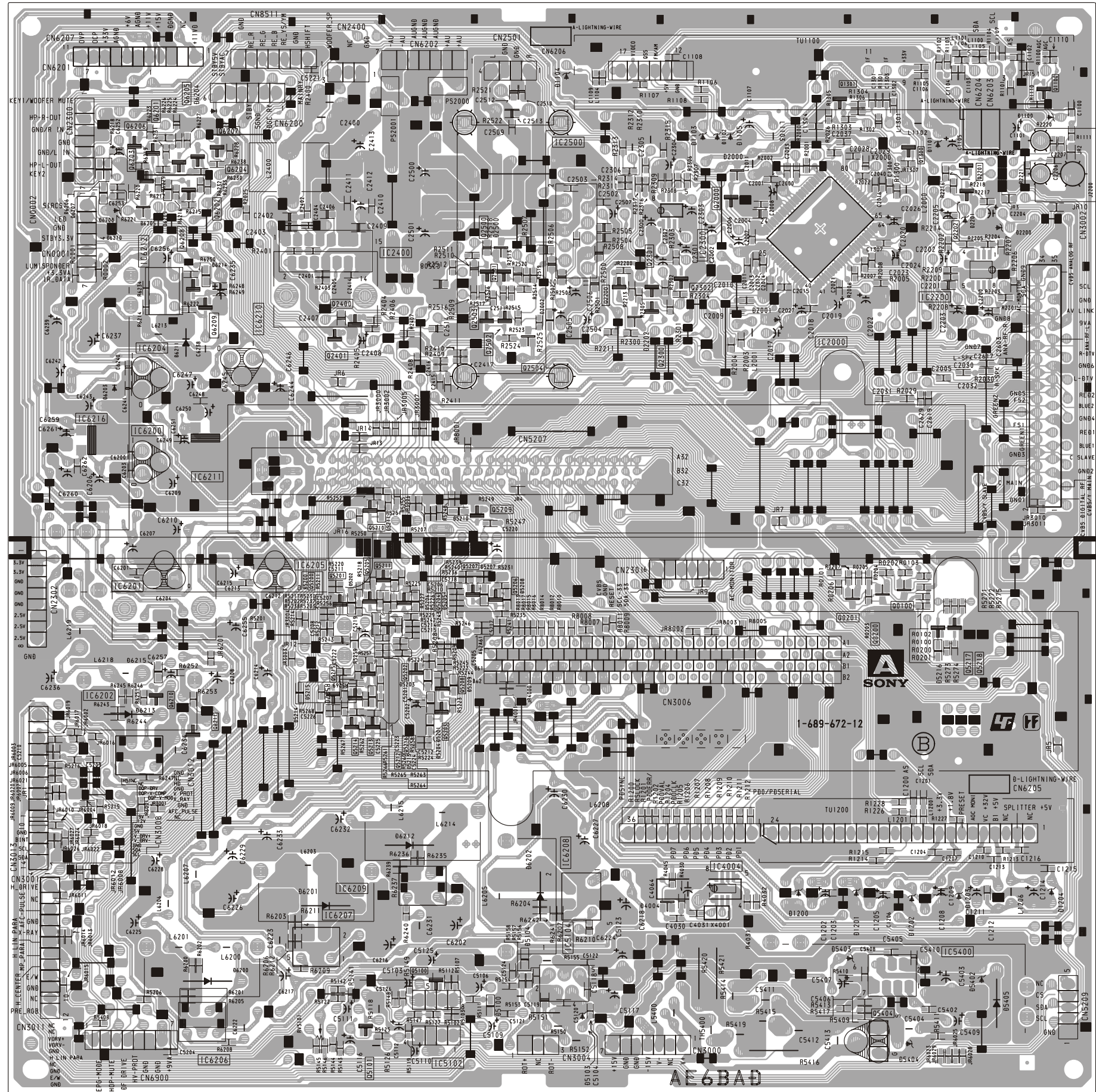

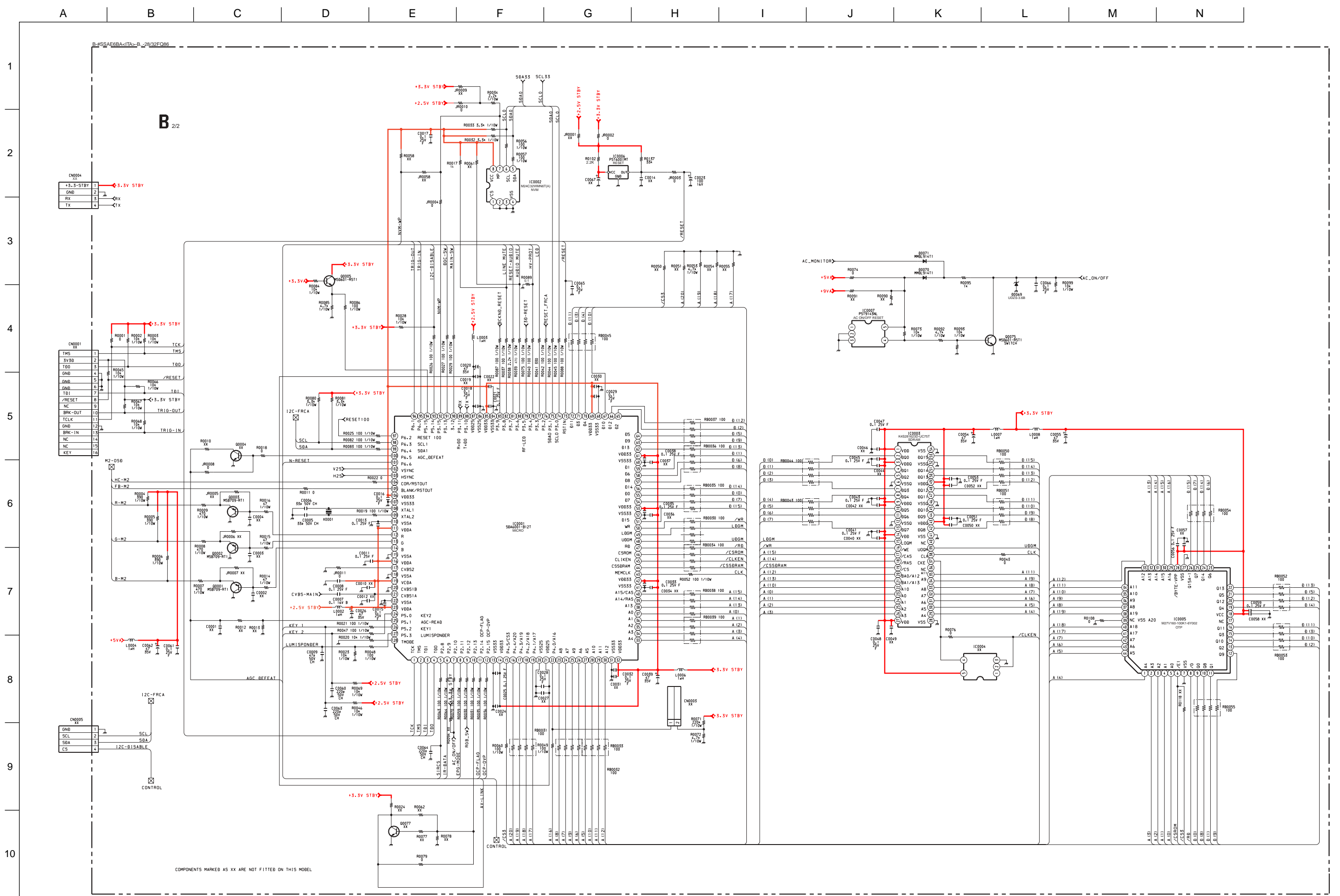

~ B Board Schematic Diagram [Backend,Scanrate,LVDS,A_Interface] Page 2/2 ~

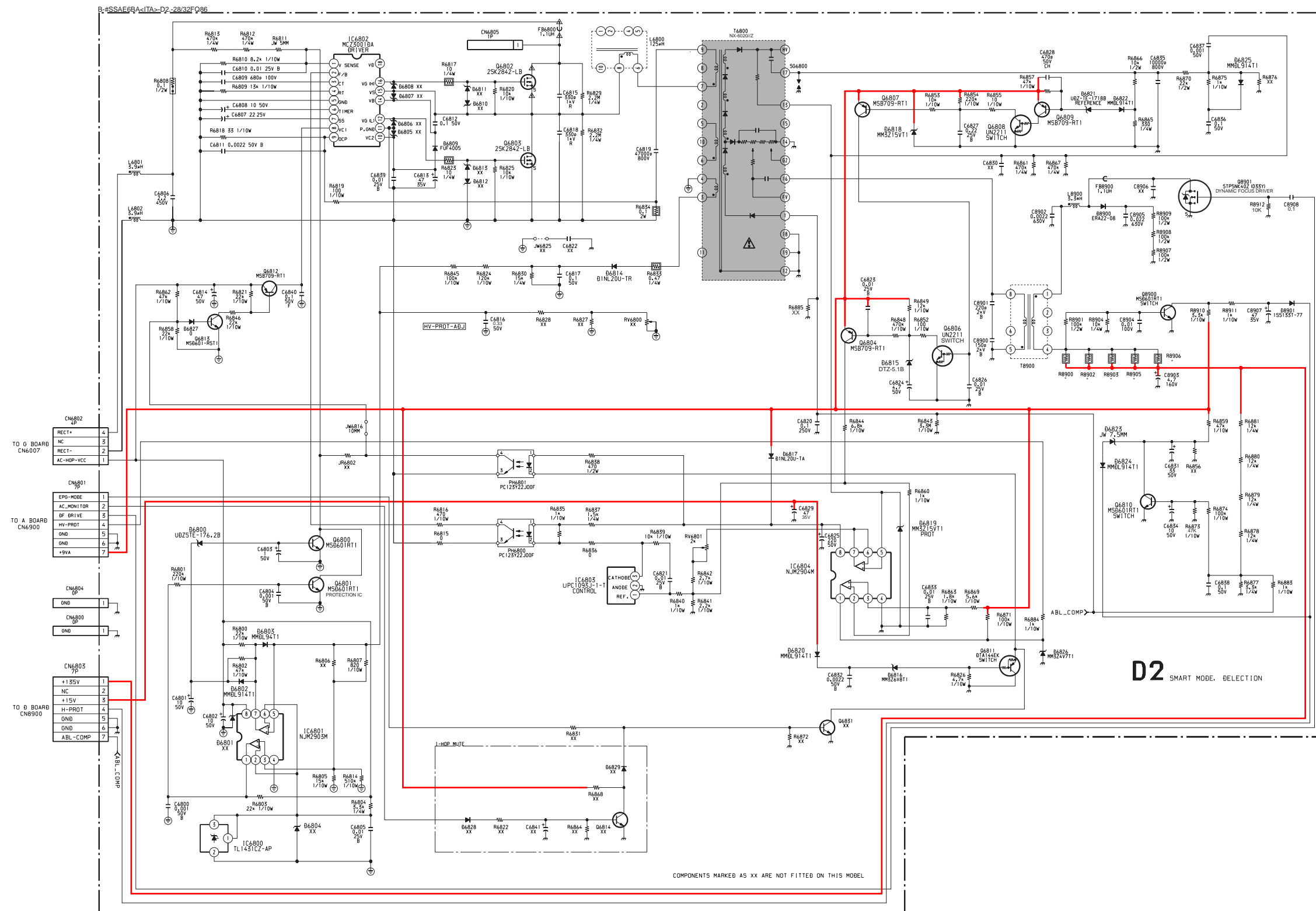

~ D2 Board Schematic Diagram [Smart Mode Deflection] ~

~ F1 Board Schematic Diagram [Power Switch, Fuse, SIRCS and Stand-By LED] ~

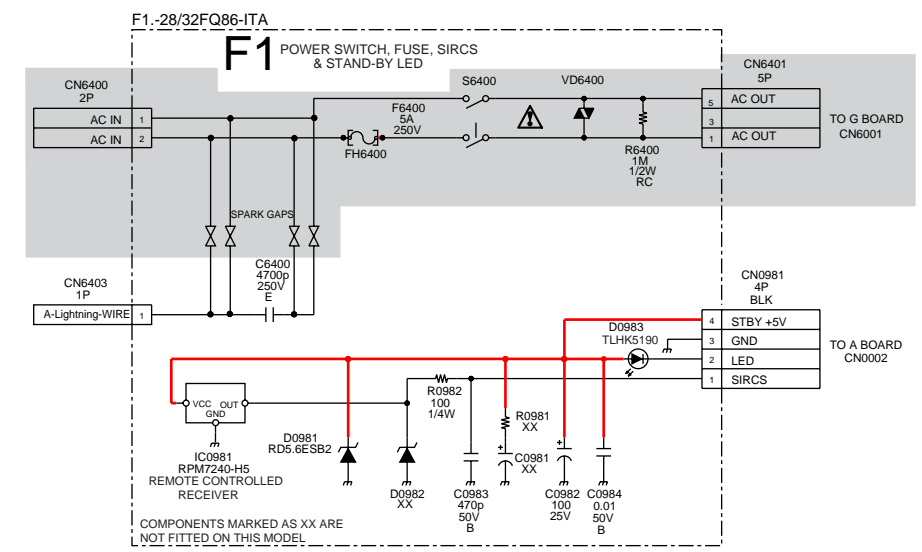

~ H1 Board Schematic Diagram [Front AV Input, Headphone and Control Switches] ~

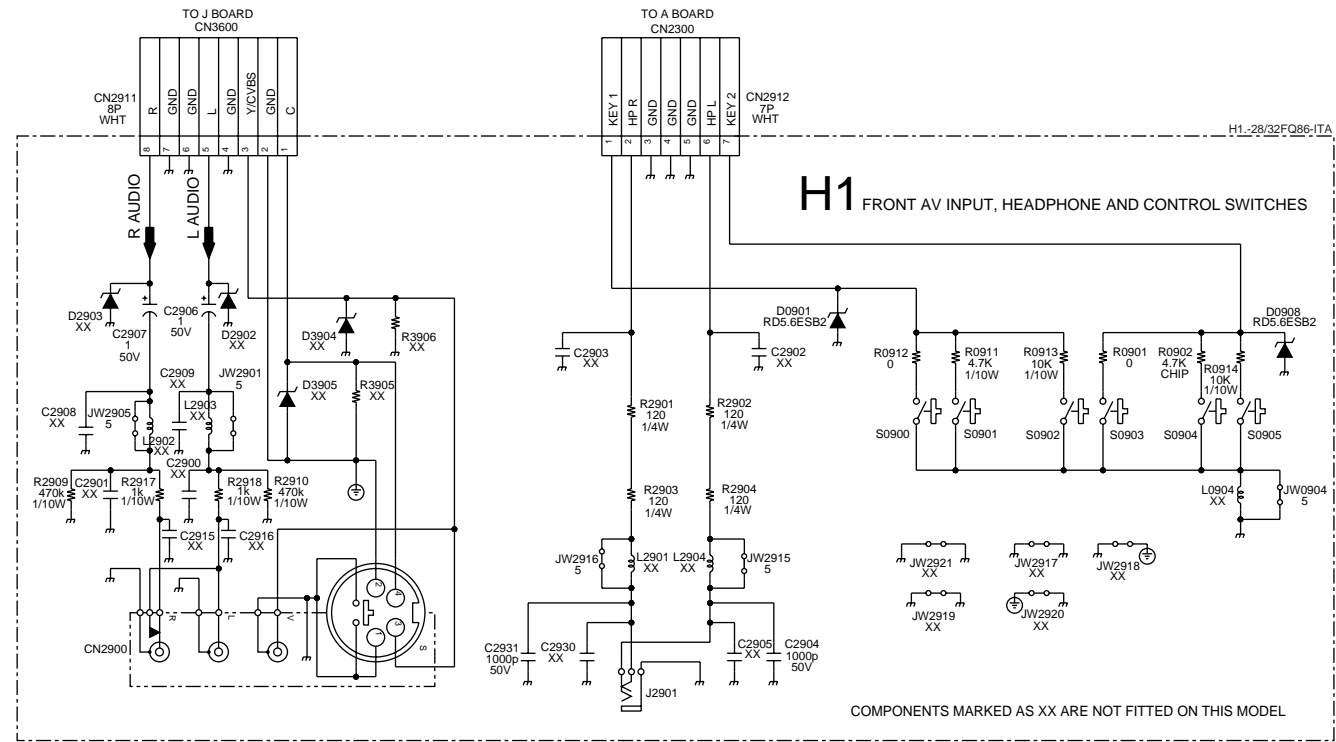

~ VM Board Schematic Diagram [Velocity Modulation] ~

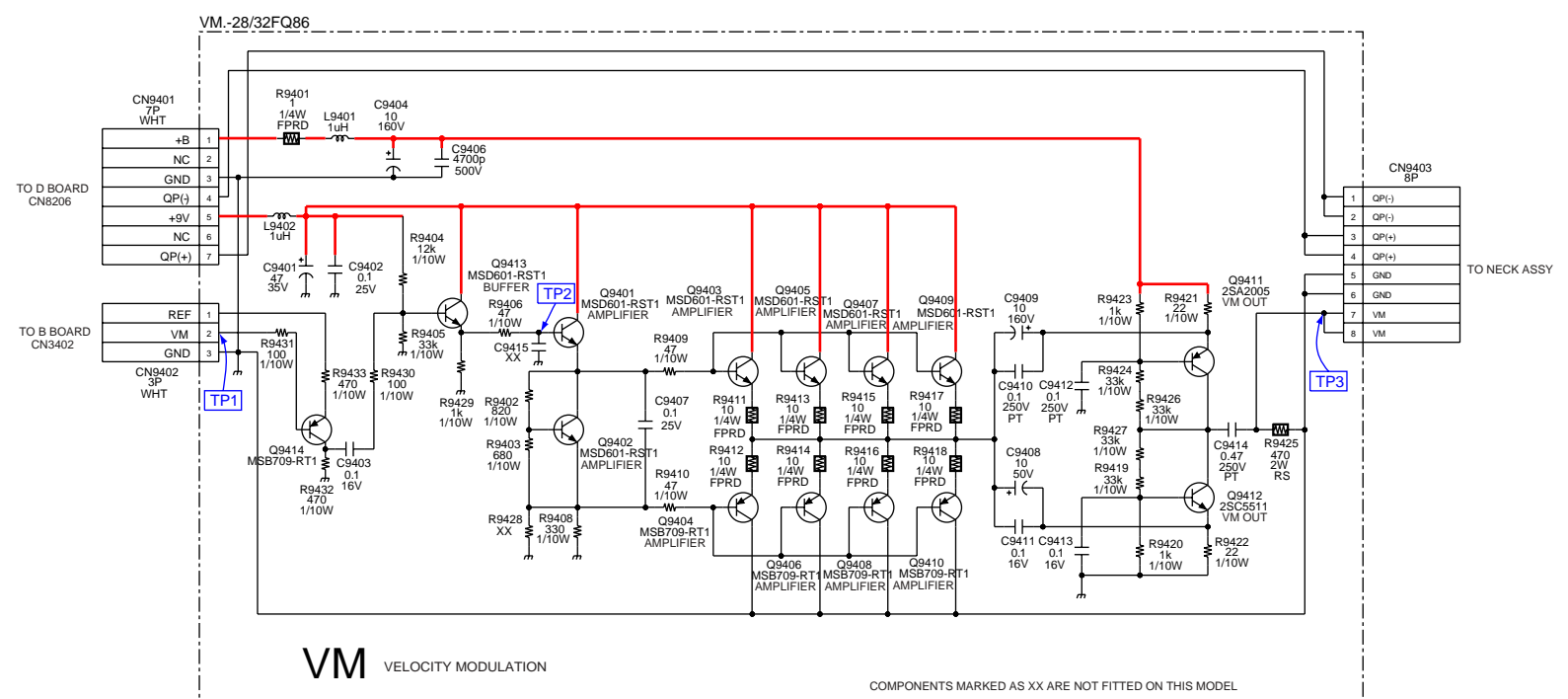

~ VM Board Voltage Table ~

Ref	(e)(s)	(b)(g)	(c)(d)	Ref	(e)(s)	(b)(g)	(c)(d)
Q9401	5.1	5.7	8.9	Q9408	4.3	3.6	0
Q9402	3.4	4.3	5.1	Q9409	4.4	5.1	8.9
Q9403	4.4	5.1	8.9	Q9410	4.3	3.6	0
Q9404	4.3	3.6	0	Q9411	4.3	3.6	0
Q9405	4.4	5.1	8.9	Q9412	135.1	1.4-6	70.5
Q9406	4.3	3.6	0	Q9413	0.3	0.9	70.5
Q9407	4.4	5.1	8.9	Q9414	6.6	5.9	2.4

~ VM Board Waveforms ~

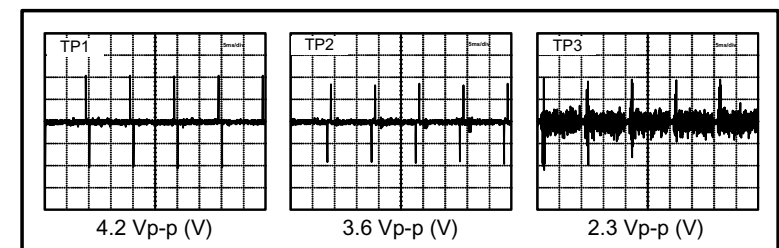

A B C D E F G H I J K L M N

1
2
3
4
5
6
7
8
9
10
11

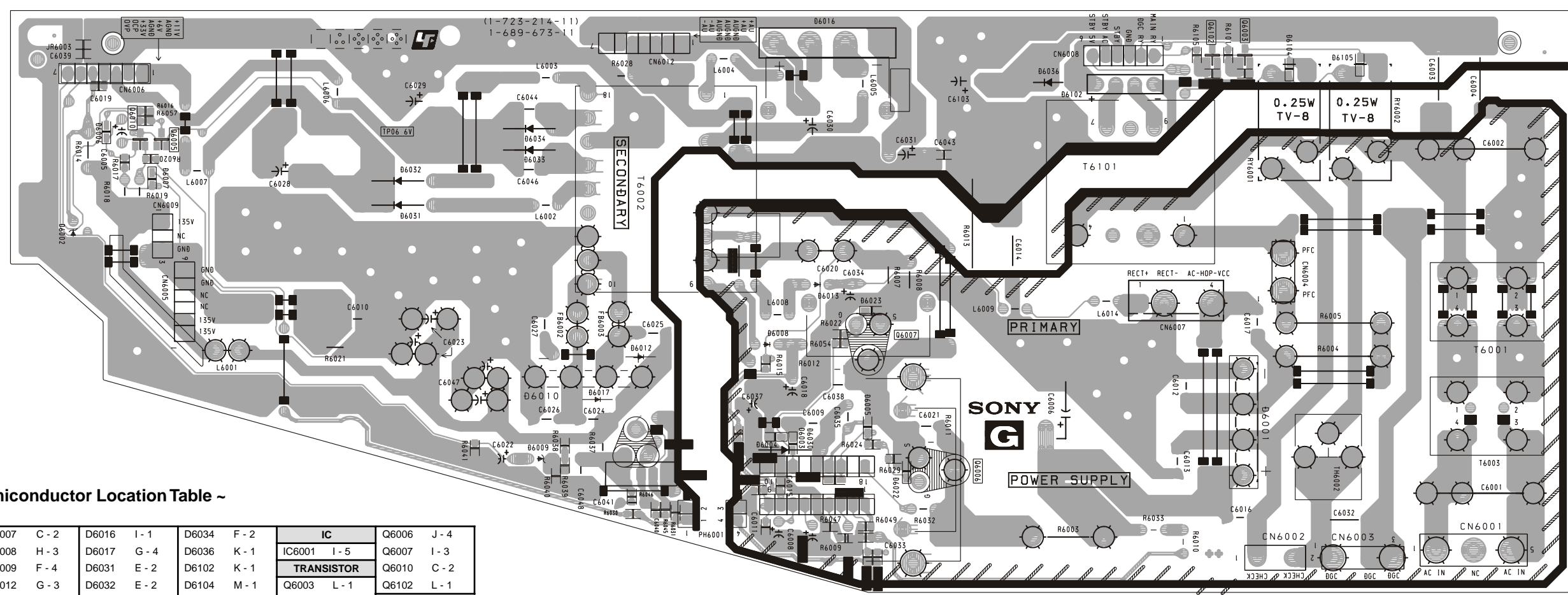

~ G Board Semiconductor Location Table ~

DIODE	D6007 C - 2	D6016 I - 1	D6034 F - 2	IC	Q6006 J - 4
D6001 L - 4	D6008 H - 3	D6017 G - 4	D6036 K - 1	IC6001 I - 5	Q6007 I - 3
D6002 B - 3	D6009 F - 4	D6031 E - 2	D6102 K - 1	TRANSISTOR	Q6010 C - 2
D6004 H - 4	D6012 G - 3	D6032 E - 2	D6104 M - 1	Q6003 L - 1	Q6102 L - 1
D6006 C - 2	D6013 I - 3	D6033 F - 2	D6105 M - 1	Q6005 C - 2	

~ G Printed Wiring Board Conductor side ~

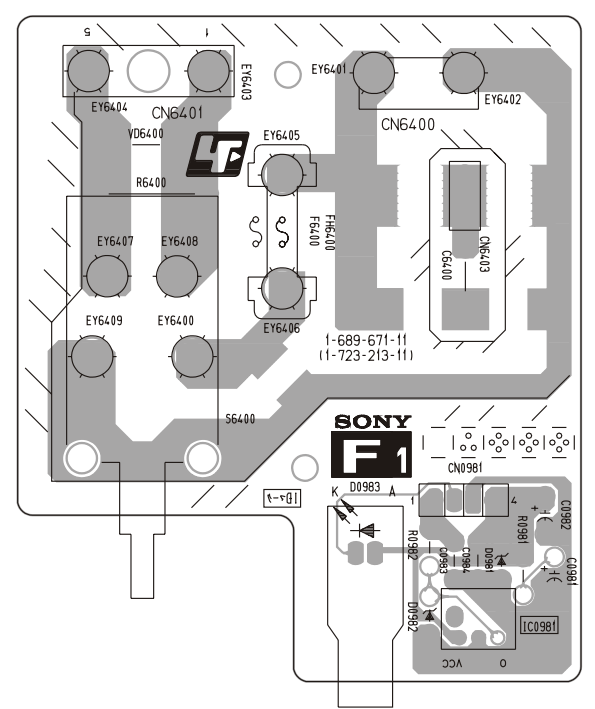

~ F1 Printed Wiring Board Conductor side ~

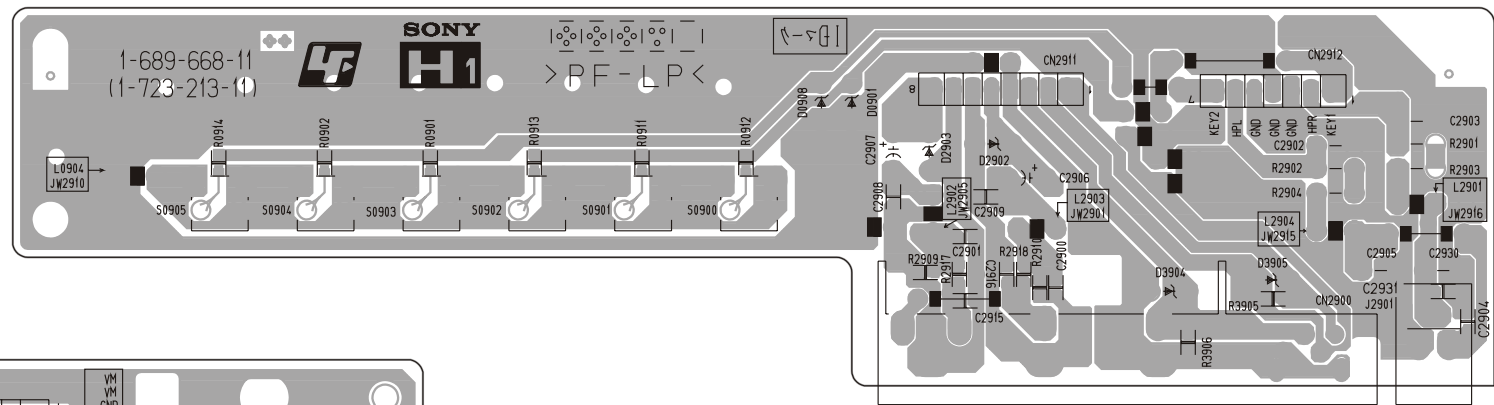

~ H1 Printed Wiring Board Conductor side ~

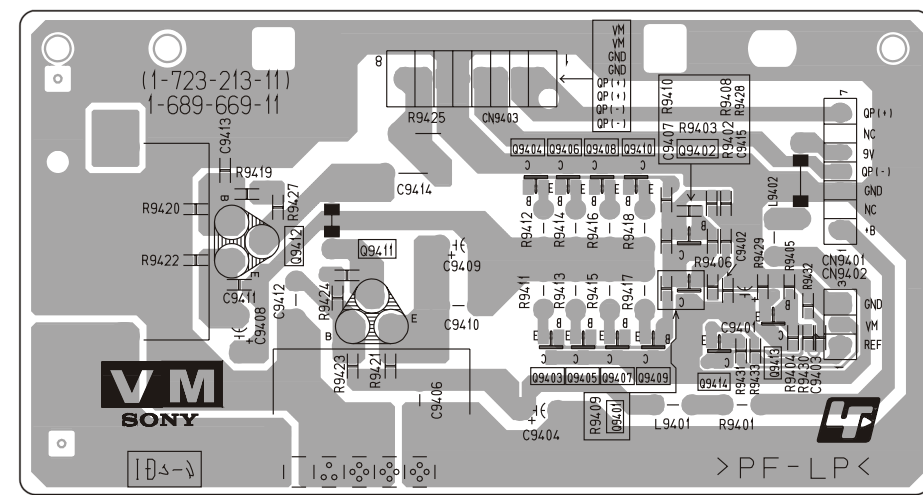

~ VM Printed Wiring Board Conductor side ~

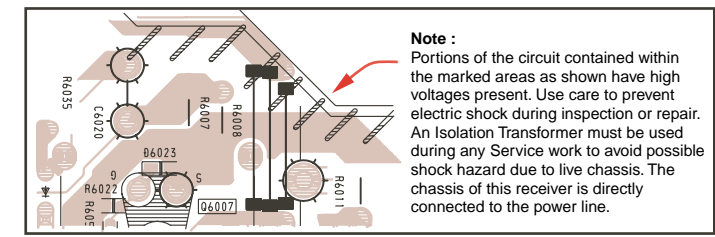

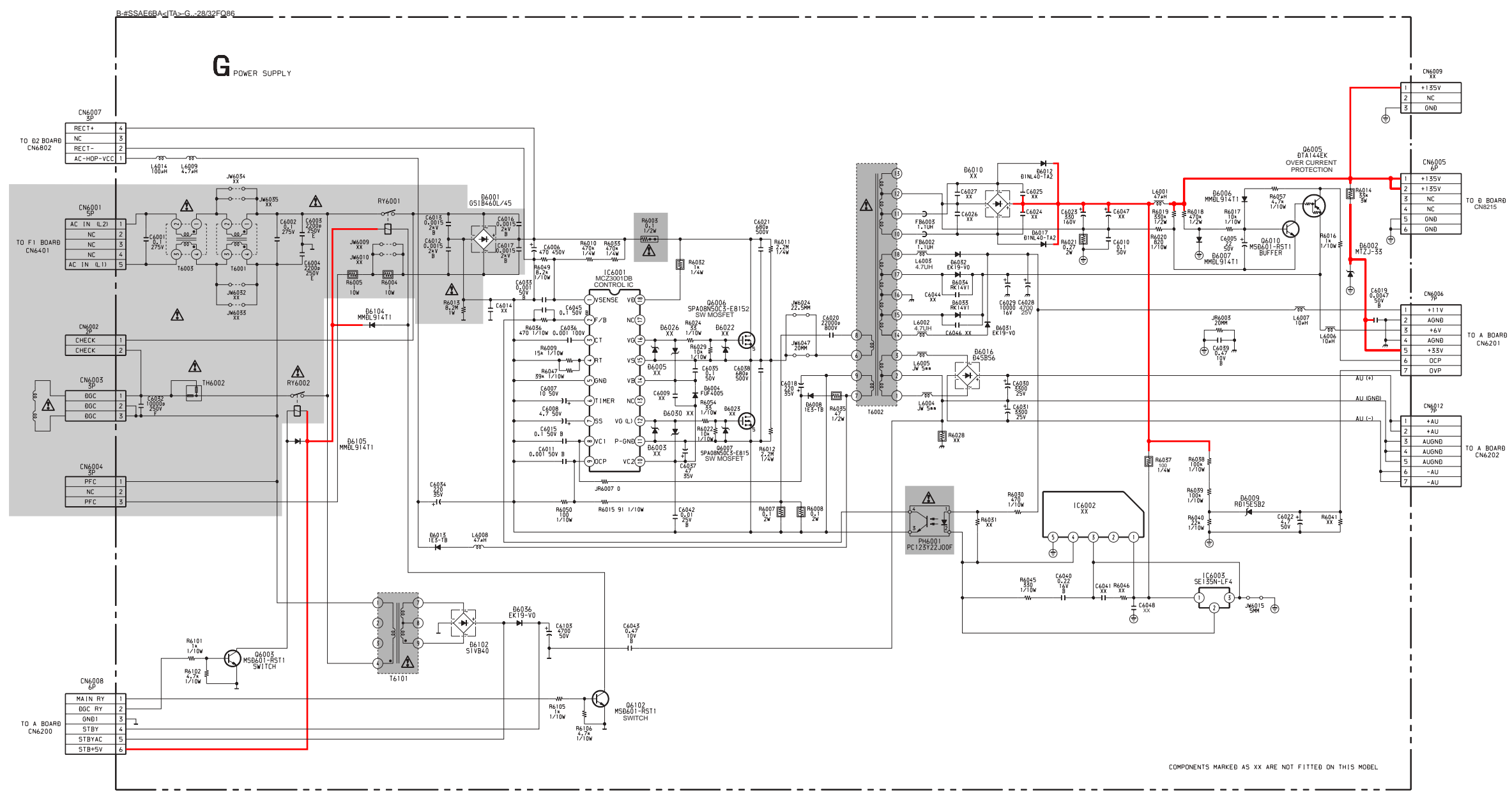

~ G Board Schematic Diagram [Power Supply] ~

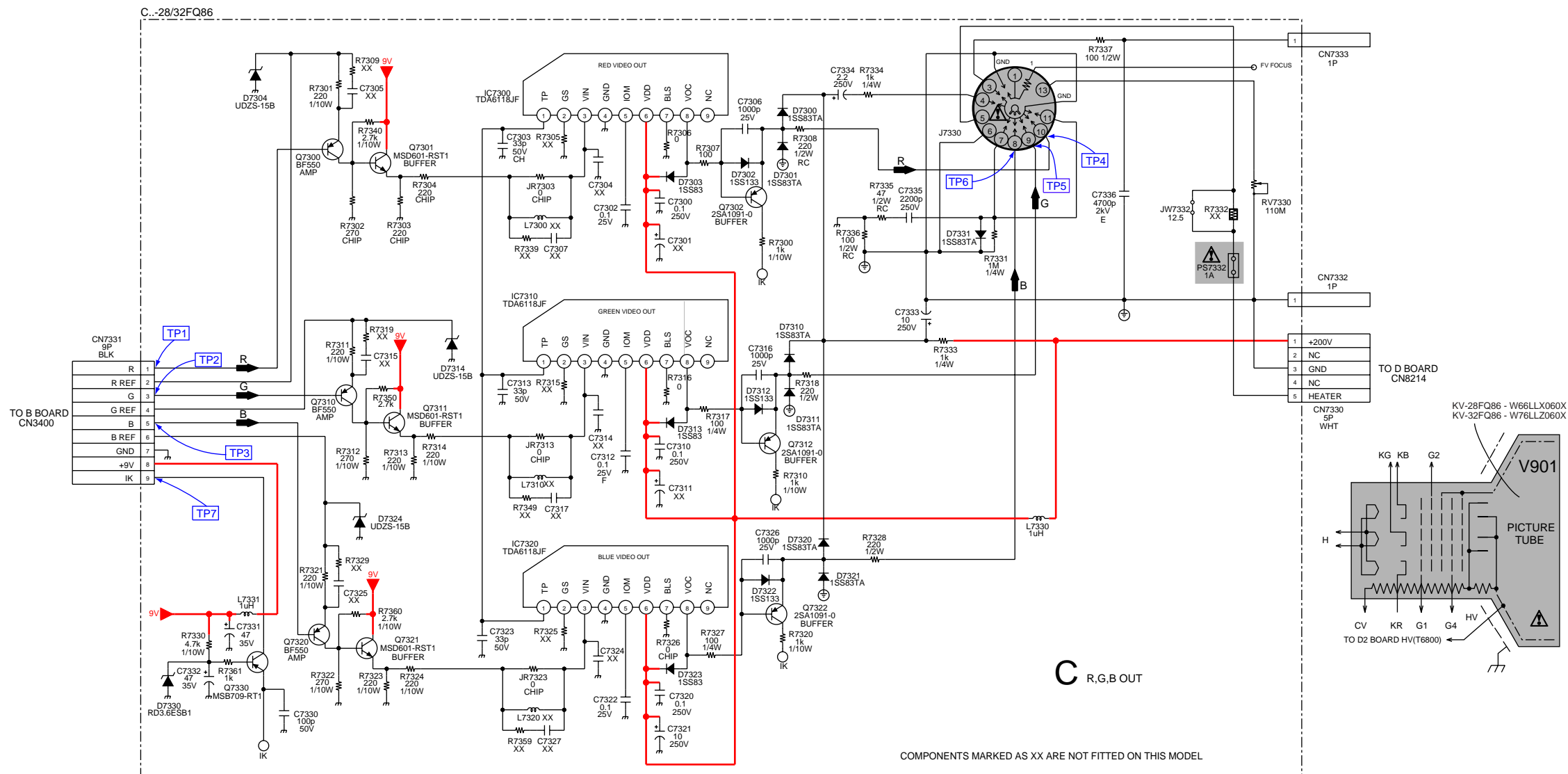

C R,G,B OUT

~ C Board Schematic Diagram [R-G-B Out] ~

~ C Printed Wiring Board Conductor side ~

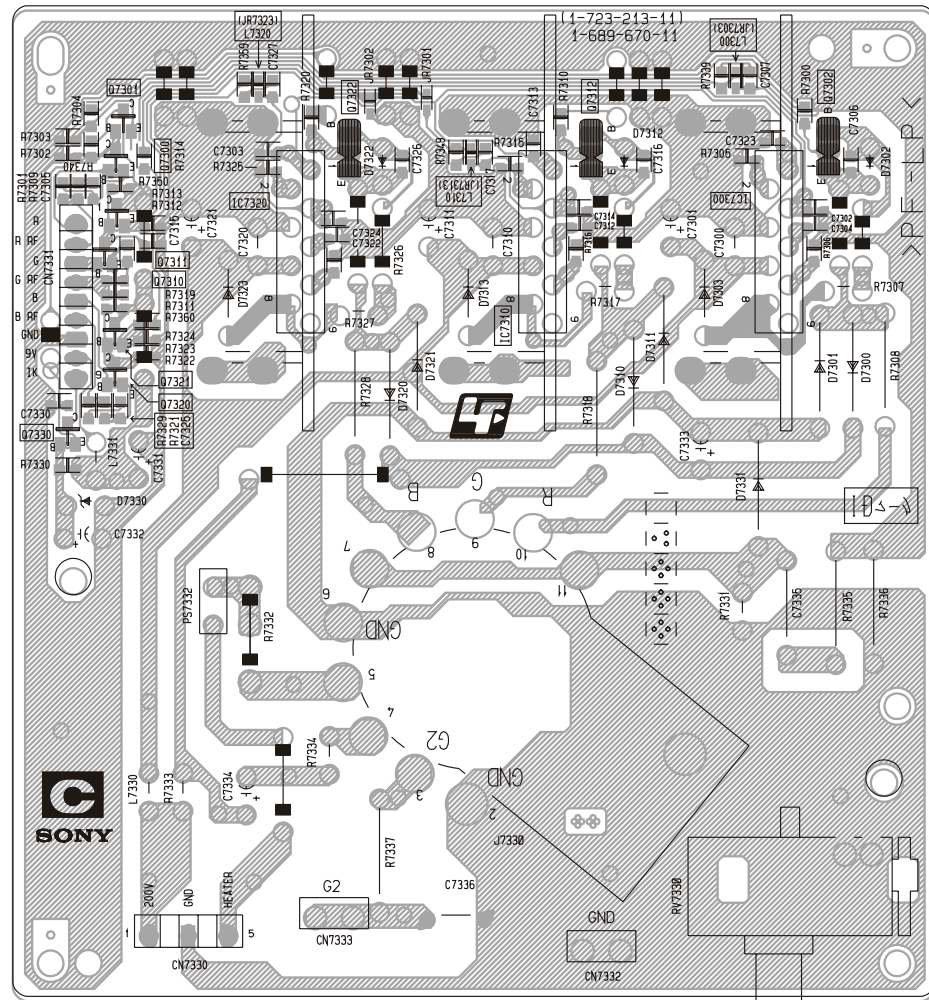

~ C Board Waveforms ~

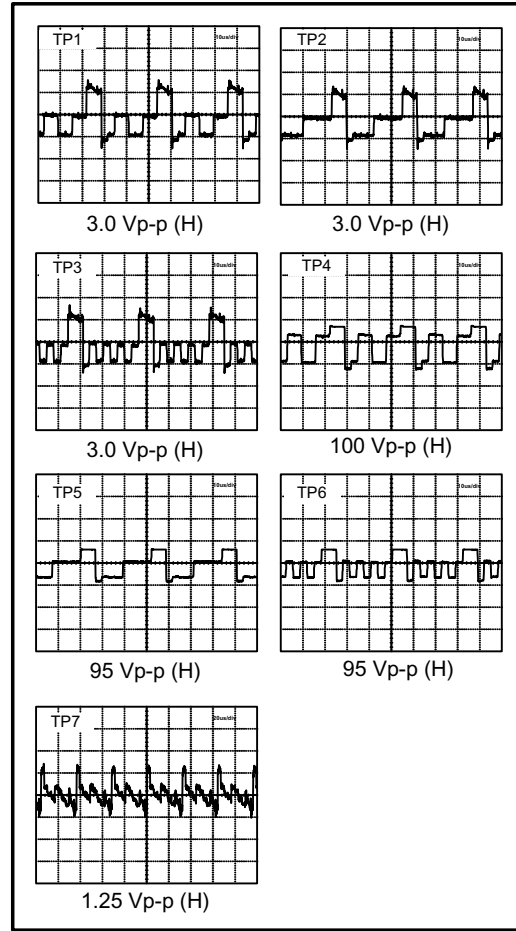

~ J Printed Wiring Board Conductor side A ~

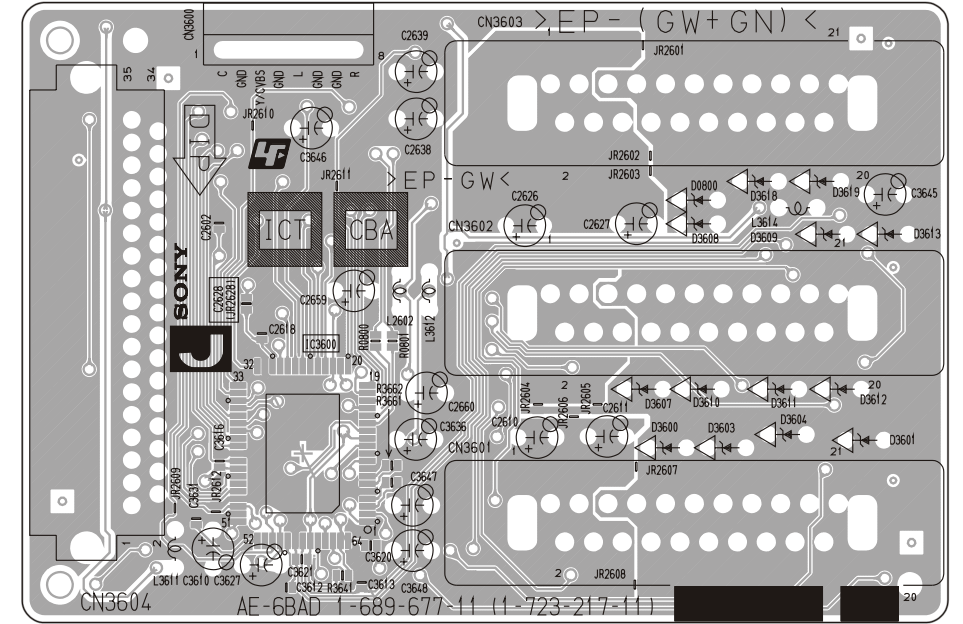

~ C Board Semiconductor Voltage Table ~

Ref	(e)(s)	(b)(g)	(c)(d)	Ref	(e)(s)	(b)(g)	(c)(d)
Q7300	7.5	6.9	2.4	Q7312	149.5	149.56	3.8
Q7301	1.8	2.4	8.9	Q7320	7.6	6.9	2.3
Q7302	145.9	147.8	4.0	Q7321	1.7	2.3	8.9
Q7310	7.6	7.0	2.2	Q7322	148.4	150.6	3.8
Q7311	1.6	2.2	8.9	Q7330	3.6	3.2	0

~ C Board IC Voltage Table ~

IC Voltage Table			
Ref No	Pin No	Voltage (V)	
IC7300	1	5.3	
	2	21.9	
	3	1.9	
	5	5.9	
	6	205.4	
IC7310	1	5.1	
	2	0	
	3	1.7	
	5	5.6	
IC7320	6	205.4	
	8	149.5	
	IC7320	1	5.1
		2	0
3		1.8	
5		4.8	
6		205.4	
8	150.4		

~ J Printed Wiring Board Conductor side B ~

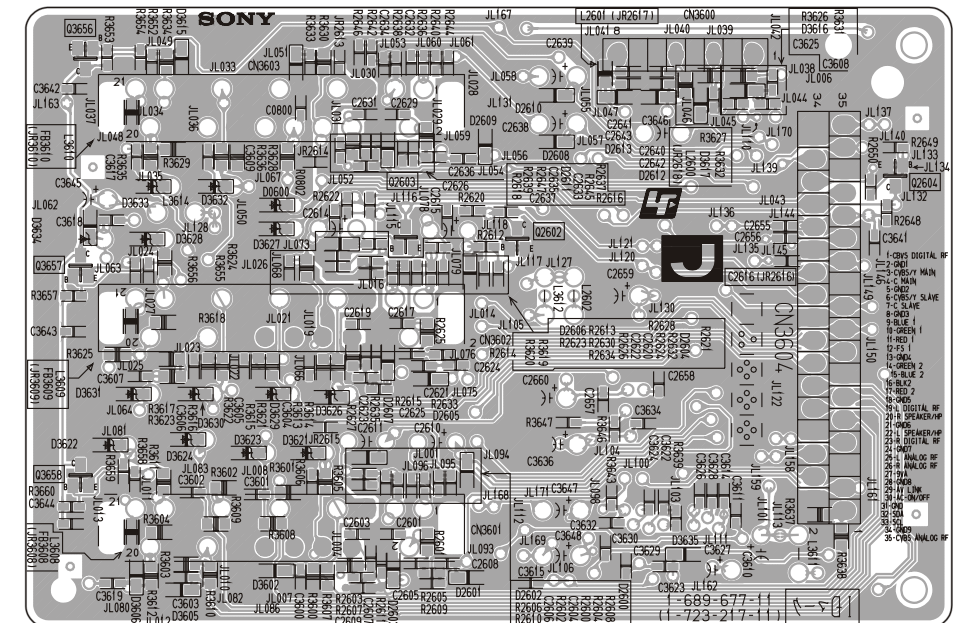

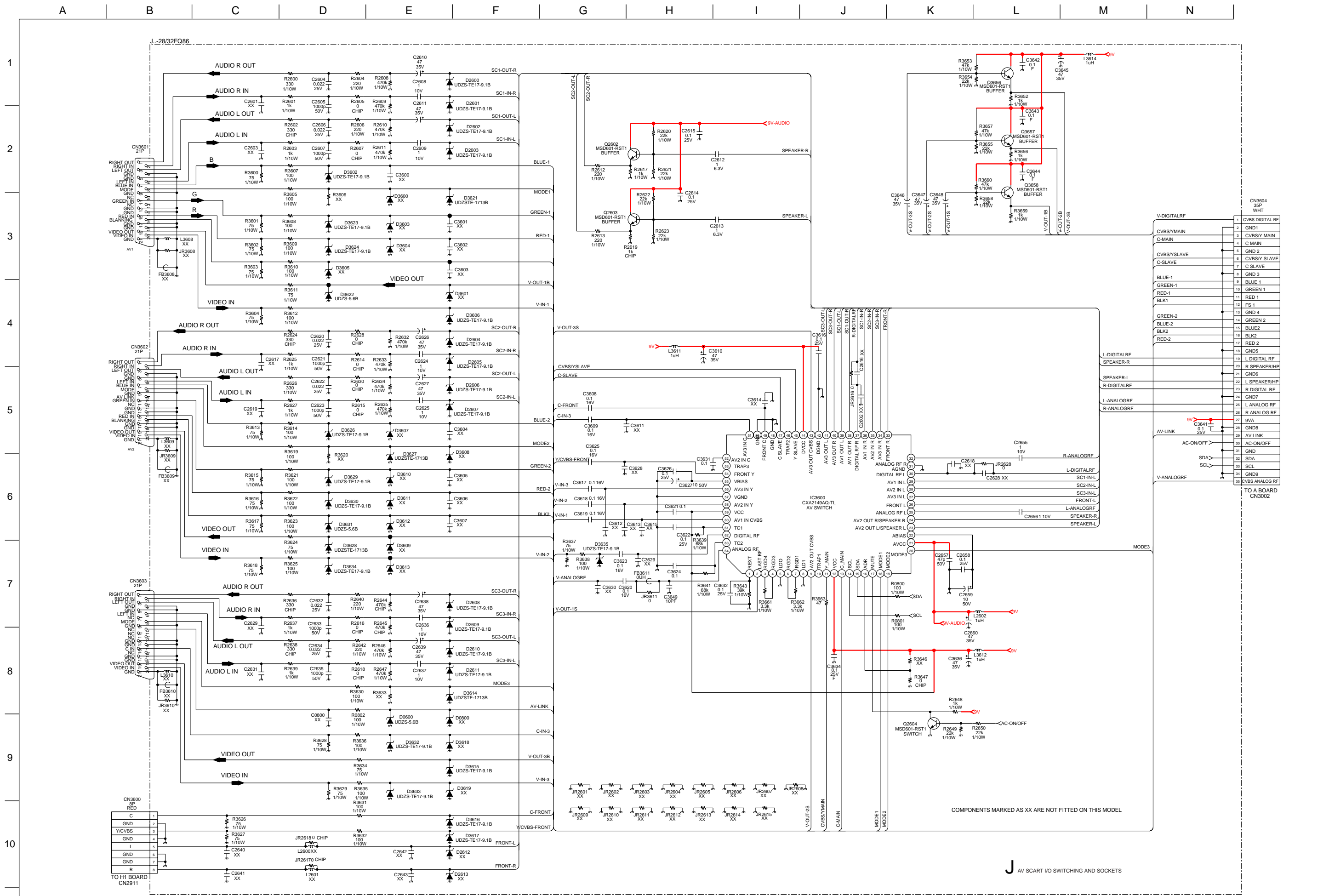

C	1	R3626	75	1/10W					
GND	2								
Y/ CVBS	3	R3627	75	1/10W	JR2618 0 CHIP				
GND	4								
L	5	C2640	XX						
GND	6								
GND	7								
R	8	C2641	XX		JR26170 CHIP				

1	CVBS DIGITAL RF
2	GND1
3	CVBS Y MAIN
4	C MAIN
5	CVBS Y SLAVE
6	CVBS Y SLAVE
7	C SLAVE
8	GND3
9	BLUE 1
10	GREEN 1
11	RED 1
12	FS 1
13	GND 4
14	GREEN 2
15	BLUE 2
16	BLK 2
17	RED 2
18	GND 5
19	L DIGITAL RF
20	R SPEAKER/RHP
21	GND 6
22	L SPEAKER/RHP
23	R DIGITAL RF
24	GND 7
25	L ANALOG RF
26	R ANALOG RF
27	AV A
28	GND 8
29	AV LINK
30	AC-ON/OFF
31	GND
32	SDA
33	SCL
34	GND 9
35	CVBS ANALOG RF

~ J Board Schematic Diagram [AV Scart I/O Switching and Sockets] ~

~ D Printed Wiring Board Conductor side ~

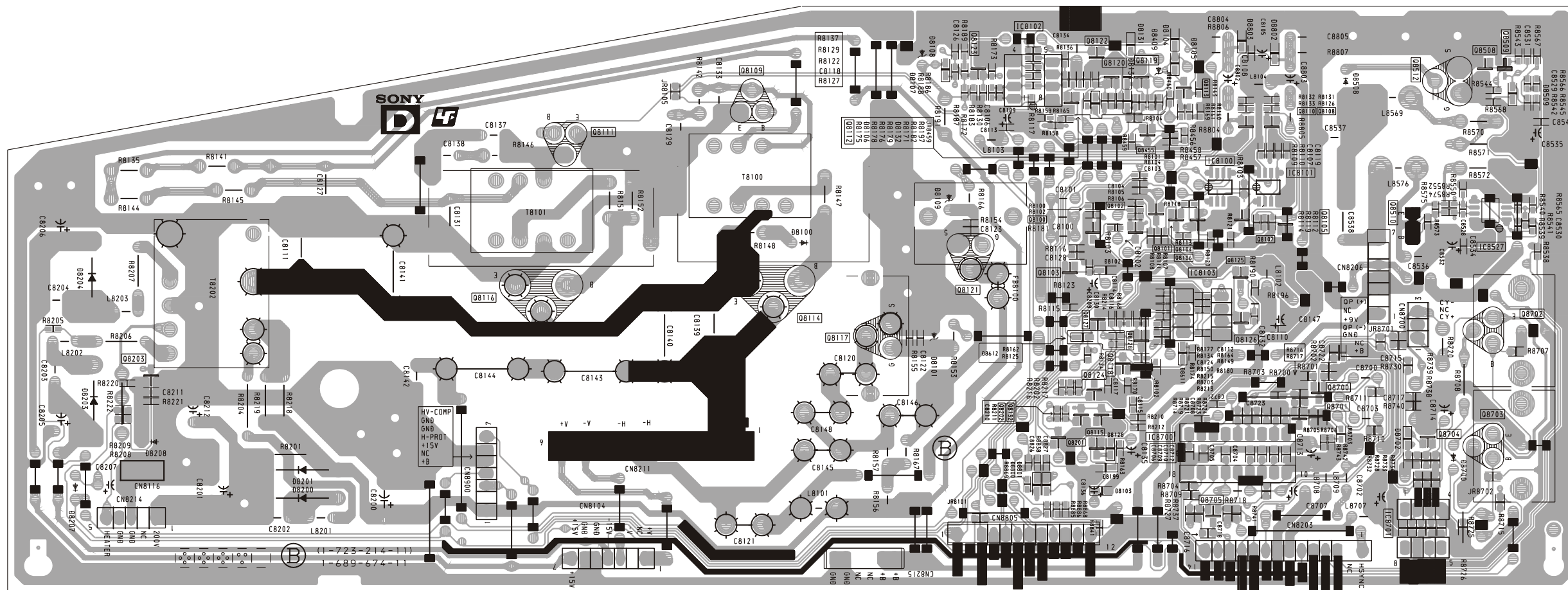

~ D Board Waveforms ~

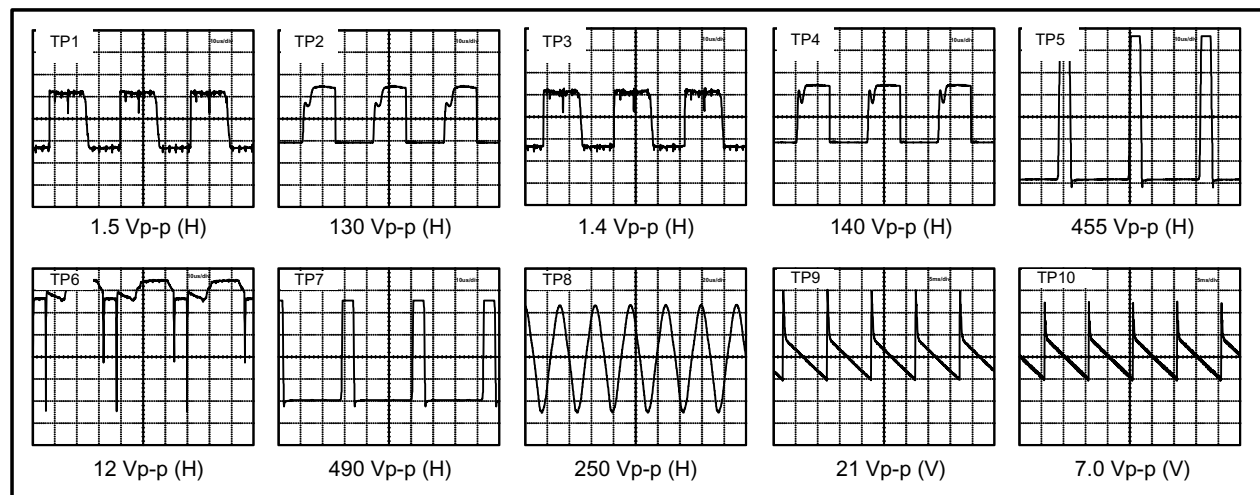

~ D Board IC Voltage Table ~

IC Voltage Table			IC Voltage Table		
Ref No	Pin No	Voltage (V)	Ref No	Pin No	Voltage (V)
IC8100	1	0.3	IC8102	1	3.8
	2	3.9		2	0.4
	3	3.9		3	0.4
	5	3.9		5	0.4
	6	3.6		6	0.4
	7	0.4		7	0.4
	IC8101	1		0.3	IC8103
2		3.9	2	1.7	
3		3.2	3	1.7	
5		3.2	5	0.9	
6		3.6	6	3.6	
7		3.5	7	1.1	

~ D Board Semiconductor Voltage Table ~

Ref	(e)(s)	(b)(g)	(c)(d)	Ref	(e)(s)	(b)(g)	(c)(d)	Ref	(e)(s)	(b)(g)	(c)(d)
Q8100	0	0	3.0	Q8110	2.4	3.7	0	Q8125	1.2	1.1	8.9
Q8101	0	0	3.9	Q8111	0	0	62.9	Q8126	1.2	1.1	0
Q8102	0	1.0	3.6	Q8113	0.4	0	8.9	Q8127	1.1	1.5	0
Q8103	3.9	0	8.9	Q8115	8.6	8.9	0	Q8128	3.4	1.5	8.9
Q8104	0	0.3	3.7	Q8118	0	0	3.6	Q8132	0	0	3.6
Q8105	0	3.5	0.3	Q8119	1.2	0.5	0	Q8201	0	0.6	3.7
Q8106	0	0.3	3.9	Q8120	1.3	0.5	0	Q8202	0	0.9	3.7
Q8107	0	0.3	3.9	Q8121	0	1.2	135.2	Q8455	1.2	1.7	8.9
Q8108	2.4	0.3	0	Q8122	0.5	1.4	0	Q8510	8.1	7.5	0.4
Q8109	0	0	58.0	Q8123	0.5	1.3	0	Q8512	0	5.3	32.6

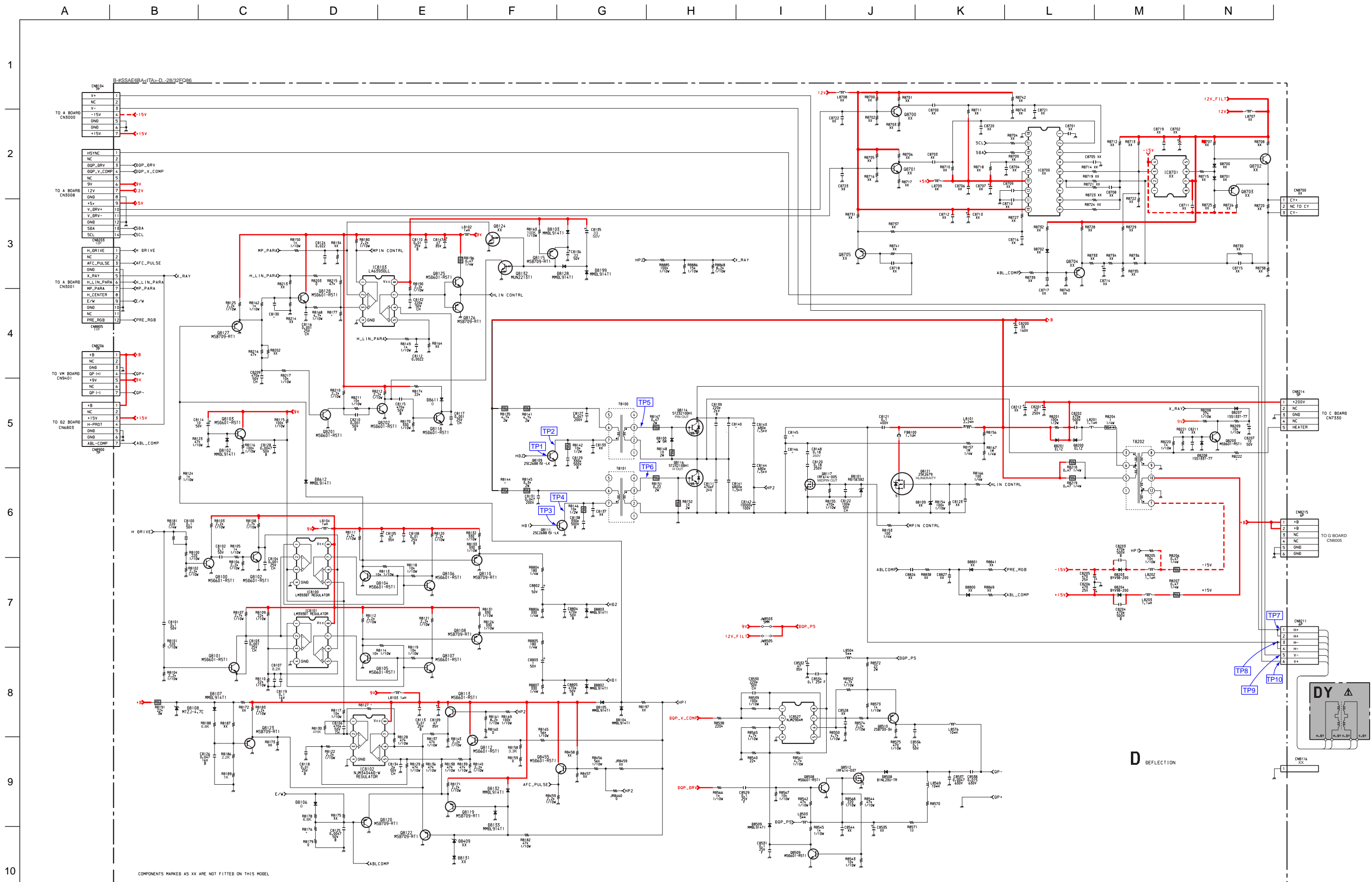

~ D Board Schematic Diagram [Deflection] ~

5-4. SEMICONDUCTORS

1E3
1SS133T-77
1SS83
D1NL20U
D1NL20U-TR
D1NL40-TA2
EL1Z
ERA22-08
GP08D
FUF4005
HZS9.1NB2
MTZJ-33B
MTZJ-4.7C

RD15ES-B2
RD39ES-B2
RD3.6ES-B2
RD5.6ESB2
RK14V1

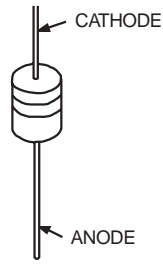

BYV98-200-RAS 15/12

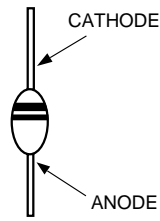

L7809CV/LSY
STP5NK40Z(033Y)
ST2310DHI

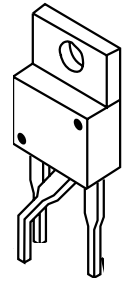

CA0005AD
LA6393DLL

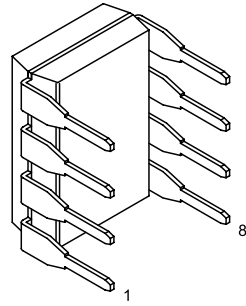

LA6500-FA

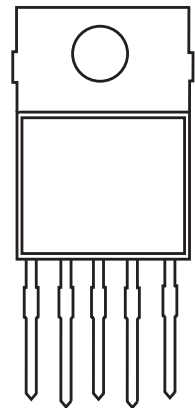

1PS184-115
MM3Z4V7T1
MM3Z6V8T1
MM3Z9V1ST1
MM3Z15VT1
MMDL914T1
UDZSTE-1713B
UDZSTE-1718B
UDZSTE-173.9B
UDZSTE-175.6B
UDZSTE-176.2B
UDZSTE-179.1B
UDZSTE-17-7.5B

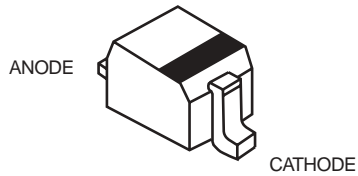

CXA2019AQ-TL
CXA2149AQ-TL

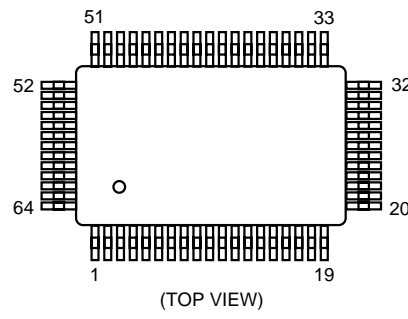

LM393DT
LM358N

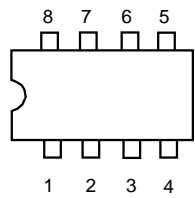

2SA1091-O

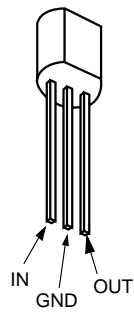

CXD3804R-T6

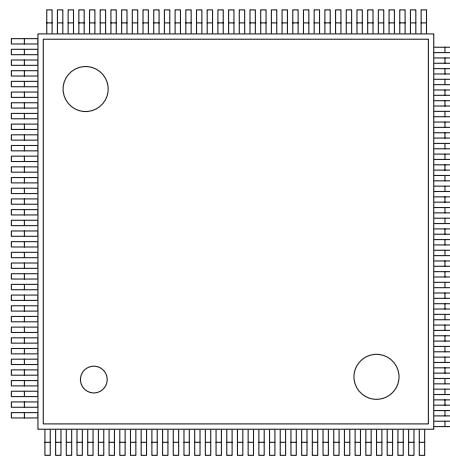

M24C32-WMN6T(A)
SN74LV00APWR
TDA2822D013TR

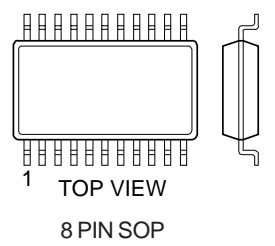

2SB734-34

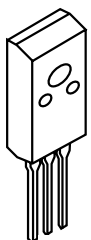

2SC2688(5)-LK

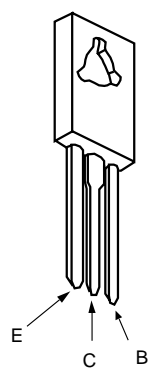

D4SBS6
S1VB40

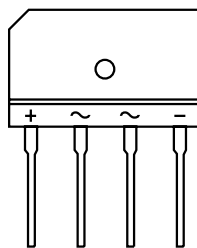

MSP3411G-QA-B11

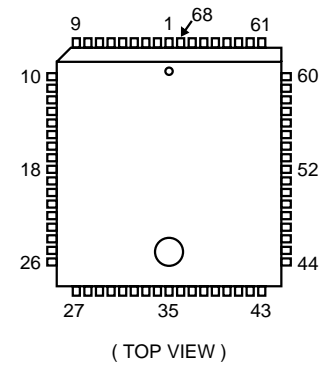

2SK2036(TE85L)
2SA1037AK-T146
DTA144EK
DTA144EKA-T146
DTC144EKA
MSB709-RT1
MSD601-RST1
M1MA152WA-T1
UN2111

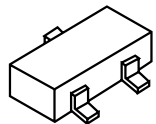

D2S4MF

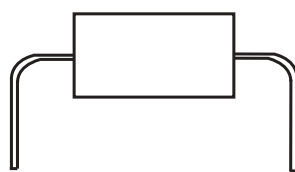

NJM290M

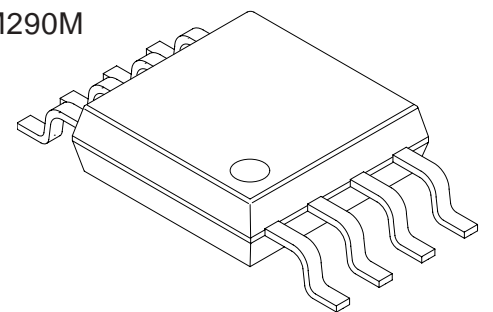

BA033T
IRF614-005
IRF614-037
IRF620
2SA2005
2SC5511

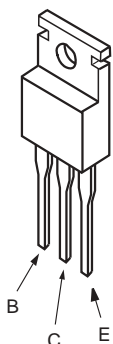

GS1B460/45

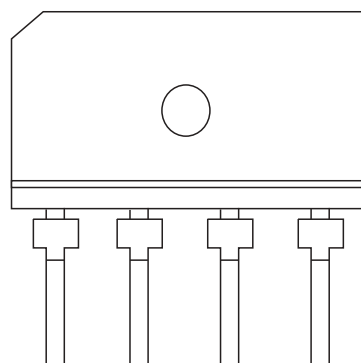

NJM3404AD-W
UPC4558G2

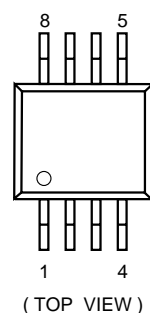

PQ1CG2032FZ

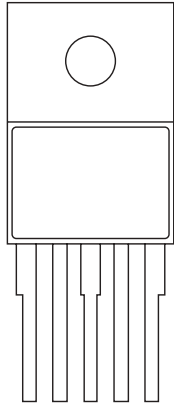

UPC1093J-1-T

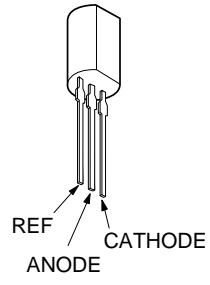

PST9143NL

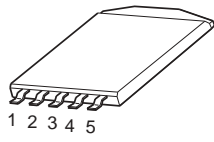

VSP9417BC3G

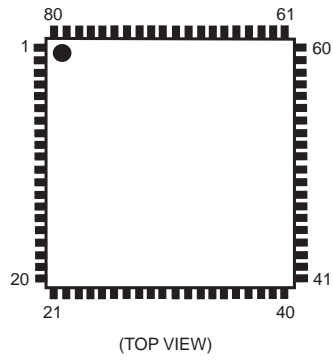

SE135N-LF4

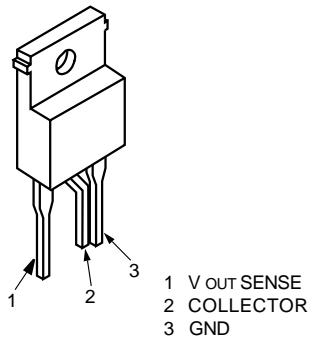

STV9379

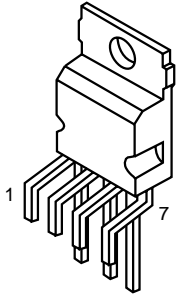

TDA7482
TDA7269

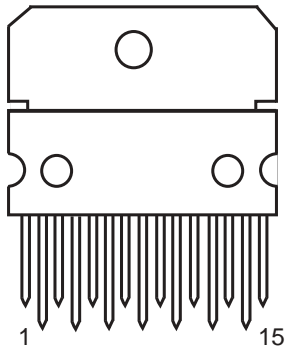

TLHK5190

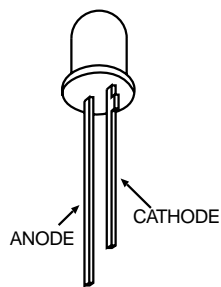

TL1431CZ-AP

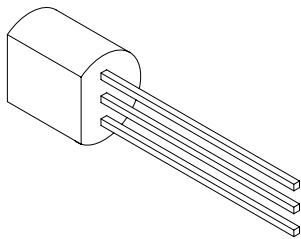

5-5. IC BLOCK DIAGRAMS

A BOARD IC5400 STV9379A

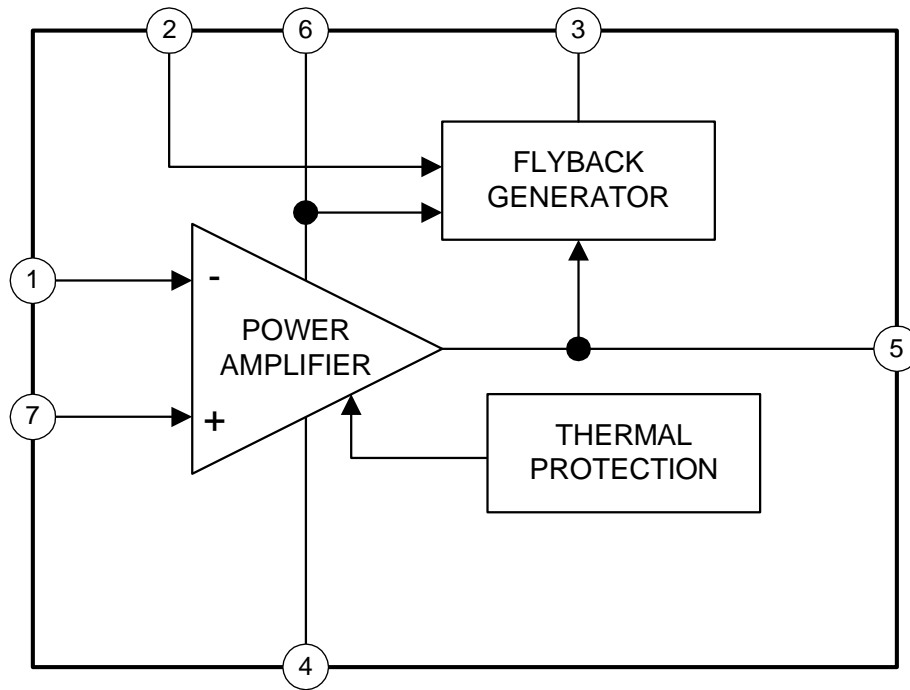

G BOARD IC6001 MCZ3001D

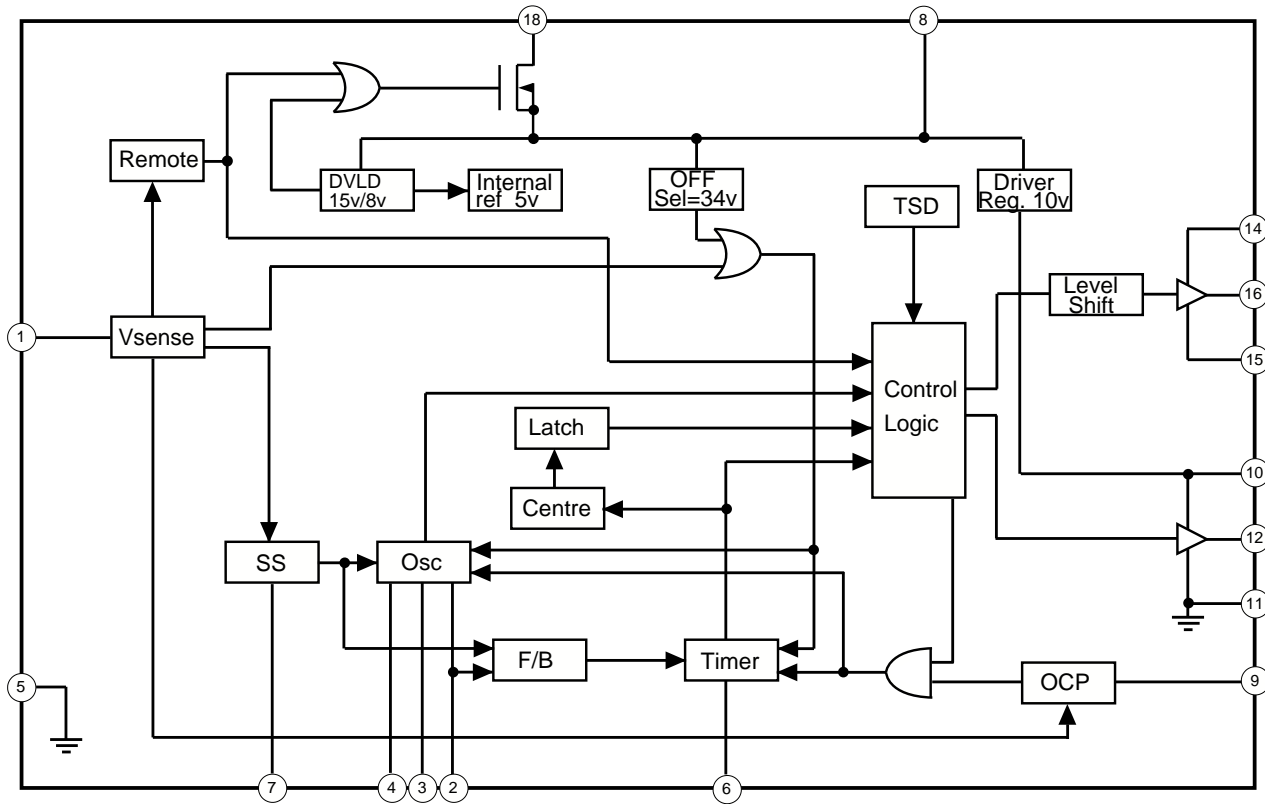

A BOARD IC6210 BA033T

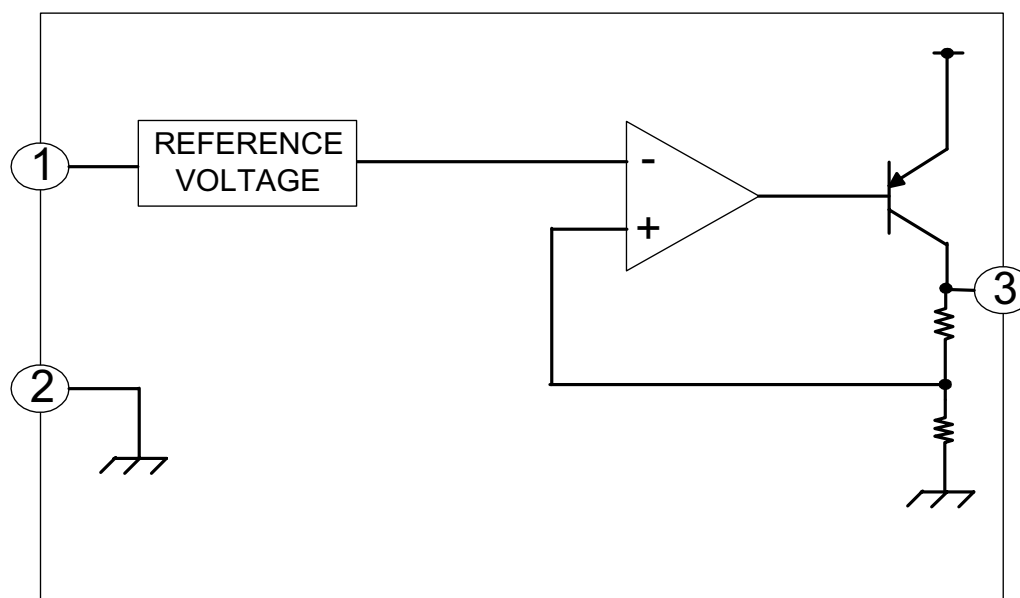

A BOARD IC2000 MSP3411G

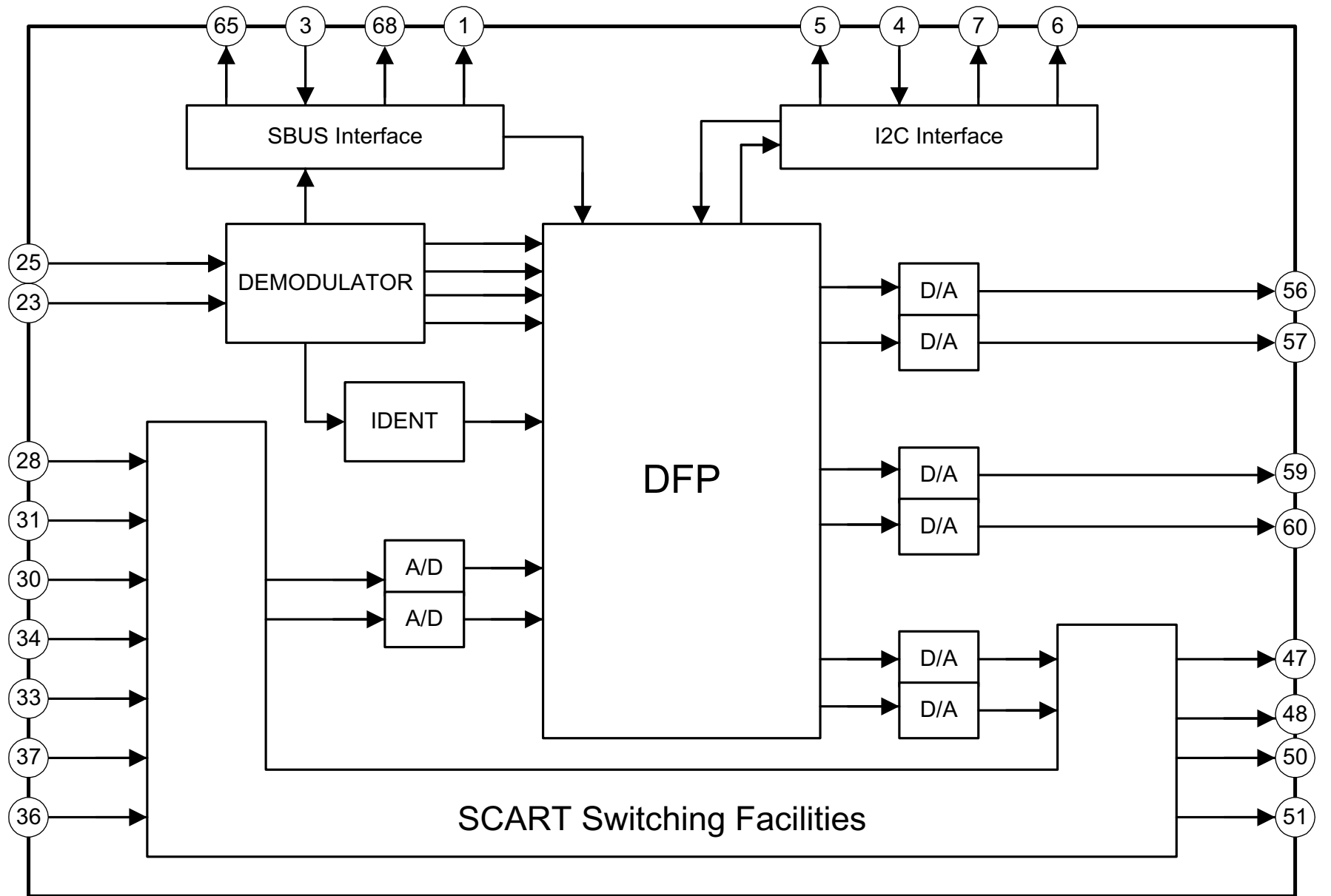

G BOARD IC6003 SE135N-LF4

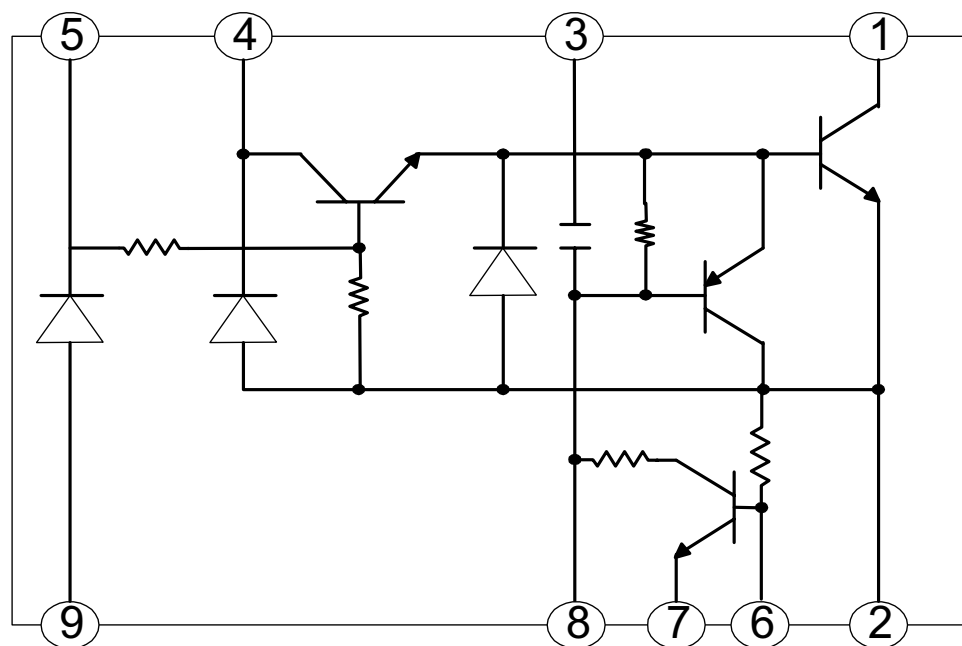

D64E:@? ' 6 I A=@565 G:6 HD

?@E6 +

- Hsd l r vhsq mn o`qs mt l adq `mc mn cdrbqhosnm `qd mns rsnbjdc adb` trd sgdx `qd rdken l qdpthqdc enq qntshmd rdquhbd-
- Sgd bnmrsqt bshnm o`qsr ne `m `rrd l akdc o`qs `qd hmchb` sdc vhsq `bnkk`shnm mt l adq hm sgd qd l `qjr bnkt l m-
- Hsd l r l`qjdc @), `qd mns rsnbjdc rhmbd sgdx `qd rdken l qdpthqdc enq qntshmd rdquhbd- Rn l d cdk`x rgntkc ad `mshbho` sdc v gdm nqcdqhm f sgd rrd hsd l r-

'†"Ž 492DD:D

Note : Les composants identifiés par une trame et par une marque Δ sont d'une importance critique pour la sécurité. Ne les remplacer que par des pièces du numéro spécifié.

Note : The components identified by shading and marked Δ are critical for safety. Replace only with the part numbers specified in the parts list.

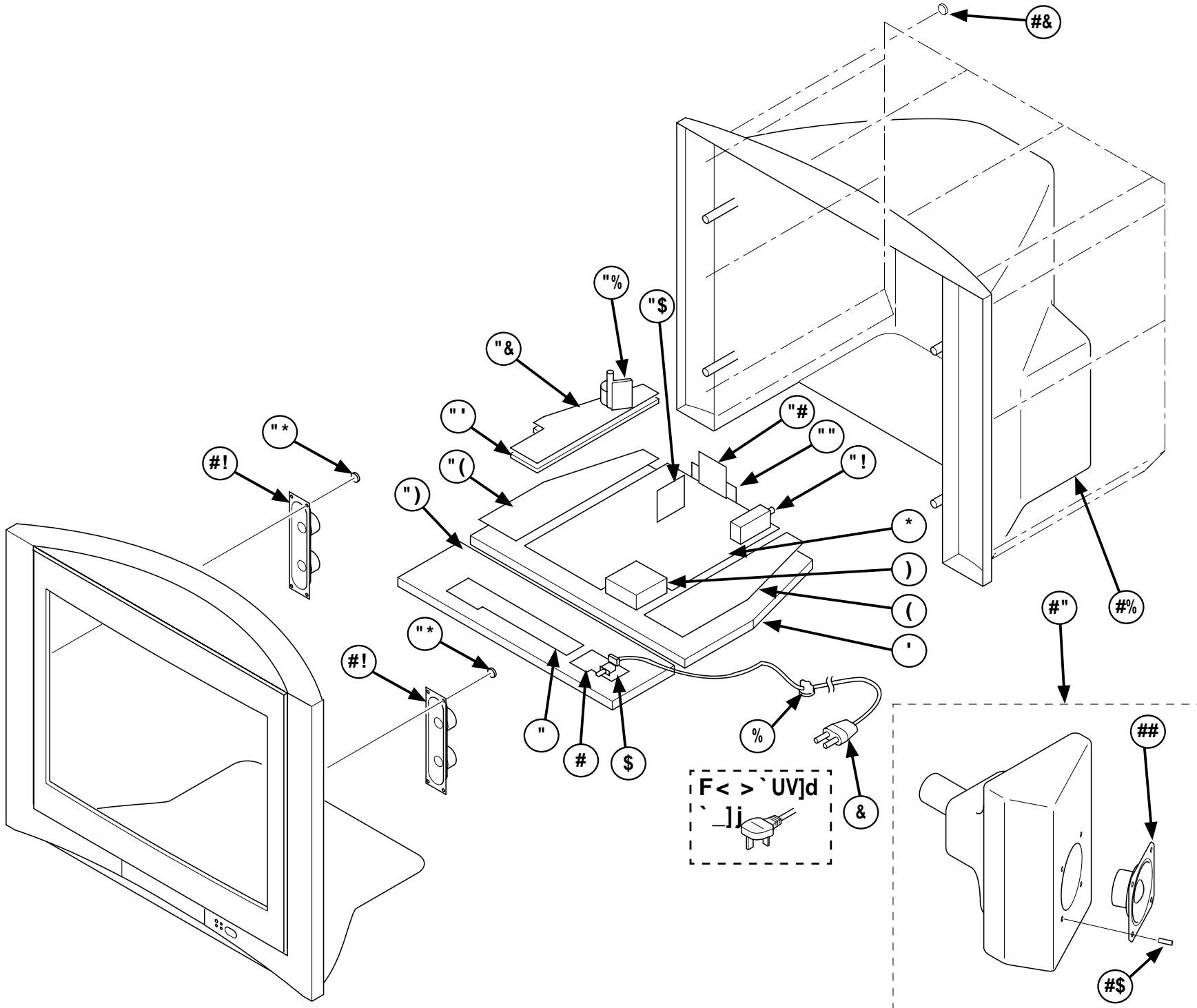

C67Z@	A2CFZ@	5DCAE@	C6>Z<	C67Z@	A2CFZ@	5DCAE@	C6>Z<
"	fz "%&!*"2	9 3025 4@A66		"%	"1%8\$ \$)1#	E2D7C>C 2DL 7-J32k 1?1! #žK#%	
#	fz "%&'""12	7 3025 4@A66					1<G # 7B' /
\$	"1&"1%\$ #	DHE4L AFD 1 24 A@67			"1%8\$ %%% #	E2D7C>C 2DL 7-J32k 1?1! #žK#%	1<G \$7B' /
%	fz # # 8\$!"	24 405 =@< 1D4		"&	fz "\$ # 8@12	5# 3025 4@A66 <G # 7B'	
&	fz () \$!) \$""	405L A@6C 1HE9 7-FC			fz "\$ # 8@12	5# 3025 4@A66 <G \$7B'	
'	fz !* & (\$! #	3246L >2?		"	fz !* & (\$!"	3246L 5#	
(2 "\$ # * \$2	8 3025 4@A66		"(fz "\$ # * %2	5 3025 4@A66 <G # 7B'	
)	"1%&1&!!"	4@-L 406 %ž&>9		"	fz "\$ # * ("12	5 3025 4@A66 <G \$7B'	
*	fz "\$ # * "12	2 3025 4@A66 1<G # 7B' 3<G \$7B' 3		"	fz !* \$) * 1""	3246L 9	
	fz "\$ # * #2	2 3025 4@A66 1<G # 7B' 6<G \$7B' 6<		"*	%! &!) (!!"	D0G-H1% "/H0/AE2A?8	
	fz "\$ # * (#2	2 3025 4@A66 1<G \$7B' F'		#	"1%)1""	D02-6C1%ž # #4/	
!")1&)1!"	70@E5 3E7F "" 1<G \$7B' F'		#	fz "" ! \$!) %2	H07C 4@A66 2D ## #8	
)1&)1&\$1!"	70@E5 3E76%" 1<G # 7B' E		##	"1%(1""	D02-6C1) 4/	
)1&)1&\$ #	70@E5 3E76%" 1<G # 7B' 3<G \$7B' 3		#\$	(') & ' \$ ("	D0G-H03EA %" EJA# : E \$	
""	fz !!"!)!"1!"	DFA@EGL ;		#%	%! * \$) #1""	C6C 406C1<G # 7B' /	
"#	fz "%&' # \$2	; 3025 4@A66			%! * \$) * 1\$	C6C 406C1<G \$7B' /	
"\$	fz "\$ # * &2	3 3025 4@A66		#&	(') & %) (*	D0G-H03EA \$ "# EJA# : E \$	

'!# A:4EFC6 EF36

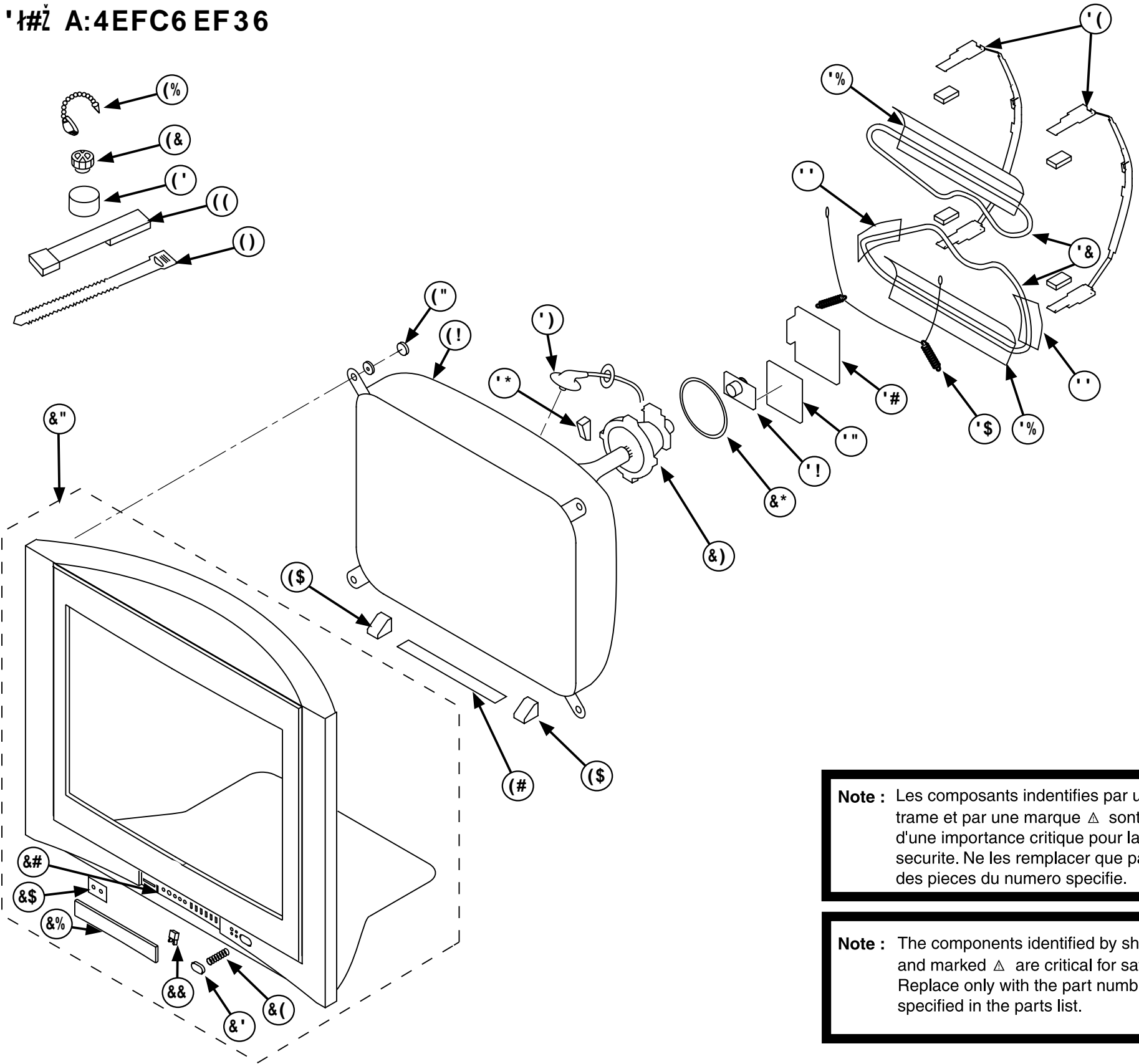

Note : Les composants indentifiés par une trame et par une marque Δ sont d'une importance critique pour la securite. Ne les remplacer que par des pieces du numero specifie.

Note : The components identified by shading and marked Δ are critical for safety. Replace only with the part numbers specified in the parts list.

C672@	A2CF2@	5D1CAE@	C6>2<	C672@	A2CF2@	5D1CAE@	C6>2<
&	I!%&")!)"	3K7E 2D <G# 7B' 36	&# &	' &	"!%#&))!)"	4@-L 588HD 781<G# 7B' /	
	I!%&")%)"	3K7E 2D <G\$#7B' 36<	&# &	'	"!%#&))!)"	4@-L 588HD 781<G\$#7B' /	
	I!%&!\$%#"	3K7E 2D <G\$#7B' F	&# &	"	f!b\$*# &#&#"	4D @L 581<G\$#7B' /	
#	f!b!) (I&S!"	>F-E 3HR@		' (f!b#%)"#!"#	9@56L 581#&/ 1<G# 7B' /	
&	%!) (I&S!"	8F 5L = 8E		' (f!b#%)"!!"#	9@56L 581#&/ 1<G\$#7B' /	
&	%!*\$)#!!"	5@C1<G# 7B' /		')	"!#&!%&!"	4A 2DL 9 81 @E2861<G\$#7B' /	
	%!*\$)*(!!"	5@C1<G\$#7B' /		'	"!#&!%&!"#	4A 2DL 9 81 @E2861<G# 7B' /	
&	%!)&&(!!"	DC 78 5@C		' *	\$(!%&&!\$	D246L 5J	
&	%!) (I&S!"	A@C 3HR@		' (!)! (S&!*"!&	A 4FC6 EF361H' =I' !/ <G# 7B' /	
&	%#%#%!"	DC 78		')! (S&!*"!&	A 4FC6 EF361H' =K' !/ <G\$#7B' /	
&)!%&!&!"	557-6E @ J@61J#CC#=# 1<G# 7B' /		"	%!%!('&#"	DCGL E2A 78 (f!C@? H29C	
'	"!%&!%!"	557-6E @ J@61J\$#C# 1<G\$#7B' /		(#	%#%'"!"	D66L 3@E 78	
&	"!%*!\$!"	4@-L 72 @E@		(S	f!b#!"!"!"	DFA@E 4E1<G# 7B' /	
'!)!%&!"!"	76k 2DL1?2#*1>		'	f!b!) (I&S!"	DFA@E 4E1<G\$#7B' /	
"	f! "%&' #!2	G> 3@C1 4@A66		(%	%\$!) (!!"	4= A =65 HC6	
' #	f! "%&' !!"	4 3@C1 4@A66		(&	"!%&!%&!"	>286L @E2861<G\$#7B' /	
' \$	%\$*!\$)"#	DC 78 E6D@		('	"!%&!%&!"	>286L 5D; "!">> E	
' %	f!b# \$ \$!"	4D @L 581<G# 7B' /		((I!%& (!#%"	AGC-2=@L 4@C6E @	
	f!b!*&&\$!"	4D @L 581<G\$#7B' /		()	\$(!!"! (!!"	325L 3 75 78	

6Z@ ARCE@ 5DCAE@ 6-2<

fi 2! "\$!#&%(!2 5# 3`RcU 4` ^ a]VeV <G#)7B)'
fi 2! "\$!#&%*!2 5# 3`RcU 4` ^ a]VeV <G!\$#7B)'

5# 3`RcU 4` ^ ^ ` _ ARced

\$("!)&!)!" 4@6L @F>L' >@5
%\$)#)&!" DGH>S)/L A.DHf

- 4A24 EC/

4)!!	"! " #* %"	4C2: 4 4A!Z!"F7	"!Z!" &G
4)!"	"! "#1* %"	6-6E "!"F7	#Z!" &G
4)!#	"! "#1* %"	6-6E "!"F7	#Z!" &G
4)!\$	"! "#1* !!"	6-6E "!"F7	#Z!" &G
4)!%	"! " #* %"	4C2: 4 4A!Z!"F7	"!Z!" &G
4)!&	"! " #*(!"	4C2: 4 4A!Z!"F7	"!Z!" #G
4)!'	"! "(!##)!"	>J=Z #ZF7	"!Z!" %&G
4)!("	"! "!%'" #*"	6-6E ##F7	#Z!" #G
4)!)	"! "#1* %"	6-6E "!"F7	#Z!" &G
4)!*	"! "\$!"\$"	7=> ")!A7	Z!" "!"G
4)!!	"! " #*(!"	4C2: 4 4A!Z!"F7	"!Z!" #G
4)!"	"! " #*!"	4C2: 4 4A!Z!"##F7	"!Z!" &G
4)!#	"! "\$!%&!!	>J=Z !ZF7	Z!" &G
4)!\$	"! "#1*%!"	6-6E %F7	#Z!" S&G
4)!%	"! "#1* ("	6-6E %F7	#Z!" &G
4)!&	"! " #""&!!	4C2: 4 S!A7	"!Z!" "<G
4)!'	"! "\$!"("!!	7=> !ZF7	Z!" &G
4)!("	"! "\$!%(!)"	7=> !ZF7	Z!" &G
4)!)	"! " #""&!!	4C2: 4 S!A7	"!Z!" "<G
4)!*	"! " &*S!"	7=> %!!!A7	\$)!!G
4)!#	"! "\$!"*!!	>J=Z !ZF7	"!Z!" #&G
4)!#	"! " #*(!"	4C2: 4 4A!Z!"F7	"!Z!" #G
4)!#\$	"! " #*(!"	4C2: 4 4A!Z!"F7	"!Z!" #G
4)!#%	"! "#1* \$"	6-6E %ZF7	#Z!" &G
4)!#&	"! "#1*#(!"	6-6E ##!F7	#Z!" "!"G
4)!#	"! " #*(!"	4C2: 4 4A!Z!"F7	"!Z!" #G
4)!#	"! " &\$!"	4C2: 4 4A!Z!"##F7	"!Z!" #G
4)!#	"! " %\$&"	4C2: 4 4A!%!A7	Z!" &G
4)!#	"! "#1*%!"	6-6E %F7	#Z!" S&G
4)!\$	"! "#1*!"	6-6E \$F7	#Z!" &G
4)!#\$	"! " #*!"	4C2: 4 4A!Z!"##F7	"!Z!" &G
4)!\$\$	"! " #*(!"	4C2: 4 4A!Z!"F7	"!Z!" #G
4)!\$%	"! "#1* %"	6-6E "!"F7	#Z!" &G
4)!\$&	"! " &!(!"	7=> "!!!!A7	\$)!!G
4)!\$	"! "\$!%&!!	>J=Z !ZF7	Z!" &G
4)!\$	"! "\$!%!"!!	>J=Z !ZF7	Z!" &G
4)!\$	"! "\$!%&!!	>J=Z !ZF7	Z!" &G
4)!\$*	"! " #*(!"	4C2: 4 4A!Z!"F7	"!Z!" #G
4)!\$%	"! " &\$*!"	4C2: 4 4A!Z!"F7	&G
4)!\$!!	"! " #*#!!!	4C2: 4 " &A7	"!Z!" #G
4)!\$!"	"! " #*\$!"	4C2: 4 ##A7	"!Z!" #G
4)!\$!#	"! "#1*)*!!	7=> !Z!"##F7	Z!" 'SG

6Z@ ARCE@ 5DCAE@ 6-2<

4)*!\$	"! "(! \$&"	6-6E %ZF7	#Z!" "!"G
4)*!%	"! "\$!"&!"	7=> !ZF7	Z!" "!"G
4)*!&	"! "\$!"#&!"	>J=Z !ZF7	Z!" 'SG
4)*!("! "#1*%!"	6-6E %F7	#Z!" S&G
4)*!)	"! "#1)!*!"	>E2= 4A "!!	& "Z!"H

- 4@?6EC/

4)!!	"! "*&* &"	E2314@E24E/
4)!"	fi "\$!%&!"	A!B 4@?6EC(A
4)!#	"! "(!"	A 7L 4@?6EC SA
4)!\$	fi "\$!%&!"	A!B 4@?6EC(A
4)!%	"! "*&* &"	E2314@E24E/
4)!&	fi "\$!)!()%!!	A 7L 4@?6EC1&> AE49 "A

- 5@6/

5)!!)! ("*!" *!&	5 @6 F3KDB "(Z#3
5)!#)! ("*!")!"*	5 @6 >>5-*%E
5)!\$)! ("*!")!"*	5 @6 >>5-*%E
5)!*)! ("*!")!"\$%&	5 @6 7F%&
5)!%)! ("*!")!"\$(\$	5 @6 5"?=#HEC
5)!&)! ("*!")!"*"	5 @6 5KZ3
5)!")! ("*!")!"*	5 @6 >>KGE
5)!(")! ("*!")!"!#	5 @6 5?D%
5)!))! ("*!")!"!\$	5 @6 >>K&E
5)!*)! ("*!")!"!\$	5 @6 >>K&E
5)!#)! ("*!")!"*"	5 @6 >>5-*%E
5)!#)! ("*!")!"\$"	5 @6 F3KDB (")3
5)!##)! ("*!")!"*"	5 @6 >>5-*%E
5)!#\$	"! \$&%"\$ ("	=6Z ; F!AC1(Z&>/
5)!#%)! ("*!")!"*"	5 @6 >>5-*%E
5)!#&)! ("*!")!"*"	5 @6 >>5-*%E
5)!#)! ("*!")!"!!	5 @6 >>KGE
5)!#	"! "#1)!%"	D@E 4A !
5)!#!)! ("*!")!"%&	5 @6 6Z##!)
5)!#")! ("*!")!"!\$\$	5 @6 "D\$E((

- 7@C E6 365 /

73)!!	"! %!\$*(!#	7@C E6	"ZF9
73)*!	"! %!\$*(!#	7@C E6	"ZF9

- :4/

:4)!!)! (&!)!"	:4 E="S' 412A
:4)!")! (&!)!"!	:4 ?>#!\$
:4)!#)! (&!)!"!	:4 >K\$!"5
:4)!\$)! (&!)!"!	:4 FA!"*\$!"IE
:4)!%)! (&!)!"!	:4 ?>#!%

- 4@=/

=)!!	"! %!)!*\$!"	:?F4EC	"#F9
=)!"	"! %!)!*\$!"	:?F4EC	ZF9

ĀĀĀĀ	ĀĀĀĀ@	ĀĀĀĀ@	ĀĀĀĀ	ĀĀĀĀ	ĀĀĀĀ@	ĀĀĀĀ@	ĀĀĀĀ
=)!#	"!%#"	:?F4EC	Š*F9	C)#	"!#&%%#	>E2=	#Z# # "Z!H
=)*!	"!%'1'(%"	:?F4EC	ŠS9	C)\$	"!#&1%\$1"	4C3@	"& & "Z!H
	- A@E@FA-C /			C)#	"!#&%%#	>E2=	#Z# # "Z!H
A9)!!	'1'!!!)'(1!"	A@E@FA-C	A! #S## @	C)\$	"!#&1\$(1"	4C3@	!Z6 & "Z!H
A9)!"	'1'!!!)'(1!"	A@E@FA-C	A! #S## @	C)\$%	"!#&1*(1#	>E2= @:56	!Z & #H
	- EC2DDE@ /			C)\$&	"!#'1) #1"	>E2= 4A	"< & "Z!H
B)!!)1(#1!"!1#	EC2DDE@	>D5!"1CE	C)\$	"!#'1)'%"	D@E 4A	!
B)!")1(#1!"!1#	EC2DDE@	>D5!"1CE	C)\$	"!#&1%*1"	4C3@	"Z& & "Z!H
B)!#	'1&"	EC2DDE@	#D#)%#-3D@V	C)\$	"!#!1!*&"	4C3@	%! & "Z!H
B)!\$	'1&"	EC2DDE@	#D#)%#-3D@V	C)\$*	"!#'1)S1"	>E2= 4A	"!< & "Z!H
B)!%)1(#1!"!1!&	EC2DDE@	>D3!"1CE	C)%	"!#)1)%1"	>E2= 4A	"< !Z& "Z!H
B)!')1(#1%#1##	EC2DDE@	F?##"	C)%	"!#)1)&&"	>E2= 4A	#Z# !Z& "Z!H
B)!(")1(#1!"!1!&	EC2DDE@	>D3!"1CE	C)%#	"!#)1)&1"	>E2= 4A	#Z< !Z& "Z!H
B)!))1(#1%#1##	EC2DDE@	F?##"	C)%\$	"!#'1)' \$"	>E2= 4A	ŠS & "Z!H
B)!*)1(#1!"!1!&	EC2DDE@	>D3!"1CE	C)%%	"!#)1)'(1"	>E2= 4A	'Z< !Z& "Z!H
B)!")1(#1!"!1#	EC2DDE@	>D5!"1CE	C)%&	"!#)1)*&"	>E2= 4A	"!< !Z& "Z!H
B)!")1(#1%#1##	EC2DDE@	F?##"	C)%	"!#'1)S1"	>E2= 4A	## & "Z!H
B)!")1(#1!"!1!&	EC2DDE@	>D3!"1CE	C)%	"!#'1)S1"	>E2= 4A	##< & "Z!H
B)!")1(#1%#1##	EC2DDE@	F?##"	C)%	"!#'1)S1"	>E2= 4A	%!< & "Z!H
B)!")1(#1!"!1!&	EC2DDE@	>D3!"1CE	C)%	"!#'1)S1"	>E2= 4A	"# & "Z!H
B)!")1(#1!"!1#	EC2DDE@	>D5!"1CE	C)%#	"!#'1)!*1"	>E2= 4A	"!! & "Z!H
B)!"	'1&&1(!!!"	EC2DDE@	FA&-%K!S1/	C)\$	"!#'1)S1"	>E2= 4A	"!< & "Z!H
	- @DDE@ /			C)\$%	"!#'1)%1"	>E2= 4A	##< & "Z!H
C)!!	"!#'1)S1"	>E2= 4A	##< & "Z!H	C)\$&	"!#'1)%1"	>E2= 4A	%< & "Z!H
C)!"	"!#'1)%1"	>E2= 4A	##< & "Z!H	C)!'	"!#'1) #1"	>E2= 4A	"< & "Z!H
C)!#	"!#'1)%1"	>E2= 4A	%< & "Z!H	C)'"	"!#&%&!!	>E2=	%!< "" "Z!H
C)!\$	"!#'1)S1"	>E2= 4A	##< & "Z!H	C)'#	"!#'1)%1"	>E2= 4A	%< & "Z!H
C)!%	"!#&1)%1"	4C3@	ŠS & "Z!H	C)'\$	"!#)1)&1"	>E2= 4A	"Z< !Z& "Z!H
C)!&	"!#)1)&"	>E2= 4A	"& !Z& "Z!H	C)!'&	"!#&1%1"	4C3@	S1 & "Z!H
C)!("	"!#)1)%&"	>E2= 4A)# !Z& "Z!H	C)''	"!#*1(%1&	>E2=	"!< & "Z!H
C)!)	"!##*S1"	7D36	!Z "!" "Z!H	C)'("!#&%&!!	>E2=	%!< "" "Z!H
C)!*	"!#)1)'%"	>E2= 4A	"\$ & !Z& "Z!H	C)')*	"!#)1)'&"	>E2= 4A	ŠZ< !Z& "Z!H
C)!"	"!#)1)'*1"	>E2= 4A)Z# !Z& "Z!H	C)!("!#*1(&1*"	>E2=	## & "Z!H
C)!"	"!#&S1S1!!	=E1;F>AC1 ŠZ>/		C)('	"!#'1)%&"	>E2= 4A	"!< & "Z!H
C)!"#	"!#&%1)1#	>E2=	%!< "" "Z!H	C)(\$	"!#)1)1)"	>E2= 4A	%< !Z& "Z!H
C)!"\$	"!#&%1)1#	>E2=	%!< "" "Z!H	C)(\$%	"!#)1)*&"	>E2= 4A	"!< !Z& "Z!H
C)!"%	"!#)1)'#"	>E2= 4A	&!< !Z& "Z!H	C)(\$&	"!#'1) #1"	>E2= 4A	"< & "Z!H
C)!"&	"!#'1)'%"	D@E 4A	!	C)(\$(("!#&%S1!!	>E2=	ŠS "" "Z!H
C)!"	"!#)1)'S1"	>E2= 4A	%! !Z& "Z!H	C)(\$)	"!#&%%1!!	>E2=	"# "" "Z!H
C)!"("!#&1\$S1"	4C3@	"! & "Z!H	C)(\$*	"!#&%%1!!	>E2=	"# "" "Z!H
C)!)	"!#'1)!S1"	>E2= 4A	S1 & "Z!H	C)(\$)!	"!#&%%1!!	>E2=	"# "" "Z!H
C)!"*	"!#)1)'S1"	>E2= 4A	"!! !Z& "Z!H	C)(\$)"	"!#&%%1!!	>E2=	"# "" "Z!H
C)!"#	"!#'1)S1"	>E2= 4A	"!< & "Z!H	C)(\$)\$	"!#)1)%1"	>E2= 4A	"< !Z& "Z!H
C)!"#	"!#'1)S1"	>E2= 4A	##< & "Z!H	C)(\$)%	"!#'1) #1"	>E2= 4A	"< & "Z!H
C)!"%	"!#)1)*1"	>E2= 4A	"#< !Z& "Z!H	Q*!"	"!#!1' #1"	4C3@	"!< & "Z!H
C)!"&	"!#'1)S1"	>E2= 4A	"!< & "Z!H	Q*!%	"!#&1%#1"	4C3@	"!< & "Z!H
C)!"	"!#'1) #1"	>E2= 4A	%Z< & "Z!H	Q*!("!#!1' #1"	4C3@	"!< & "Z!H
				Q*!)	"!#!1' #1"	4C3@	"!< & "Z!H

Note : The components identified by shading and marked Δ are critical for safety. Replace only with the part numbers specified in the parts list.

65Z@	ARCEZ@	56DCAE@	6B-2C<	65Z@	ARCEZ@	56DCAE@	6B-2C<
Q*!*	"1#1"#\$"	4C3@	"!< & "z#H	4"!("1"#{*S"	6-6E	"!F7 #Z!" " G
Q*!"	"1#1)#{1"	>E2= 49 A	SZ< & "z!H	4"!)	"1" #*#1"	4C2: 4 49 A S\$A7	Z!" &G
Q*""	"1#1)#{1"	>E2= 49 A	"< & "z!H	4"!*	"1" #*#1"	4C2: 4 49 A S\$A7	Z!" &G
Q*"#	"1#1)S"	>E2= 49 A	"!< & "z!H	4\$!	"1" #*}1"	4C2: 4 49 A!Z!%F7	"!Z!" &G
Q*"\$	"1#1)!*1"	>E2= 49 A	"!< & "z!H	4\$#	"1#1)'%"	DOE 49 A !	
- 6DDE@ 23-6 /				4\$\$	"1" #*#1"	4C2: 4 49 A"#A7	Z!" &G
G)!"	"1##& #1*"	6L 2L 25 L 46-6E #		4\$%	"1#1)'%"	DOE 49 A !	
- D@C< 82A/				4\$("1" #&)*1"	4C2: 4 49 A!Z!F7	"!Z!" "G
D8)!!	"1&(1%*1#	82A D@C<		4##!	"1" #1%&1"	6-6E %F7	#Z!" S&G
- EC2D@C-6C /				4##!"	"1" %&!%"	4C2: 4 49 A!Z!F7	"!Z!" #&G
E)!!	"1%\$1' *11"	EC2D@C-6L 76C E615E/		4##!&	"1" #1("&*"	4C2: 4 49 A!Z!#F7	"! " " G
- EC2D@C-6C /				4##!'	"1" #1%&1"	6-6E %F7	#Z!" S&G
GRcZR_e ARced <G#)7B)'				4##!("1" #* 1"	4C2: 4 49 A!Z!##F7	"!Z!" &G
- 6DDE@ /				4##!*	"1" #1("&*"	4C2: 4 49 A!Z!#F7	"! " " G
Q*!!	"1#1%}1#	>E2= @: 56)Z# & S		4##!"	"1" #1("&*"	4C2: 4 49 A!Z!#F7	"! " " G
Q*!#	"1#1%}1#	>E2= @: 56)Z# & S		4##""	"1" #* 1"	4C2: 4 49 A!Z!##F7	"!Z!" &G
Q*!\$	"1#&' "1#	>E2= @: 56 'Z< & S		4##"#	"1" #* 1"	4C2: 4 49 A!Z!##F7	"!Z!" &G
Q*!&	"1#1%}1#	>E2= @: 56)Z# & S		4##"\$	"1" #* 1"	4C2: 4 49 A!Z!##F7	"!Z!" &G
Q*!'	"1#1%}1#	>E2= @: 56)Z# & S		4##"%	"1" #1("&*"	4C2: 4 49 A!Z!#F7	"! " " G
- EC2D@C-6C /				4##""	"1" #*#1"	4C2: 4 49 A!!A7	Z!" &G
E)!!	"1%\$S)1#	EC2D@C-6C 2DJ 7-J32k ?1' !#ZK#%		4##"("1" #1* %"	6-6E "F7	#Z!" &G
GRcZR_e ARced <G\$#7B)'				4##")	"1" #1* %"	6-6E "F7	#Z!" &G
- 6DDE@ /				4##*	"1" #1%&1"	6-6E %F7	#Z!" S&G
Q*!!	"1#&')1#	>E2= @: 56 "!" & S		4## #	"1" #1%&1"	6-6E %F7	#Z!" S&G
Q*!#	"1#&' *1#	>E2= @: 56 "# & S		4## #	"1" %&1"	4C2: 4 49 A!Z!F7	#&G
Q*!\$	"1#&' *1#	>E2= @: 56 "# & S		4## ##	"1" #1* %"	6-6E "F7	#Z!" &G
Q*!&	"1#&' *1#	>E2= @: 56 "# & S		4## #S	"1" %&1"	4C2: 4 49 A!Z!F7	#&G
Q*!'	"1#&')1#	>E2= @: 56 "!" & S		4## #%	"1" #1* %"	6-6E "F7	#Z!" &G
- EC2D@C-6C /				4## #	"1" %&1"	4C2: 4 49 A!Z!F7	#&G
E)!!	"1%\$%&#	EC2D@C-6C 2DJ 7-J32k ?1' !#ZK#%		4## #("1" %&1"	4C2: 4 49 A!Z!F7	#&G
fi 2!"\$!#1* "12 2 3`RcU 4` ^a]VeV <G#)7B) '3				4## #)	"1" #* 1"	4C2: 4 49 A"Z&A7	!Z&A7 &G
<G\$#7B) '3				4## #*	"1" #* 1"	4C2: 4 49 A"Z&A7	!Z&A7 &G
fi 2!"\$!#1* #12 2 3`RcU 4` ^a]VeV <G#)7B) '6L				4## \$	"1" #1("&*"	4C2: 4 49 A!Z!#F7	"! " " G
<G\$#7B) '6 <G\$#7B) '<				4## #	"1" #1("&*"	4C2: 4 49 A!Z!#F7	"! " " G
fi 2!"\$!#1* (#12 2 3`RcU 4` ^a]VeV <G\$#7B) 'F				4## %	"1" #*#1"	4C2: 4 49 A!!A7	Z!" &G
2 3`RcU 4` ^ ^` _ ARced				4## !	"1" #1* 1"	6-6E "F7	#Z!" &G
- 4A24 EC /				4## "	"1" %&!%"	4C2: 4 49 A!Z!F7	"!Z!" #&G
4"!\$	"1" #*#1"	4C2: 4 49 A!!A7	Z!" &G	4## #	"1" #1* 1"	6-6E "F7	#Z!" &G
4"!%	"1" #*#1"	4C2: 4 49 A!!A7	Z!" &G	4## \$	"1" #1* \$"	6-6E %Z!F7	#Z!" &G
4"!&	"1" #1* (1"	6-6E %F7	#Z!" &G	4## %	"1" #1* 1"	6-6E "F7	#Z!" &G
4"!'	"1" #*}1"	4C2: 4 49 A!Z!%F7	"!Z!" &G	4## &	"1" #1* 1"	6-6E "F7	#Z!" &G
				4##'	"1" #*(1"	4C2: 4 49 A!Z!F7	"!Z!" #&G
				4##("1" #*(1"	4C2: 4 49 A!Z!F7	"!Z!" #&G
				4##!	"1" #1*S"	6-6E %!F7	#Z!" " G
				4##"	"1" #1%&1"	6-6E %F7	#Z!" S&G
				4## #	"1" #1%&1"	6-6E %F7	#Z!" S&G
				4## \$	"1" #1%&1"	6-6E %F7	#Z!" S&G

ČZžž	ACEž@	5DICA@	Č-Z<	ČZžž	ACEž@	5DICA@	Č-Z<
4#% %	"1" #1*%&!"	6-6E %F7	#ž!~ Š&G	4# #	"1" %&!"	4C2: 4 4A!žF7	#&G
4#&	"1"!(1) #1"	4C2: 4 4A!žF7	"!ž!" " G	4# \$	"1" %&!"	4C2: 4 4A!žF7	#&G
4#'	"1"!(1) #1"	4C2: 4 4A!žF7	"!ž!" " G	4# %	"1" %&!"	4C2: 4 4A!žF7	#&G
4#!	"1" \$1 (&!!	7=> !ž)F7	ž!~ &G	4# &	"1" #*(1)"	4C2: 4 4A!žF7	"!ž!" #&G
4#"	"1" & #1"	4C2: 4 4A!ž#F7	" G	4#'	"1" #*(1)"	4C2: 4 4A!žF7	"!ž!" #&G
4#&#	"1" \$'Š&!!	4C2: 4 4A&!A7	ž!~ &G	4#("1" &'(1)"	4C2: 4 4A!ž%F7	"!ž!" " G
4#&\$	"1" &Š\$1"	4C2: 4 4A!žF7	"!ž!" &G	4#)	"1" #*(1)"	4C2: 4 4A!žF7	"!ž!" #&G
4#&%	"1" #*'1"	4C2: 4 4A!ž!##F7	"!ž!" &G	4#*	"1" #*(1)"	4C2: 4 4A!žF7	"!ž!" #&G
4#&&	"1" #*#(1)"	4C2: 4 4A!!A7	ž!~ &G	4#!	"1" #*(1)"	4C2: 4 4A!žF7	"!ž!" #&G
4#&'	"1" \$! #1*"	4C2: 4 4A!žF7	"!ž!" &G	4#%	"1" #*(1)"	4C2: 4 4A!žF7	"!ž!" #&G
4#&("1" %&&"	4C2: 4 4A#žF7	" G	4#&	"1" #*(1)"	4C2: 4 4A!žF7	"!ž!" #&G
4#&)	"1" #1* \$"	6-6E %žF7	#ž!~ &G	4#("1" #*(1)"	4C2: 4 4A!žF7	"!ž!" #&G
4#&*	"1" &Š\$1"	4C2: 4 4A!žF7	"!ž!" &G	4#)	"1" #*(1)"	4C2: 4 4A!žF7	"!ž!" #&G
4#&!	"1" %&!"	4C2: 4 4A!žF7	#&G	4#*	"1" #1* %"	6-6E "F7	#ž!~ &G
4#&"	"1" %&!"	4C2: 4 4A!žF7	#&G	4#&\$	"1" #1*%&!"	6-6E %!F7	#ž!~ #&G
4#&#	"1" #1*%&!"	6-6E ##!F7	#ž!~ #&G	4#&%	"1"!(##)!!	4C2: 4 %!A7	"!ž!" &!G
4#&\$	"1" #1*%&!"	6-6E ##!F7	#ž!~ #&G	4#&&	"1" %&!"	4C2: 4 4A!žF7	#&G
4#&%	"1" %&!"	4C2: 4 4A!žF7	#&G	4#&'	"1" &%!1"	4C2: 4 4A!ž!F7	ž!~ #&G
4#&!&	"1"!(1*%)"	6-6E "!!!F7	#ž!~ &G	4#&("1" #1*%&!"	6-6E %!F7	#ž!~ #&G
4#&!"	"1"!(1*%)"	6-6E "!!!F7	#ž!~ &G	4#&*	"1" #1*)1"	6-6E "!!!F7	#ž!~ &G
4#&#	"1" %&!"	4C2: 4 4A!žF7	#&G	4#&!&	"1" %&!"	4C2: 4 4A!žF7	#&G
4#&\$	"1" %&!"	4C2: 4 4A!žF7	#&G	4#&"	"1" \$!%1"	>J-Z !ž#F7	ž!~ "!!G
4#&%	"1" #1*%&!"	6-6E !žF7	#ž!~ &G	4#&#	"1"!(##)!!	>J-Z !žF7	"!ž!" "!!G
4#&&	"1"!(1))1"	6-6E %F7	#ž!~ #&G	4#&\$	"1" \$!()&"	>J-Z !žF7	ž!~ "!!G
4#&'	"1"!(1))1"	6-6E %F7	#ž!~ #&G	4#!	"1" %&!"	4C2: 4 4A!žF7	#&G
4#&("1" #1*%&!"	6-6E !žF7	#ž!~ &G	4# \$	"1" %&!"	4C2: 4 4A!žF7	#&G
4#&)	"1" &Š\$1"	4C2: 4 4A!žF7	"!ž!" &G	4#'	"1"!(%&!"	6-6E "!!!F7	#ž!~ #&G
4#&#	"1" %&!%!"	4C2: 4 4A!žF7	"!ž!" #&G	4#)	"1" #1((1)"	6-6E "!!!F7	#ž!~ " G
4#&\$	"1" %&!%!"	4C2: 4 4A!žF7	"!ž!" #&G	4#*	"1"!(%&!"	6-6E "!!!F7	#ž!~ #&G
4#&%	"1"!(1*(1)"	6-6E ##F7	#ž!~ &G	4#("1" #1((1)"	6-6E "!!!F7	#ž!~ " G
4#! \$	"1"!(1) #1"	4C2: 4 4A!žF7	"!ž!" " G	4## \$	"1" \$!%(1)"	7=> !žF7	ž!~ &G
4#*"	"1"!(1) #1"	4C2: 4 4A!žF7	"!ž!" " G	4##	"1" #1*%&!"	6-6E "!!!F7	#~ 'ž&G
4&! \$	"1" #1*!1"	6-6E "F7	#ž!~ &G	4##*	"1" #1*Š&!"	6-6E %!F7	#ž!~ " G
4&!'	"1" #1*Š\$1"	6-6E "!!!F7	#ž!~ " G	4#&%	"1" \$!%(1)"	7=> !žF7	ž!~ &G
4&!*"	"1" #1* %"	6-6E "F7	#ž!~ &G	4#&&	"1" #1&&!"	6-6E ##!F7	#ž!~ &G
4&!"	"1" #1*%&!"	6-6E %F7	#ž!~ Š&G	4# \$	"1" #1*%&!"	6-6E "!!!F7	#~ 'ž&G
4&""	"1" #1* %"	6-6E "F7	#ž!~ &G	4# \$	"1" #1((1)"	6-6E "!!!F7	#ž!~ " G
4&""#	"1" #1* %"	6-6E "F7	#ž!~ &G	4# \$	"1" \$!%(1)"	7=> !žF7	ž!~ &G
4&""'	"1" #1* %"	6-6E "F7	#ž!~ &G	4# \$*	"1"!(%&!"	6-6E "!!!F7	#ž!~ #&G
4&""("1" #1*%&!"	6-6E %F7	#ž!~ Š&G	4# %	"1" %&!"	4C2: 4 4A!žF7	#&G
4&"")	"1" %&!"	4C2: 4 4A!žF7	#&G	4# %	"1" %&!"	4C2: 4 4A!žF7	#&G
4&""*	"1"!(1) #1"	4C2: 4 4A!žF7	"!ž!" " G	4# #	"1"!(%&!"	6-6E "!!!F7	#ž!~ #&G
4&""#	"1" &'(1)"	4C2: 4 4A!ž%F7	"!ž!" " G	4# \$	"1"!(%&!"	6-6E "!!!F7	#ž!~ #&G
4&""#	"1" &'(1)"	4C2: 4 4A!ž%F7	"!ž!" " G	4# %&	"1" %&!"	4C2: 4 4A!žF7	#&G
4&""##	"1" %&!"	4C2: 4 4A!žF7	#&G	4# #&	"1" %&!"	4C2: 4 4A!žF7	#&G
4&# \$	"1" #1*%&!"	6-6E %F7	#ž!~ Š&G	4# %	"1"!(%&!"	6-6E "!!!F7	#ž!~ #&G
4&# %	"1" %&!"	4C2: 4 4A!žF7	#&G	4# %	"1"!(%&!"	6-6E "!!!F7	#ž!~ #&G
4&# &	"1" #1* %"	6-6E "F7	#ž!~ &G	4# %	"1" %&!"	4C2: 4 4A!žF7	#&G
4&#'	"1" #*(1)"	4C2: 4 4A!žF7	"!ž!" #&G	4# %	"1" %&!"	4C2: 4 4A!žF7	#&G
4&#"	"1" #1*%&!"	6-6E %F7	#ž!~ Š&G	4# %	"1"!(%&!"	6-6E "!!!F7	#ž!~ #&G

G6Z@Z	A@CEZ@	56DCAE@	G6-Z<	G6Z@Z	A@CEZ@	56DCAE@	G6-Z<
4 #&	"1"!%' &"	G6E	"!!F7 #Z!~ #G	5&%)!(*!"!!"!%	5 @6 C5'8D#	
4 #&#	"1"#1*' \$"	G6E	%ZF7 #Z!~ &G	5&&)!(*!"!)!!"\$	5 @6 8A)5	
4 #&S	"1"%"&!"	4C2>: 4 49A!ZF7	#G	5 #")!(*!"!##*(5 @6 5H967	
4 #&%	"1"\$!\$%"	>J=Z	!Z%F7 &Z!~ &G	5 #S)!(*!"! '\$(!	5 @6 5'?=#F	
4 #&&	"1"#1*\$&"	G6E	%!F7 #Z!~ "' G	5 #%)!(*!"! '\$(!	5 @6 5'?=#F	
4 #&	"1"#1*%!"	G6E	%F7 #Z!~ \$G	5 #&)!(*!"!&!"\$	5 @6 >">2'&#H#E	
- 4@76E@/				5 #')!(*!"!)!"*(5 @6 >>5-*"E	
4#!#	fi "1&%&(!"	AfB 4@76E@%A		5 #()!(*!"!)!"*(5 @6 >>5-*"E	
4#S!	fi "1&%&!"	AfB 4@76E@ (A		5 #))!(*!"!)!"*(5 @6 >>5-*"E	
4#S"	fi "1&%&*"	AfB 4@76E@ 'A		5 #*)!(*!"!)!"*(5 @6 >>5-*"E	
4#S#	fi "1)"'!"*(!&	AfB 4@76E@)A		5 #!)!(*!"!"!!"!	5 @6 C5'8D#	
4#%!&	fi "1)"'!"*(%&	AfB 4@76E@ \$A		5 #")!(*!"!)!"&	5 @6 6*"!G	
4#&"	fi "1&%&(!"	AfB 4@76E@%A		5 #S)!(*!"!##*(5 @6 5H967	
4S!!	fi "1&%&!"	AfB 4@76E@ (A		5 #%)!(*!"!&!)%	5 @6 F3H#B"(!Z&3	
4S!"	"1"*!"(((\$"	AfB1>: 4@4@76E@ "'A		- 7CC#6 365 /			
4S!#	fi "1)"'!"&"	4@76E@L 3@C5 E@3@C5 \$A		73#&!	"1&&&\$S\$!!	=6ZL; F>AC1 &Z>>/	
4S!%	fi "1)"'!"*(%&	AfB 4@76E@ \$A		73#&"	"1&&&\$S\$!!	=6ZL; F>AC1 &Z>>/	
4S!)	"1"*!"(((&"	AfB1>: 4@4@76E@ "\$A		73#"	"1&&&\$S\$!!	=6ZL; F>AC1 &Z>>/	
4&#(fi "1)"'!"!\$%"	5? 4@76E@ AfB *A		73#%	"1&&&\$S\$!!	=6ZL; F>AC1 &Z>>/	
4&#*	fi "1&%&#!"	AfB 4@76E@ &A		- :4/			
4 #!	fi "1)"'!"*(!&	AfB 4@76E@ 'A		:4#!!	"1(!!"!\$!"	:4 >D@%'8 B2'3"	
4 #"	fi "1&%&!"	AfB 4@76E@ (A		:4##!)!(&!"!!"*	:4 F@P&&8#	
4 # #	fi "1&%&!"	AfB 4@76E@ (A		:4#S!)!(&!"&'!	:4 E52#)##5 "\$C	
4 # \$	"1"*&*"&"	E2314@E24E/		:4#%!)!(&!"&&#&	:4 E52%#	
4 *!	fi "1&%&!"	AfB 4@76E@ (A		:4#&!	"1(!%!)!"!	:4 E52#*	
- 5 @6 /				:4&#!#)!(&!"\$%&%	:4 42!!&25	
5#!#)!(*!"!)!"*(5 @6 >>5-*"E		:4&!%)!(&!"!)!"\$%#	:4 =2 &!"!72	
5##!)!(*!"*#!"&	5 @6 9DZ'73#		:4&&!)!(&!"*!"!	:4 DK*\$*2	
5##")!(*!"*#!"&	5 @6 9DZ'73#		:4 #!)!(&!"%!"#	:4 =!)!&G=D	
5## #)!(*!"!&!"\$	5 @6 >">2'&#H#E		:4 # #)!(&!"%!"*	:4 AB'4# \$#K	
5&!)!(*!"!&!"\$	5 @6 >">2'&#H#E		:4 # %)!(&!"%!"*	:4 =!)!*G=D	
5&!!)!(*!"!)!"*(5 @6 >>5-*"E		:4 # ()!(&!"%!"*	:4 AB'4# \$#K	
5&!\$)!(*!"!"!)"	5 @6 C5'6D		:4 #!)!(&!"%&&#&	:4 32 \$E	
5&!%)!(*!"*(!"**	5 @6 5H&Z'3		:4 #"	"1(!!"%!"!	:4 <#&3E	
5&#!)!(*!"!)!"*(5 @6 >>5-*"E		:4 # #)!(&!"%!"*	:4 D1)!"!D=7"!"	
5&#")!(*!"!)!"*	5 @6 >>SKGE		- D@KE /			
5&# #)!(*!"!)!"*(5 @6 >>5-*"E		;##!	"1()%' \$!"	;24L A? #A	
5&#\$)!(*!"!)!"*(5 @6 >>5-*"E		- 4@= /			
5&#%)!(*!"!)!"*(5 @6 >>5-*"E		=!"!	"1%%(!"!#	7CC#6 !F9	
5&#&)!(*!"!)!"*(5 @6 >>5-*"E		=!"!"	"1%%(!"!#	7CC#6 !F9	
5&#')!(*!"!)!"*(5 @6 >>5-*"E		=!"!#	"1%)!"'&\$"	:?F4E@ "!!F9	
5&#()!(*!"!)!"*(5 @6 >>5-*"E		=!"!\$	"1%)!"'!\$S"	:?F4E@ "!"F9	
5&#))!(*!"!)!"*(5 @6 >>5-*"E		=!"!%	"1%#*(!"!#	:?F4E@ "F9	
5&#*)!(*!"!)!"*(5 @6 >>5-*"E		=!"\$!	"1&&&\$S\$!!	=6ZL; F>AC 1&Z>>/	
5&#!)!(*!"!)!"*(5 @6 >>5-*"E		=!"\$"	"1%)!"'!#S"	:?F4E@)Z#F9	
5&#")!(*!"!)!"*(5 @6 >>5-*"E		=#!!	"1%#*#)"!#	:?F4E@ "F9	
5&# #)!(*!"!)!"*(5 @6 >>5-*"E					

G6ZQZ	AQCEZ@	56DCAE@	G6ZC<
=#!"	"1%%*#)1#	:?F4RC	"F9
=#"	"1%%*#)1#	:?F4RC	"F9
=#%!	"1%'1*(1#	:?F4RC	"!!F9
=#%"	"1&&&S\$!!	=6ZL;F>AG 1&Z>/	
=#%#	"1&&&S\$!!	=6ZL;F>AG 1&Z>/	
=#&!	"1&&&S\$!!	=6ZL;F>AG 1&Z>/	
=#&"	"1&&&S\$!!	=6ZL;F>AG 1&Z>/	
=#&!	"1%#&&S	:?F4RC	"!F9
=#&"	"1&&&S\$!!	=6ZL;F>AG 1&Z>/	
=#&#	"1&&&S\$!!	=6ZL;F>AG 1&Z>/	
=#S	"1%*(%S"#	:?F4RC	"!!F9
=#("1%#&&S	:?F4RC	"!F9
=#!	"1&&&S\$!!	=6ZL;F>AG 1&Z>/	
=#"	"1&&&S\$!!	=6ZL;F>AG 1&Z>/	
=#S	"1%#&&S"	:?F4RC	"&F9
=#)	"1%*(%S"#	:?F4RC	"!!F9
=#*	"1%'1*(1"	:?F4RC	"!F9

- AC@GRC>@F=6/

AD#!!	'	"1)"1&&1#	:4=?< %2 !G
AD#!"	'	"1)"1&&1#	:4=?< %2 !G

- K2DDE@/

B"!!)1(#1!#)1#	K2DDE@ #D#S1E&/
B#!)1(#1!#)1#	K2DDE@ #D#S1E&/
B#")1(#1!#)1#	K2DDE@ #D#S1E&/
B"!!)1(#1!"1)1#	K2DDE@ >D!"1CE
B\$!)1(#1!"1)1#	K2DDE@ >D!"1CE
B\$")1(#1!"1)1#	K2DDE@ >D!"1CE
B##!)1(#1!"1)1#	K2DDE@ >D!"1CE
B##")1(#1!"1)1#	K2DDE@ >D!"1CE
B##)1(#1!"1)1#	K2DDE@ >D!"1CE
B\$!)1(#1!"1)1#	K2DDE@ >D!"1CE
B\$")1(#1!"1)1#	K2DDE@ >D!"1CE
B\$#)1(#1!"1)1#	K2DDE@ >D!"1CE
B%!)1(#1!"1)1#	K2DDE@ >D!"1CE
B%")1(#1!"1)1#	K2DDE@ >D!"1CE
B&!)1(#1!"1)1#	K2DDE@ >D!"1CE
B&")1(#1!"1)1#	K2DDE@ >D!"1CE
B&#)1(#1!"1)1#	K2DDE@ >D!"1CE
B&S)1(#1!"1)1#	K2DDE@ >D!"1CE
B&%)1(#1!#(1S)	K2DDE@ 5E2%6AE%
B&!!)1(#1!"1)1#	K2DDE@ >D!"1CE
B&!")1(#1!"1)1#	K2DDE@ >D!"1CE
B&#!)1(#1!"1)1#	K2DDE@ >D!"1CE
B&#")1(#1!"1)1#	K2DDE@ >D!"1CE
B&#)1(#1!"1)1#	K2DDE@ >D!"1CE
B&S)1(#1!"1)1#	K2DDE@ >D!"1CE

G6ZQZ	AQCEZ@	56DCAE@	G6ZC<
B#%)1(#1!"1)1#	K2DDE@ >D!"1CE	
B#&)1(#1!"1)1#	K2DDE@ >D!"1CE	
B#')1(#1!"1)1#	K2DDE@ >D!"1CE	
B#()1(#1!"1)1#	K2DDE@ >D!"1CE	
B#))1(#1!"1)1#	K2DDE@ >D!"1CE	
B#*)1(#1!"1)1#	K2DDE@ >D!"1CE	
B#!)1(#1!"1)1#	K2DDE@ >D!"1CE	
B#")1(#1!"1)1#	K2DDE@ >D!"1CE	
B#%)1(#1!"1)1#	K2DDE@ >D!"1CE	
B#&)1(#1!"1)1#	K2DDE@ >D!"1CE	
B#')1(#1!"1)1#	K2DDE@ >D!"1CE	
B#()1(#1!"1)1#	K2DDE@ >D!"1CE	
B#))1(#1!"1)1#	K2DDE@ >D!"1CE	
B#*)1(#1!"1)1#	K2DDE@ >D!"1CE	
B##)1(#1!"1)1#	K2DDE@ >D!"1CE	
B#\$)1(#1!"1)1#	K2DDE@ >D!"1CE	
B#%)1(#1!"1)1#	K2DDE@ >D!"1CE	
B#&)1(#1!"1)1#	K2DDE@ >D!"1CE	
B#')1(#1!"1)1#	K2DDE@ >D!"1CE	
B#()1(#1!"1)1#	K2DDE@ >D!"1CE	
B#))1(#1!"1)1#	K2DDE@ >D!"1CE	
B#*)1(#1!"1)1#	K2DDE@ >D!"1CE	

- G@DE@/

;S!"	"1#')'%"	D@E 4A !
;S!S	"1#')'%"	D@E 4A !
;S!%	"1#')'%"	D@E 4A !
;S!"	"1#')'%"	D@E 4A !
;S"!'	"1#')'%"	D@E 4A !
;C!"	"1#')'%"	D@E 4A !
;C!#	"1#')'%"	D@E 4A !
;C!S	"1#')'%"	D@E 4A !
;C!%	"1#')'%"	D@E 4A !
;C!&	"1#')'%"	D@E 4A !
;C!"'	"1#')'%"	D@E 4A !
;C!(!	"1#')'%"	D@E 4A !
;C!()	"1#')'%"	D@E 4A !
;C!*'	"1#')'%"	D@E 4A !
;C!"S	"1#')'%"	D@E 4A !
;C!#S	"1#')'%"	D@E 4A !
;C!#&	"1#')'%"	D@E 4A !
;C!#("1#')'%"	D@E 4A !
;Q!#	"1#')'%"	D@E 4A !
;Q!S	"1#')'%"	D@E 4A !
C!"	"1#')'%"	D@E 4A !
C"!!	"1#')'%"	>E2 4A "!" & "Z"!H
C"!#	"1#')'%"	>E2 4A #Z# & "Z"!H
C"!S	"1#')'%"	>E2 4A "!" & "Z"!H
C#!	"1#')'%"	>E2 4A SZ & "Z"!H
C#"	"1#')'%"	>E2 4A SZ & "Z"!H
C##	"1#')'%"	>E2 4A #Z# & "Z"!H
C#%	"1#')'%"	>E2 4A "!" & "Z"!H
C#&	"1#')'%"	>E2 4A #Z# & "Z"!H
C#("1#')'%"	>E2 4A "!" & "Z"!H

СЗЉ	АЦЕЖ@	5DICAЕ@	С-З<	СЗЉ	АЦЕЖ@	5DICAЕ@	С-З<
C"!!	"1#'1)'%""	DQE 4A	!	G\$ ("1#'1)S1""	>E2= 4A	##< & "Z!H
C"!#	"1#'1)'%""	DQE 4A	!	G\$)	"1#'1)#&""	>E2= 4A	#Z# & "Z!H
C"!S	"1#'1)'%""	DQE 4A	!	G\$*	"1#'1)#&""	>E2= 4A	#Z# & "Z!H
C"!&	"1#'1)'%""	DQE 4A	!	G\$!	"1#%1\$*1""	4C3@	%Z & "Z!H
C"!'	"1#'1)'%""	DQE 4A	!	G\$"	"1#'1)!*1""	>E2= 4A	"!! & "Z!H
C"!)	"1#'1)'%""	DQE 4A	!	G\$#	"1#%1\$*1""	4C3@	%Z & "Z!H
C"#!	"1#'1)S1""	>E2= 4A	")< & "Z!H	G\$S	"1#'1)"\$""	>E2= 4A	## & "Z!H
C"###	"1#'1)#1""	>E2= 4A	"< & "Z!H	G\$%	"1#'1)!*1""	>E2= 4A	"!! & "Z!H
C\$!	"1#'1)#1""	>E2= 4A	"< & "Z!H	G\$&	"1#'1)"\$""	>E2= 4A	## & "Z!H
C\$\$	"1#'1)!&""	>E2= 4A	% & "Z!H	G\$"	"1#'1)!*1""	>E2= 4A	"!! & "Z!H
C\$%	"1#'1)#1""	>E2= 4A	"< & "Z!H	G\$("1#'1)!*1""	>E2= 4A	"!! & "Z!H
G!!	"1%%(!1#	7CEB	!F9	G#!	"1#%1%##""	4C3@	#Z< & "Z!H
G!"	"1%%(!1#	7CEB	!F9	G#"	"1#'1)"(1""	>E2= 4A	%! & "Z!H
G!#	"1#'1)%&""	>E2= 4A	"!!< & "Z!H	G##	"1#)1)#1""	>E2= 4A	"& !Z& "Z!H
G!\$	"1#'1)'%""	DQE 4A	!	G#S	"1#'1)S1""	>E2= 4A	"!< & "Z!H
G!%	"1#'1)'%""	DQE 4A	!	G#%	"1#'1)#1""	>E2= 4A	"< & "Z!H
G!&	"1#'1)#1""	>E2= 4A	%Z< & "Z!H	G#&	"1#'1)S1""	>E2= 4A	#< & "Z!H
G!'	"1#'1)#1""	>E2= 4A	%Z< & "Z!H	G#'	"1#'1)%1""	>E2= 4A	%< & "Z!H
G!("1#'1)#1""	>E2= 4A	%Z< & "Z!H	G#("1#'1)S1""	>E2= 4A	"!< & "Z!H
G!)	"1#'1)#1""	>E2= 4A	%Z< & "Z!H	G#*	"1#'1)'%""	DQE 4A	!
G##	"1#'1)%&""	>E2= 4A	"!!< & "Z!H	G#!	"1#'1)'%""	DQE 4A	!
G#&	"1#'1)'%""	DQE 4A	!	G#&!	"1#'1)!*1"	GD4A	%< & "Z!H
G##	"1#'1)!*1""	>E2= 4A	"!! & "Z!H	G#&"	"1#'1)!%1""	GD4A	"< & "Z!H
G##	"1#'1)'%""	DQE 4A	!	G#&#	"1#'1)!%1""	GD4A	"< & "Z!H
G#\$	"1#'1)'%""	DQE 4A	!	G#&S	"1#'1)!%1""	GD4A	"< & "Z!H
G##!	"1#'1)S1""	>E2= 4A	##< & "Z!H	G#&%	"1#'1)!*1"	GD4A	%< & "Z!H
G##"	"1#'1)S1""	>E2= 4A	"!< & "Z!H	G#&&	"1#'1)!%1""	GD4A	"< & "Z!H
G###	"1#'1)S1""	>E2= 4A	##< & "Z!H	G#&'	"1#'1)!(*!!	GD4A	")< & "Z!H
G##S	"1#'1)S1""	>E2= 4A	\$\$< & "Z!H	G#&("1#'1)!(*!!	GD4A	")< & "Z!H
G##%	"1#'1)S1""	>E2= 4A	\$\$< & "Z!H	G#&)	"1#'1)!*1""	>E2= 4A	"!! & "Z!H
G##&	"1#'1)S1""	>E2= 4A	"!< & "Z!H	G#&*	"1#'1)#&""	>E2= 4A	#Z# & "Z!H
G##'	"1#'1)#1""	>E2= 4A	%Z< & "Z!H	G#&"	"1#'1)S1""	>E2= 4A	##< & "Z!H
G##("1#'1)#1""	>E2= 4A	%Z< & "Z!H	G#&#	"1#'1)S&""	>E2= 4A	"& & "Z!H
G##)	"1#'1)#1""	>E2= 4A	"< & "Z!H	G#&%	"1#'1)#1""	>E2= 4A	#Z< & "Z!H
G##*	"1#'1)#1""	>E2= 4A	"< & "Z!H	G#&&	"1#'1)S1""	>E2= 4A	"!< & "Z!H
G##"	"1#'1)#&""	>E2= 4A	#Z# & "Z!H	G#&'	"1#'1)%&""	>E2= 4A	"!!< & "Z!H
G##S	"1#'1)#1""	>E2= 4A	"< & "Z!H	G#&("1#'1)'%""	DQE 4A	!
G##%	"1#'1)"(1""	>E2= 4A	%! & "Z!H	G#&)	"1#'1)!*1!"	GD4A	##< & "Z!H
G##'	"1#'1)#&""	>E2= 4A	#Z# & "Z!H	G#&*	"1#'1)%&""	>E2= 4A	"!!< & "Z!H
G##("1#'1)"(1""	>E2= 4A	%! & "Z!H	G#&#	"1#'1)%&""	>E2= 4A	"!!< & "Z!H
G##)	"1#'1)#&""	>E2= 4A	#Z# & "Z!H	G#&#	"1#%1)#1#	>E2= 4A	%Z & "H
G###	"1#'1)'%""	DQE 4A	!	G#&##	"1#%1)#1#	>E2= 4A	%Z & "H
G###	"1#'1)'%""	DQE 4A	!	G#&S	"1#'1)%1""	>E2= 4A	%< & "Z!H
G\$!	"1#'1)#1""	>E2= 4A	"< & "Z!H	G#&%	"1#'1)'%""	DQE 4A	!
G\$"	"1#'1)#1""	>E2= 4A	"< & "Z!H	G#&&	"1#'1)#1""	>E2= 4A	"< & "Z!H
G\$#	"1#'1)!&""	>E2= 4A	% & "Z!H	G#&#	"1#'1)#&""	>E2= 4A	#Z# & "Z!H
G\$\$	"1#'1)!&""	>E2= 4A	% & "Z!H	G#!#	"1#)1)(*1""	>E2= 4A	##< !Z& "Z!H
G\$%	"1#'1)#1""	>E2= 4A	"< & "Z!H	G!\$	"1#)1)S1""	>E2= 4A	#! !Z& "Z!H
G\$&	"1#'1)#1""	>E2= 4A	"< & "Z!H	G!("1#)1)(*1""	>E2= 4A	##< !Z& "Z!H
G\$'	"1#'1)S1""	>E2= 4A	##< & "Z!H	G&""	"1#'1)S1""	>E2= 4A	##< & "Z!H

Note : The components identified by shading and marked Δ are critical for safety. Replace only with the part numbers specified in the parts list.

CSZ@	ARCE@	56DCAE@	CSZ<
C##S	"1#')%l"	>E2= 49 A	"#< & "z!H
C##%	"1#')l((l"	>E2= 49 A	")< !Z& "z!H
C##&	"1#')l("l"	>E2= 49 A	"!< !Z& "z!H
C##	"1#')l)S"	>E2= 49 A	"!< & "z!H
C##("1#')l)*l"	>E2= 49 A	"&< !Z& "z!H
C##)	"1#')l)S"	>E2= 49 A	"!< & "z!H
C##*	"1#')l)%&"	>E2= 49 A	"!!< & "z!H
C##S	"1#')l)%&"	>E2= 49 A	"!!< & "z!H
C##\$	"1#')l)(*l"	>E2= 49 A	##< !Z& "z!H
C###	"1#')l)%&"	DCE 49 A	!
C##)	"1#')l)%&"	DCE 49 A	!
C##%	"1#')l)%l"	>E2= 49 A	"< !Z& "z!H
C##%	"1#')l)S!"	>E2= 49 A	%! !Z& "z!H
C##%	"1#')l)%&"	DCE 49 A	!
C##%	"1#')l)%l"	>E2= 49 A	%< & "z!H
C##%	"1#')l)%l"	>E2= 49 A	%< & "z!H
Q!!&	"1#')l)!*l"	>E2= 49 A	"!! & "z!H
Q!!("1#')l)!*l"	>E2= 49 A	"!! & "z!H
Q!!)	"1#')l)!*l"	>E2= 49 A	"!! & "z!H
Q!!*	"1#')l)!*l"	>E2= 49 A	"!! & "z!H
Q!!!	"1#')l)!*l"	>E2= 49 A	"!! & "z!H
Q!!"	"1#')l)!*l"	>E2= 49 A	"!! & "z!H
Q!!#	"1#')l)!*l"	>E2= 49 A	"!! & "z!H
Q!!S	"1#')l)!*l"	>E2= 49 A	"!! & "z!H
Q!!%	"1#')l)!*l"	>E2= 49 A	"!! & "z!H
Q!!&	"1#')l)!*l"	>E2= 49 A	"!! & "z!H
Q!!"	"1#')l)!*l"	>E2= 49 A	"!! & "z!H
Q!!("1#')l)!*l"	>E2= 49 A	"!! & "z!H

- 4CDE2= /

I##!! "l('l' #l)" G3ZRCQ 4CDE2=

2 3 `RcU GRcZR_e ARced <G#)7B)' 3l <G!\$#7B)' 3

- EF76C /

HF"!!!)l&)!S&# 7C@E65 3E7 67%"

2 3 `RcU GRcZR_e ARced <G#)7B)' 6l <G!\$#7B)' 6z<

- EF76C /

HF"!!!)l&)!S!" 7C@E65 3E7 64%"

2 3 `RcU GRcZR_e ARced <G!\$#7B)' F

- EF76C /

HF"!!!)l&)!S!" 7C@E65 3E7 6F%"

CSZ@	ARCE@	56DCAE@	CSZ<
------	-------	---------	------

fi 2l"\$!#l*'\$l2 8 3 `RcU 4 ` ^ajVeV

%S #) &#!" DCGHl>S)/L ALDHlf

- 4A24RC /

4!!"	"l" &#)l"	>J=Z	!ZF7	"! #(&
4!!#	"l" &#)l"	>J=Z	!ZF7	"! #(&
4!!S	"l"*l*!l&	4C2: 4	##!A7	#Z!" #&G
4!!%	"l"*l*!l&	4C2: 4	##!A7	#Z!" #&G
4!!&	"l"#l* &*"	6-6E	##F7	#Z!" &G

4!!'	"l"(l(&l"	6-6E 3@/	%!F7	#Z!" %&G
4!!("l"#l* %&"	6-6E	"!F7	#Z!" &G
4!!)	"l"#l* \$"	6-6E	%ZF7	#Z!" &G
4!!!	"l"\$l%(l)"	7=>	!ZF7	Z!" &G
4!!"	"l"#l* %&"	4C2: 4 49 A!	Z!"F7	"!Z!" &G

4!!#	"l"!%&"l*"	4C2: 4	!Z!"&F7	"!Z!" #G
4!!S	"l"!%&"l*"	4C2: 4	!Z!"&F7	"!Z!" #G
4!!&	"l" &S\$l"	4C2: 4 49 A!	ZF7	"!Z!" &G
4!!"	"l"!%&"l*"	4C2: 4	!Z!"&F7	"!Z!" #G
4!!("l"!%&"l*"	4C2: 4	!Z!"&F7	"!Z!" #G

4!!")	"l"#l*%&l"	6-6E	##F7	#Z!" S&G
4!!**	"l"#l*)l"	4C2: 4 49 A!	Z!"%F7	"!Z!" &G
4!!#	"l"!!l\$"l"	7=>	##!!A7	\$)!IG
4!!#	"l" %& #&"	4C2: 4)!A7	"!Z!" &!G
4!!##	"l"#l* \$"	6-6E	%ZF7	#Z!" &G

4!!#S	"l"!!l' #l"	6-6E	SSF7	#Z!" ""!G
4!!#	"l" #l &#l"	6-6E	%!F7	#Z!" #&G
4!!#	"l"#l*\$l"	6-6E	"!!!F7	#Z!" ""G
4!!S	"l"#l*%&l"	6-6E	SSF7	#Z!" #&G
4!!S	"l"#l*%&l"	6-6E	SSF7	#Z!" #&G

4!!#	"l" \$*#(l"	4C2: 4	!Z!"F7	#&G
4!!SS	"l"#l* %&"	4C2: 4 49 A!	Z!"F7	"!Z!" &G
4!!S%	"l"#l*%&l"	6-6E	##F7	#Z!" S&G
4!!S&	"l"\$l%(l)"	7=>	!ZF7	Z!" &G
4!!S	"l"\$l%*l"	7=>	!Z!"F7	Z!" ""!G

4!!S	"l"#l*%&l"	6-6E	%F7	#Z!" S&G
4!!S	"l" %& #&"	4C2: 4)!A7	"!Z!" &!G
4!!S*	"l" #&)*l"	4C2: 4 49 A!	Z!F7	"!Z!" !G
4!!%	"l"#l(" &*"	4C2: 4 49 A!	Z##F7	"! ""G
4!!#	"l"#l*(l"	4C2: 4 49 A!	Z"F7	"!Z!" #&G

4!!%	"l" #&)*l"	4C2: 4 49 A!	Z!F7	"!Z!" !G
4!!&	"l" &S\$l"	4C2: 4 49 A!	ZF7	"!Z!" &G
4!!\$	"l"*l*%&l&	6-6E	%!F7	#Z!" &G

- 4@?6RC /

4!!"	"fi"l"*l*#l"	A 7L 4@?6RC	1A4 3QC5	&A
4!!#	"fi"l&)!l"!!	A 7L 4@?6RC	1&> AE49	#A
4!!S	"fi"l&)!(&!!	A 7L 4@?6RC	1&> AE49	SA
4!!%	"fi"l"*l*!l"	A 7L 4@?6RC	1A4 3QC5	SA
4!!&	"fi"l"(!l\$!"	A 7L 4@?6RC	'A	

Note : The components identified by shading and marked Δ are critical for safety. Replace only with the part numbers specified in the parts list.

65Z@Z	A2CEZ@	56DCAE@	6B-2C<	65Z@Z	A2CEZ@	56DCAE@	6B-2C<
4!!'	fi "1&%&1!"	AFL 4@76EC (A					- EC2DDE@ /
4!!("1)"(1*(1"	A 7L 4@76EC SA		B!!S)1(#1!"1#	EC2DDE@ >D5!"1CE	
4!!)	fi "1)"1*(1&	AFL 4@76EC' A		B!!&)1(#1*"1!"	EC2DDE@ 5E2'%6<	
4!"#	fi "1&%&1!"	AFL 4@76EC (A		B!!'	'1&&1'*)1!"	EC2DDE@ DA2)?&410"&	
	- 5@6/			B!!('1&&1'*)1!"	EC2DDE@ DA2)?&410"&	
				B!!")1(#1!"1#	EC2DDE@ >D5!"1CE	
5!!"	'1&1!"(1"	5 @6 8D3%!=2&		B!"#)1(#1!"1#	EC2DDE@ >D5!"1CE	
5!!#)1("1*)##	5 @6 >EK1SS					- 6DDE@ /
5!!%)1("1!)\$*%	5 @6 7F7!&		;C!!("1#1)"%'"	D9CE 49A !	
5!!')1("1!)1*(5 @6 >>5*"0E		C!!S	' "1##*SS'"	7D3-6 !Z "!" "z#H	
5!!()1("1!)1*(5 @6 >>5*"0E		C!!%	' "1#&**"1"	466E5 " & "!"H	
				C!!&	' "1#&**"1"	466E5 " & "!"H	
5!!)	'1&1!"(&"	5 @6 "61E3		C!!("1#&*(1#	>E2 @:56 !Z & #H	
5!!*)1("1!"1!"	5 @6 C5 8D#		C!!)	"1#&*(1#	>E2 @:56 !Z & #H	
5!"#)1("1!&#!	5 @6 5'?=>81E2#		C!!*	"1#)1)(&"	>E2 49A "& !Z& "z!"H	
5!"\$	'1&1!"(&"	5 @6 "61E3		C!"!	"1#&%)1#	>E2 %!< "" "z#H	
5!"')1("1!"1!"	5 @6 56D		C!""	"1#&%%)1#	>E2 #Z# # "z#H	
				C!"#	"1#&%%)1#	>E2 #Z# # "z#H	
5!"()1("1!&#!	5 @6 5'?=>81E2#		C!"\$	' "1#)1#&"	>E2)Z# & "H	
5!\$)1("1!)1!&	5 @6 6"*1G		C!"%	"1#&' #1#	>E2 @:56 SS< & SH	
5!#)1("1!)1!&	5 @6 6"*1G		C!"&	"1#"1**#"1"	>E2 49A "*" !Z& "z!"H	
5!\$\$)1("1\$#*#	5 @6 C">G		C!""	"1#"1)1#1"	>E2 49A "< & "z!"H	
5!\$%)1("1\$#*#	5 @6 C">G		C!"("1#"1)SS"	>E2 49A "!"< & "z!"H	
				C!")	"1#"1)"S1"	4C3@ %!< & "z#H	
5!\$)1("1!)1!&	5 @6 6"*1G		C!"*	"1#"1)"#1"	4C3@ SS< & "z#H	
5!"#)1("1&"1%	5 @6 DC3%		C!#	"1#"1)1#1"	>E2 49A)# & "z!"H	
5!"%)1("1!)1*(5 @6 >>5*"0E		C!#	"1#&*"%)1#	>E2 @:56 !Z# & #H	
5!"&)1("1!)1*(5 @6 >>5*"0E		C!##	"1#"1)SS"	>E2 49A "!"< & "z!"H	
				C!#%	"1#"1*)1"	>E2 49A SS !Z& "z!"H	
	- 7CCB335 /			C!#	"1#"1)SS"	>E2 49A "!"< & "z!"H	
73!!#	"1%1\$*(1#	7CCB	"Z!F9	C!\$	"1#"1)"(1"	>E2 49A %! & "z!"H	
73!!\$	"1%1\$*(1#	7CCB	"Z!F9	C!\$#	"1#&1%(1"	4C3@ "< & "z#H	
	- :4/			C!\$\$	"1#&%)1#	>E2 %!< "" "z#H	
:4!!")1(&1)"1\$:4 >4S!"5		C!\$\$	"1#&%)1#	>E2 %!< "" "z#H	
:4!!\$)1(%1!"1"*	:4 D' S&1=7%		C!\$&	"1#"1!)1\$"	4C3@ % & "z#H	
	- 4@=/			C!\$	"1#"1)"(1"	>E2 49A %! & "z!"H	
=!!"	"1%1'" \$#	:?F4EC %F9		C!\$#	"1#&1%(1"	4C3@ "< & "z#H	
=!!#	"1%#\$:?F4EC %Z!F9		C!\$\$	"1#&%)1#	>E2 %!< "" "z#H	
=!!\$	"1%#\$:?F4EC %Z!F9		C!\$&	"1#"1!)1\$"	4C3@ % & "z#H	
=!!%	"1&&1\$1\$!!	=6ZL ; F>ACC 1&Z>/		C!\$	"1#"1)"(1"	>E2 49A %! & "z!"H	
=!!&	"1&&1\$1\$!!	=6ZL ; F>ACC 1&Z>/		C!\$	"1#&1%&"	4C3@ "!" & "z#H	
				C!\$	"1#"1)*&"	>E2 49A "!"< !Z& "z!"H	
=!!'	"1%1' &1"	:?F4EC "!"F9		C!\$*	"1#"1)*&"	>E2 49A "!"< !Z& "z!"H	
=!!("1%#\$:?F4EC "!"F9		C!%&	"1#"1)*1"	>E2 49A ##< !Z& "z!"H	
=!!)	"1%#\$:?F4EC %F9		C!%&	"1#"1)"&"	>E2 49A SS & "z!"H	
=!!*	"1%%"1"	:?F4EC %Z!F9		C!%&	"1#"1))&"	>E2 49A \$*< !Z& "z!"H	
=!!%	"1%%"1\$:?F4EC "!"F9		C!%&	"1#"1)*1"	>E2 49A)Z# !Z& "z!"H	
				C!&	"1#"1)1\$"	>E2 49A "!" !Z& "z!"H	
	- A@C@FA-C /			C!&	"1#"1)*1"	>E2 49A SS !Z& "z!"H	
A9!!" ' "1!"1!"(1!"	A@C@FA-C A1 #S##, @7			C!&	"1#"1)1#1"	>E2 49A %Z< & "z!"H	
				C!"!	"1#"1)1#1"	>E2 49A "< & "z!"H	
				C!"#	"1#"1)1#1"	>E2 49A %Z< & "z!"H	

ČZ	ACEZ@	5DCAE@	ČZ<	ČZ	ACEZ@	5DCAE@	ČZ<
4S&	"1"%"&1"	4C2: 4 49A!ŽF7	#&	4&&! "	"1"#{("&*" 4C2: 4 49A!Ž#F7	"!" "G	
4S'	"1"%"&1"	4C2: 4 49A!ŽF7	#&				
4S("1"#{1*%&1"	6-6E %F7	#Ž!" S&		- 4@?6E@/		
4S)	"1"%"&1"	4C2: 4 49A!ŽF7	#&				
4S*	"1"%"&1"	4C2: 4 49A!ŽF7	#&	4S!!	"1(*%#%&1"	4@?6E@L 5? 1AF8' *' A	
				4S%!	fi "1&%&#%&1"	AFB 4@?6E@*A	
				4S%#	fi "1&%"	AFB 4@?6E@%A	
4S!	"1"%"&1"	4C2: 4 49A!ŽF7	#&				
4S"	"1"%"&1"	4C2: 4 49A!ŽF7	#&				
4S#	"1" #*#1"	4C2: 4 49A##A7	Ž!" &G		- 5 @6/		
4S\$	"1" #*#1"	4C2: 4 49A##A7	Ž!" &G				
4S%	"1"%"&1"	4C2: 4 49A!ŽF7	#&	5!'*)1("1!)\$&	5 @6 F3D6"(\$Ž 3	
				5!(!)1("1!)1*(5 @6 >5=*%E	
				5!()1("1!)1*(5 @6 >5=*%E	
4S&	"1"%"&1"	4C2: 4 49A!ŽF7	#&	5&&!)1("1!' 1&&	5 @6 F3D6"(\$Ž 3	
4S'	"1"%"&1"	4C2: 4 49A!ŽF7	#&	5&&")1("1!)\$&	5 @6 F3D6"(\$Ž 3	
4S("1"%"&1"	4C2: 4 49A!ŽF7	#&				
4S)	"1"%"&1"	4C2: 4 49A!ŽF7	#&				
4S*	"1"#{1*%&1"	6-6E %F7	#Ž!" S&	5&&#	'1&!!#1!"	5 @6 >S*KGE	
				5&&%)1("1!)1*(5 @6 >5=*%E	
4S#	"1"#{1*%&1"	6-6E %F7	#Ž!" S&	5&&&)1("1!)1*(5 @6 >5=*%E	
4S#	"1"%"&1"	6-6E %F7	#Ž!" "G	5&&')1("1!)1*(5 @6 >5=*%E	
4S#%	"1"%"&1"	4C2: 4 49A!ŽF7	#&	5&&")1("1!)1*(5 @6 >5=*%E	
4S%#	"1"#{1*%&1"	6-6E %F7	#Ž!" S&				
4S%S	"1"%"&1"	4C2: 4 49A!ŽF7	#&		- :4/		
				:4!!"	'1(!%*' %!"	:4 D2!!"13#E	
4S&	"1"%"&1"	4C2: 4 49A!ŽF7	#&	:4!!#)1(&1')#%	:4 >#4S#H? E2	
4S'	"1"#{1*%&1"	6-6E %F7	#Ž!" S&	:4!!\$	'1(!%\$'#!"	:4 <D%' \$#7F4&E	
4S("1"%"&1"	4C2: 4 49A!ŽF7	#&	:4!!&	'1)!%#(1!#	:4 >#(G' 1!"!<' J!!#	
4S)	"1"#{1*%&1"	6-6E %F7	#Ž!" S&	:4!!'	'1(!#S\$!"	:4 AE!!: -E	
4S*	"1"#{1*%&1"	6-6E %F7	#Ž!" S&				
				:4!!()1(&1 \$"	:4 AE*"%\$=	
4S!	"1"%"&1"	4C2: 4 49A!ŽF7	#&	:4S!!	'1)!\$!"	:4 CA*%(348	
4S"	"1"%"&1"	4C2: 4 49A!ŽF7	#&	:4S!	'1(!&'#%!"	:4 7C4*#22	
4S#	"1"!(1)#1"	4C2: 4 49A!ŽF7	"!Ž!" "G	:4S%	'1(!&'#S!"	:4 55AS" 49&	
4S\$	"1"%"&1"	4C2: 4 49A!ŽF7	#&				
4S%	"1"!(1)#1"	4C2: 4 49A!ŽF7	"!Ž!" "G				
					- 4@=/		
4S#	"1"!(1)#1"	4C2: 4 49A!ŽF7	"!Ž!" "G	≠!!#	"1%%*#)1#	:?F4E@ "F9	
4S#&	"1"%"&1"	4C2: 4 49A!Ž%F7	"!Ž!" "G	≠!!\$	"1%%*#)1#	:?F4E@ "F9	
4S#'	"1"%"&1"	4C2: 4 49A!Ž%F7	"!Ž!" "G	≠!!%	"1%%*#)1#	:?F4E@ "F9	
4S#("1"%"&1"	4C2: 4 49A!Ž%F7	"!Ž!" "G	≠!!'	"1%%*#)1#	:?F4E@ "F9	
4S#)	"1"%"&1"	4C2: 4 49A!Ž%F7	"!Ž!" "G	≠!!("1%%*#)1#	:?F4E@ "F9	
4S#*	"1"#{1*%&1"	6-6E %F7	#Ž!" S&	≠!!)	"1%%*#)1#	:?F4E@ "F9	
				≠\$!!	"1%%*#)1#	:?F4E@ "F9	
4S#%	"1"%"&1"	4C2: 4 49A!Ž%F7	#&	≠\$!%	"1%%*#)1#	:?F4E@ "F9	
4S#&	"1"!(1)#1"	4C2: 4 49A!ŽF7	"!Ž!" "G	≠\$!&	"1%%*#)1#	:?F4E@ "F9	
4S#'	"1"#{1*%&1"	6-6E %F7	#Ž!" S&	≠\$!'	"1%%*#)1#	:?F4E@ "F9	
				≠\$!("1%%*#)1#	:?F4E@ "F9	
4S!	"1"%"&1"	4C2: 4 49A!ŽF7	#&	≠\$\$!	"1%%*#)1#	:?F4E@ "F9	
4S"	"1" #*#(1)"	4C2: 4 49A!!A7	Ž!" &G	≠\$\$"	"1%%*#)1#	:?F4E@ "F9	
4S("1" #*#(1)"	4C2: 4 49A!Ž"F7	"!Ž!" #&	≠\$\$ #	"1%%*#)1#	:?F4E@ "F9	
4S)	"1" #*#(1)"	4C2: 4 49A!Ž"F7	"!Ž!" #&	≠\$\$ \$	"1%!1\$(1#	7C B "ŽF9	
4S*	"1" #*#(1)"	4C2: 4 49A!Ž"F7	"!Ž!" #&				
4S#	"1"%"&1"	4C2: 4 49A!Ž!F7	Ž!" #&	≠\$%!	"1%%*#)1#	:?F4E@ "F9	
4S%	"1" #*#(1)"	4C2: 4 49A!!A7	Ž!" &G	≠\$%"	"1%%*#)1#	:?F4E@ "F9	
4S&	"1" #*#(1)"	4C2: 4 49A!Ž"F7	"!Ž!" #&	≠\$%#	"1%%*#)1#	:?F4E@ "F9	
4S'	"1" #*#(1)"	4C2: 4 49A!Ž"F7	"!Ž!" #&	≠\$%\$	"1%%*#)1#	:?F4E@ "F9	
4S("1"%"&1"	4C2: 4 49A!ŽF7	#&				
4S)	"1"%"&1"	4C2: 4 49A!ŽF7	#&				
4S*	"1"#{1*%&1"	6-6E %F7	#Ž!" S&				

С6Ž@	АХЕЖ@	56DCAE@	С6-2<	С6Ž@	АХЕЖ@	56DCAE@	С6-2<
=S%&	"1%*#1#	:?F4R@	"F9	С!!*	"1#1)"(1"	ХЕ2 49A	%! & "ž!H
=88&	"1%*#1#	:?F4R@	"F9	С!""	"1#1)'%"	Д90E 49A	!
	- K2DDE@/			С!%"	"1#1)!&"	ХЕ2 49A	% & "ž!H
B!!")1(#1!"1!&	K2DDE@>D!*"1CE		С!"&	"1#1)!&"	ХЕ2 49A	% & "ž!H
B!!#)1(#1!"1!&	K2DDE@>D!*"1CE		С!!"	"1#1)!&"	ХЕ2 49A	% & "ž!H
B!!\$)1(#1!"1!&	K2DDE@>D!*"1CE		С!"("1#1)'#1"	ХЕ2 49A	"< & "ž!H
B!!&)1(#1!"1!#	K2DDE@>D!"1CE		С!")	"1#1)'%"	Д90E 49A	!
B!(&)1(#1!"1!#	K2DDE@>D!"1CE		С!"*	"1#1)!*1"	ХЕ2 49A	"!! & "ž!H
				С!#	"1#1)'S"	ХЕ2 49A	"!< & "ž!H
				С!#	"1#1)!*1"	ХЕ2 49A	"!! & "ž!H
B\$!)1(#1!"1!#	K2DDE@>D!"1CE		С!##	"1#1)'%"	Д90E 49A	!
B\$")1(#1!"1!#	K2DDE@>D!"1CE		С!#\$	"1#1)'S"	ХЕ2 49A	"!< & "ž!H
B\$#)1(#1!"1!#	K2DDE@>D!"1CE		С!#&	"1#1)!*1"	ХЕ2 49A	"!! & "ž!H
B\$S)1(#1!"1!#	K2DDE@>D!"1CE		С!#	"1#1)!*1"	ХЕ2 49A	"!! & "ž!H
B\$%)1(#1!"1!#	K2DDE@>D!"1CE		С!#("1#1)!*1"	ХЕ2 49A	"!! & "ž!H
B\$&)1(#1!"1!#	K2DDE@>D!"1CE		С!#)	"1#1)'S"	ХЕ2 49A	"!< & "ž!H
B\$')1(#1!"1!&	K2DDE@>D!*"1CE		С!#*	"1#1)!*1"	ХЕ2 49A	"!! & "ž!H
B\$*)1(#1!"1!#	K2DDE@>D!"1CE		С!#\$	"1#1)!*1"	ХЕ2 49A	"!! & "ž!H
B\$!)1(#1!"1!#	K2DDE@>D!"1CE		С!\$	"1#1)!*1"	ХЕ2 49A	"!! & "ž!H
B&!)1(#1!"1!#	K2DDE@>D!"1CE		С!\$S	"1#1)!*1"	ХЕ2 49A	"!! & "ž!H
				С!\$#	"1#1)'#1"	ХЕ2 49A	SŽ & "ž!H
B&S)1(#1!"1!#	K2DDE@>D!"1CE		С!\$\$	"1#1)'#1"	ХЕ2 49A	SŽ & "ž!H
B&&)1(#1!"1!#	K2DDE@>D!"1CE		С!\$%	"1#1)'#&"	ХЕ2 49A	#Ž# & "ž!H
B&()1(#1!"1!&	K2DDE@>D!*"1CE		С!\$&	"1#1)!*1"	ХЕ2 49A	"!! & "ž!H
B&*)1(#1!"1!#	K2DDE@>D!"1CE		С!\$S	"1#1)!*1"	ХЕ2 49A	"!! & "ž!H
B&*)1(#1!"1!#	K2DDE@>D!"1CE		С!\$S	"1#1)!*1"	ХЕ2 49A	"!! & "ž!H
				С!\$S	"1#1)'#1"	ХЕ2 49A	SŽ & "ž!H
B&#)1(#1!"1!&	K2DDE@>D!*"1CE		С!\$%	"1#1)'#&"	ХЕ2 49A	#Ž# & "ž!H
B&&)1(#1!"1!#	K2DDE@>D!"1CE		С!\$&	"1#1)!*1"	ХЕ2 49A	"!! & "ž!H
	- 6DDE@/			С!\$	"1#1)!*1"	ХЕ2 49A	"!! & "ž!H
				С!\$	"1#1)!*1"	ХЕ2 49A	"!! & "ž!H
С!!#	"1#1)'%"	Д90E 49A	!	С!\$S	"1#1)'#1"	ХЕ2 49A	SŽ & "ž!H
С!!\$	"1#1)'%"	Д90E 49A	!	С!\$%	"1#1)'#&"	ХЕ2 49A	#Ž# & "ž!H
С!!%	"1#1)'%"	Д90E 49A	!	С!\$&	"1#1)!*1"	ХЕ2 49A	"!! & "ž!H
С!!)	"1#1)'%"	Д90E 49A	!	С!\$S	"1#1)!*1"	ХЕ2 49A	"!! & "ž!H
С!!!"	"1#1)'%"	Д90E 49A	!	С!\$S	"1#1)!*1"	ХЕ2 49A	"!! & "ž!H
				С!\$S	"1#1)'#1"	ХЕ2 49A	SŽ & "ž!H
С!!""	"1#1)'%"	Д90E 49A	!	С!\$%	"1#1)'#&"	ХЕ2 49A	#Ž# & "ž!H
С!\$!	"1#1)'%"	Д90E 49A	!	С!\$&	"1#1)!*1"	ХЕ2 49A	"!! & "ž!H
С!\$"	"1#1)'%"	Д90E 49A	!	С!\$S	"1#1)!*1"	ХЕ2 49A	"!! & "ž!H
С!\$%	"1#1)'%"	Д90E 49A	!	С!\$S	"1#1)!*1"	ХЕ2 49A	"!! & "ž!H
С!\$'	"1#1)'%"	Д90E 49A	!	С!\$S	"1#1)'#1"	ХЕ2 49A	SŽ & "ž!H
				С!\$S	"1#1)'#&"	ХЕ2 49A	#Ž# & "ž!H
С!\$)	"1#1)'%"	Д90E 49A	!	С!\$%	"1#1)'#&"	ХЕ2 49A	#Ž# & "ž!H
С!\$*	"1#1)'%"	Д90E 49A	!	С!\$&	"1#1)!*1"	ХЕ2 49A	"!! & "ž!H
С!\$#	"1#1)'%"	Д90E 49A	!	С!\$S	"1#1)!*1"	ХЕ2 49A	"!! & "ž!H
				С!\$S	"1#1)'#1"	ХЕ2 49A	SŽ & "ž!H
С!!"	"1#1)'S"	ХЕ2 49A	"!< & "ž!H	С!\$S	"1#1)'#&"	ХЕ2 49A	#Ž# & "ž!H
С!!#	"1#1)'S"	ХЕ2 49A	"!< & "ž!H	С!\$%	"1#1)'#&"	ХЕ2 49A	#Ž# & "ž!H
С!!\$	"1#1)'S"	ХЕ2 49A	"!< & "ž!H	С!\$&	"1#1)!*1"	ХЕ2 49A	"!! & "ž!H
С!!%	"1#1)'1"	ХЕ2 49A	\$! & "ž!H	С!\$S	"1#1)!*1"	ХЕ2 49A	"!! & "ž!H
С!!&	"1#1)'1"	ХЕ2 49A	\$! & "ž!H	С!\$S	"1#1)'#1"	ХЕ2 49A	SŽ & "ž!H
				С!\$S	"1#1)'#&"	ХЕ2 49A	#Ž# & "ž!H
С!!'	"1#1)'1"	ХЕ2 49A	\$! & "ž!H	С!\$%	"1#1)'#&"	ХЕ2 49A	#Ž# & "ž!H
С!!("1#1)'(1"	ХЕ2 49A	%! & "ž!H	С!\$&	"1#1)!*1"	ХЕ2 49A	"!! & "ž!H
С!!)	"1#1)'(1"	ХЕ2 49A	%! & "ž!H	С!\$S	"1#1)!*1"	ХЕ2 49A	"!! & "ž!H

СЗЩ	АЩ@	ЩА@	СЩ	СЗЩ	АЩ@	ЩА@	СЩ
С!("\#\#)"!*"	ЩА	!! & "З!Н	СS("\#\#)"%'	ЩА !	
С!("\#\#)"%#"	ЩА	##< & "З!Н	СS)	"\#\#)"%'	ЩА !	
С!(#	"\#\#)"#\#"	ЩА	%< & "З!Н	СS"	"\#\#)"%'	ЩА !	
С!(S	"\#\#)"SS"	ЩА	"!< & "З!Н	СS%"	"\#\#)"#\#"	ЩА "< & "З!Н	
С!(%)	"\#\#)"%'	ЩА !		СS&	"\#\#)"#\#"	ЩА "< & "З!Н	
С!(&	"\#\#)"!*"	ЩА	!! & "З!Н	СS"	"\#\#)"#\#"	ЩА "< & "З!Н	
С!("\#\#)"%'	ЩА !		СS("\#\#)"#\#"	ЩА "< & "З!Н	
С!(*	"\#\#)"%'	ЩА !		СS)	"\#\#)"#\#"	ЩА "< & "З!Н	
С!(!	"\#\#)"#\#"	ЩА	ЩЩ & "З!Н	СS*	"\#\#)"#\#"	ЩА "< & "З!Н	
С!("\#\#)"#\#"	ЩА	ЩЩ & "З!Н	СS#	"\#\#)"#\#"	ЩА "< & "З!Н	
С!)#	"\#\#)"!*"	ЩА	!! & "З!Н	СS#	"\#\#)"#\#"	ЩА "< & "З!Н	
С!)S	"\#\#)"!*"	ЩА	!! & "З!Н	СS#("\#\#)"(!"	ЩА %! & "З!Н	
С!)%	"\#\#)"SS"	ЩА	"!< & "З!Н	СS!	"\#\#)"%'	ЩА !	
С!)&	"\#\#)"#\#"	ЩА	%< & "З!Н	СS"	"\#\#)"#\#"	ЩА "< & "З!Н	
С!)'	"\#\#)"!*"	ЩА	!! & "З!Н	СS\$	"\#\#)"\$!"	ЩА ')! !ЩЩ "З!Н	
С!)("\#\#)"!*"	ЩА	!! & "З!Н	СS&	"\#\#)"(*!"	ЩА "! & "З!Н	
С!)#	"\#\#)"!*"	ЩА	!! & "З!Н	СS'	"\#\#)"%'	ЩА !	
С!)*	"\#\#)"#\#"	ЩА	ЩЩ:4ЩА !ЩЩ!"	СS)	"\#\#)"(*!"	ЩА "! & "З!Н	
С!#	"\#\#)"#\#"	ЩА	%< & "З!Н	СS*	"\#\#)"%'	ЩА !	
С!\$	"\#\#)"SS"	ЩА	"!< & "З!Н	СS!	"\#\#)"(*!"	ЩА "! & "З!Н	
С!*&	"\#\#)"#\#"	ЩА	"< & "З!Н	СS#	"\#\#)"%'	ЩА !	
С!**	"\#\#)"SS"	ЩА	"!< & "З!Н	СS\$	"\#\#)"%'	ЩА !	
С"!#	"\#\#)"%'	ЩА !		СS%	"\#\#)"!*"	ЩА "!! & "З!Н	
С"!)	"\#\#)"%'	ЩА !		СS&	"\#\#)"&&"	ЩА #ЩЩ !ЩЩ "З!Н	
С"\$	"\#\#)"S!"	ЩА	SS & "З!Н	СS'	"\#\#)"S!"	ЩА \$! !ЩЩ "З!Н	
С!!	"\#\#)"%'	ЩА !		СS("\#\#)"&&"	ЩА #ЩЩ !ЩЩ "З!Н	
С!S	"\#\#)"%'	ЩА !		СS*	"\#\#)"(!"	ЩА %! & "З!Н	
С!%	"\#\#)"%'	ЩА !		СS#	"\#\#)"(!"	ЩА %! & "З!Н	
С!'	"\#\#)"%'	ЩА !		СS##	"\#\#)"!*"	ЩА "!! & "З!Н	
С!)	"\#\#)"%'	ЩА !		СS\$S	"\#\#)"(!"	ЩА %! & "З!Н	
С!*	"\#\#)"!*"	ЩА	!! & "З!Н	СS#("\#\#)"#\#"	ЩА)# & "З!Н	
С"!#	"\#\#)"!*"	ЩА	!! & "З!Н	СS#)	"\#\#)"#\#"	ЩА)# & "З!Н	
С"##	"\#\#)"!*"	ЩА	!! & "З!Н	СS#*	"\#\#)"#\#"	ЩА)# & "З!Н	
С"\$S	"\#\#)"!*"	ЩА	!! & "З!Н	СS%	"\#\#)"%'	ЩА !	
С"%	"\#\#)"%'	ЩА !		СS\$	"\#\#)"%'	ЩА !	
С"&	"\#\#)"%'	ЩА !		СS\$	"\#\#)"%'	ЩА !	
С"("	"\#\#)"%'	ЩА !		СS\$S	"\#\#)"\$!"	ЩА "< !ЩЩ "З!Н	
С" &	"\#\#)"&&"	ЩА	!!< & "З!Н	СS%%	"\#\#)"!*"	ЩА "!! & "З!Н	
С##	"\#\#)"%'	ЩА !		СS&&	"\#\#)"!*"	ЩА "!! & "З!Н	
С##	"\#\#)"%'	ЩА !		СS%	"\#\#)"!*"	ЩА "!! & "З!Н	
С###	"\#\#)"%'	ЩА !		СS%	"\#\#)"!*"	ЩА "!! & "З!Н	
С##S	"\#\#)"%'	ЩА !		СS&	"\#\#)"S!"	ЩА \$! !ЩЩ "З!Н	
С#("\#\#)"%'	ЩА !		СS&	"\#\#)"#\#"	ЩА %< & "З!Н	
С#"	"\#\#)"%'	ЩА !		СS#	"\#\#)"(!"	ЩА %! & "З!Н	
С#("\#\#)"%'	ЩА !		СS"	"\#\#)"#\#"	ЩА "< & "З!Н	
СS!	"\#\#)"!*"	ЩА	!! & "З!Н	С&&"	"\#\#)"#\#"	ЩА "< & "З!Н	
СS"	"\#\#)"!*"	ЩА	!! & "З!Н	С&&#	"\#\#)"!*"	ЩА "!! & "З!Н	
СS#	"\#\#)"%'	ЩА !		С&&\$	"\#\#)"#\#"	ЩА "< & "З!Н	
СS\$	"\#\#)"%'	ЩА !		С&&%	"\#\#)"!*"	ЩА "!! & "З!Н	
СS'	"\#\#)"%'	ЩА !		С&&&	"\#\#)"!*"	ЩА "!! & "З!Н	

G5ZQZ	ARCEZ@	56DCAE@	G6-Z<
4"#	"1"(1' #S	7=>	!Z)F7 & #&G
4"#	"1"(1)%1"	7=>	!ZF7 Š!~ %!G
4"##	"1" #*#1"	4C2: 4 4A"!A7	Š!~ &G
4"#%	"1"%##1"	4C2: 4 4A!Z##F7	"!Z!~ #&G
4"#&	"1" #*}1"	4C2: 4 4A!Z!%F7	"!Z!~ &G
4"#	"1" &('1"	4C2: 4 4A!Z%F7	"!Z!~ " G
4"#("1"(1S)1"	>J=Z !Z%F7	"!Z!~ #!G
4"#)	"1" #*}1"	4C2: 4 4A!Z!%F7	"!Z!~ &G
4"#*	"1"!#!S!!	4C2: 4 S!A7	"!Z!~ &!G
4"#S	"1"(1S)1"	>J=Z !Z%F7	"!Z!~ #!G
4"##	"1"%#S1"	4C2: 4 4A##A7	Š!~ &G
4"#%	"1"!#*S&!!	4C2: 4 #A7	!Z#A7 &G
4"#&	"1" #1* '1"	6-6E SF7	#Z!~ &G
4"#S	"1" #1* %"	6-6E !F7	#Z!~ &G
4"#S	"1"!#!S!!	4C2: 4 S!A7	"!Z!~ &!G
4"#*	"1" #S1"	4C2: 4 ##A7	"!Z!~ #G
4"%	"1"(1)S1"	7=>)!!A7 Š!~ "Z&G
4"%#	"1" #1' "1"	7=>	"!!!!A7 # "!!G
4"%S	"1" #&)*S"	7=>)!A7 Š!~ "Z&G
4"%%	"1" #&)*S"	7=>)!A7 Š!~ "Z&G
4"%	"1" #1*%1"	6-6E %F7	#Z!~ S&G
4"%%	"1"(1' #S	7=>	!Z)F7 & #&G
4#!	"1" &%1)"	6-6E SF7	#~ "!!G
4#"	"1"(1' &"	6-6E %F7	#Z!~ #&G
4"##	"1"!###)!!	4C2: 4 %!A7	"!Z!~ &!G
4"#S	"1"!###)!!	4C2: 4 %!A7	"!Z!~ &!G
4"#%	"1"!###)!!	4C2: 4 %!A7	"!Z!~ &!G
4"#&	"1" #1*%1"	6-6E %!F7	#Z!~ #&G
4#"'	"1" #1*%1"	6-6E %!F7	#Z!~ #&G
4#" ("1" #1* %"	6-6E !F7	#Z!~ &G
4#"*	"1" %S&"	4C2: 4 4A%!A7	Š!~ &G
4#"!	"1" #* %"	4C2: 4 4A!Z!"F7	"!Z!~ &G
4#"#	"1" %&1"	4C2: 4 4A!ZF7	#&G
4#"S	"1" %#S1"	4C2: 4 4A##A7	Š!~ &G
4#"S	"1" %&1"	4C2: 4 4A!ZF7	#&G
4#"#	"1" #1*%1"	6-6E %F7	#Z!~ S&G
4#"#%	"1" %&1"	4C2: 4 4A!Z!F7	#&G
4#"S	"1" S1%(1)"	7=>	!ZF7 Š!~ &G
4#"S	"1" S1S%1"	7=>	!Z!%F7 Š!~ 'SG
4#"S	"1" S1%*1"	7=>	!Z"&F7 Š!~ 'SG
4)!)#	"1" #1* !1"	6-6E "F7	#Z!~ &G
4)!)S	"1" #1* !1"	6-6E "F7	#Z!~ &G
4)!)%	"1"!#""%!!	4C2: 4 %!A7	"!Z!~ &G
4)!)&	"1"!#""%!!	4C2: 4 %!A7	"!Z!~ &G

- 4@?6E@/

4)!)%	fi "1&%&1!"	Af8 4@?6E@ (A
4)!)#S	"1" *1((&"	Af8 1>4@4@?6E@ "SA
4)!)#'	fi "1&%&1!"	Af8 4@?6E@ (A
4)!)#"	fi "1()&#(1)"#	A 7.5J 4@?6E@ 1A4 3@C5

G5ZQZ	ARCEZ@	56DCAE@	G6-Z<
4)!)&	"1" *1((S"	Af8 1>4@4@?6E@ ""A	
4)!)*!	fi "1&%&1!"	Af8 4@?6E@ (A	
- 5 @6 /			
5)!)!	"1&&S S!!	=6ZL; F>AC 1 Š!>>	
5)!)")1(" *1!"1%	5 @6 C5 &D#	
5)!)#)1(" *1!"1*(5 @6 >5-*%E	
5)!)S)1(" *1!"1*(5 @6 >5-*%E	
5)!)%)1(" *1!"1*(5 @6 >5-*%E	
5)!)&)1(" *1!"1*(5 @6 >5-*%E	
5)!)')1(" *1!"1*(5 @6 >5-*%E	
5)!) ()1(" *1!"1*(5 @6 >5-*%E	
5)!)))1(" *1*#1%	5 @6 >HK 1%Z 4	
5)!)#)1(" *1!"1*(5 @6 >5-*%E	
5)!)S#)1(" *1!"1*(5 @6 >5-*%E	
5)!)SS)1(" *1!"1*(5 @6 >5-*%E	
5)!)**)1(" *1!"1*(5 @6 >5-*%E	
5)!)#!)1(" *1S#%S	5 @6 6="K	
5)!)#")1(" *1S#%S	5 @6 6="K	
5)!)#S)1(" *1!)&"#	5 @6 3G)1#!1CD"&"#	
5)!)#%)1(" *1!)&"#	5 @6 3G)1#!1CD"&"#	
5)!)# ()1(" *1**1SS	5 @6 "DSSH((
5)!)#))1(" *1**1SS	5 @6 "DSSH((
5)!)&))1(" *1!' S(S	5 @6 5'?=#HEC	
5)!)&*)1(" *1!"1*(5 @6 >5-*%E	
5)!)'")1(" *1!"1*(5 @6 >5-*%E	
5)!)'"#)1(" *1!"1*(5 @6 >5-*%E	
5)!)!#)1(" *1!"1*(5 @6 >5-*%E	
5)!)!S)1(" *1!"1*(5 @6 >5-*%E	
- 7@C E6 365 /			
73)!)!	"1%!1S*(1#	7@C E6 "ZF9	
- :4/			
:4)!)!)1(&1' &"	:4=>S*SE	
:4)!)")1(&1' &"	:4=>S*SE	
:4)!)#)1(&1' S1(*	:4? >%%Z 1H	
:4)!)S)1(&1' &1' (:4=2 S*S=	
:4)!)#)1(&1' (!!"	:4? >#1%	
- 4@= /			
=>!)"	"1%1*)&"	:?F4E@ #Z#9	
=>!)#	"1%*%#)1#	:?F4E@ "F9	
=>!)S	"1%*%#)1#	:?F4E@ "F9	
=>!)%	"1%*%#)1#	:?F4E@ "F9	
=>!)#"	"1%!1S*(1#	7@C E6 "ZF9	
=>!)##	"1%!1S*(1#	7@C E6 "ZF9	
=>!)#S	"1%!1S*(1#	7@C E6 "ZF9	
=>!)#S	"1&&S S!!	=6ZL; F>AC 1 Š!>>	
=>!)#%	"1&&S S!!	=6ZL; F>AC 1 Š!>>	

Q	Q	Q	Q
Q"! "	"!#')'%"	DQE 4A	!
Q""	"!#')' *'"	>E2= 4A)Z# !Z& "z!H
Q"#	"!#')#1'"	>E2= 4A	"< & "z!H
Q"\$	"!#')S'"	>E2= 4A	"!< & "z!H
Q"&	"!#')' *'"	>E2= 4A	&< !Z& "z!H
Q"'	"!#&!)!(1\$	4C3@	"!! & "z!H
Q"("	"!#&%\$!"	>E2=	"> "" "z!H
Q")	"!#')#1'"	>E2= 4A	%Z< & "z!H
Q"*	"!#')' *'"	>E2= 4A	"!!< !Z& "z!H
Q"(!	"!#')' &'"	>E2= 4A	S\$ & "z!H
Q"("	"!#')' #&'"	>E2= 4A	#Z# & "z!H
Q"(%	"!#')' S1'"	>E2= 4A	##< & "z!H
Q"()	"!#')' (1'"	>E2= 4A	'Z< !Z& "z!H
Q"(*	"!#')' %"	DQE 4A	!
Q")!	"!#')' #&'"	>E2= 4A	#Z# & "z!H
Q")"	"!#&!' *'"	4C3@	## & "z!H
Q")#	"!#')' #1'"	>E2= 4A	%< & "z!H
Q")S	"!#')' #&'"	>E2= 4A	#Z# & "z!H
Q"*!	"!#')' #&'"	>E2= 4A	#Z# & "z!H
Q"*"	"!#&' ##	>E2= 4: 56	##< & S\$
Q"*	"!#&' S(1'"	4C3@	!Z6 & "z!H
Q#"	"!#!'" #1'"	4C3@	"!!< & "z!H
Q#S	"!#')' %"	DQE 4A	!
Q#%	"!## * (#'"	7D3-6	" & "z!H
Q#&	"!#')' (1'"	>E2= 4A	"!< !Z& "z!H
Q#'	"!#&' %\$'"	4C3@	!Z6 & "z!H
Q#("!#&' %\$'"	4C3@	!Z6 & "z!H
Q#)	"!#')' S1'"	>E2= 4A	#< & "z!H
Q#*	"!#')' S'"	>E2= 4A	"!< & "z!H
Q#!	"!#')' #&'"	>E2= 4A	#Z# & "z!H
Q#"	"!#')' S'"	>E2= 4A	"!< & "z!H
Q##	"!#')' #&'"	>E2= 4A	#Z# & "z!H
Q#&	"!#')' (1'"	>E2= 4A	%< !Z& "z!H
Q#'	"!#')' (1'"	>E2= 4A	%< !Z& "z!H
Q#("!#')' S'"	>E2= 4A	"!< & "z!H
Q#)	"!#&' %\$'"	4C3@	!Z6 & "z!H
Q#*	"!#&' %\$'"	4C3@	!Z6 & "z!H
Q##	"!#')' #1'"	>E2= 4A	"< & "z!H
Q%&	"!#')' *'"	>E2= 4A	&< !Z& "z!H
Q%&	"!#')' #&'"	>E2= 4A	#Z# & "z!H
Q&	"!#')' %\$'"	>E2= 4A	##< & "z!H
Q&*	"!#')' #&'"	>E2= 4A	"!!< & "z!H
Q&6	"!#')' S1'"	>E2= 4A	##< & "z!H
Q&%	"!#')' \$'"	>E2= 4A	%Z< !Z& "z!H
Q&#	"!#')' %\$'"	>E2= 4A	%< & "z!H
Q&\$	"!#')' S'"	>E2= 4A	"!< & "z!H
Q&%6	"!#')' %\$'"	>E2= 4A	%< & "z!H
Q&&	"!#')' #1'"	>E2= 4A	"< & "z!H
Q&&	"!#')' \$'"	>E2= 4A	%Z< !Z& "z!H
Q&&#	"!#')' \$'"	>E2= 4A	%Z< !Z& "z!H

Q	Q	Q	Q
Q&&	"!#')' \$'"	>E2= 4A	%Z< !Z& "z!H
Q&'	"!#')' #1'"	>E2= 4A	"< & "z!H
Q&("!#')' S'"	>E2= 4A	"!< & "z!H
Q&)	"!#')' \$'"	>E2= 4A	## & "z!H
Q&"	"!#&' &&#	>E2= 4: 56	") & #H
Q&#	"!#&' ##	>E2= 4: 56	## & #H
Q&\$	"!#')' #1'"	>E2= 4A	"< & "z!H
Q&%	"!#')' #&'"	>E2= 4A	#Z# & "z!H
Q&&	"!#')' (1'"	>E2= 4A	%! & "z!H
Q)!%	"!#&' %\$'"	4C3@	")! & "z!H
Q)!&	"!#&' %\$'"	4C3@	")! & "z!H
Q)!'	"!#&' %\$'"	4C3@	S\$ & "z!H
Q)! ("!#&' %\$'"	4C3@	S\$ & "z!H
Q)!)	"!#')' *'"	>E2= 4A)Z# !Z& "z!H
Q)! &	"!#')' *'"	>E2= 4A	"!!< !Z& "z!H
Q)!)'	"!#')' (&'"	>E2= 4A	"& !Z& "z!H
- K2D7C6C /			
E)!!	"!%\$%' *\$'"	K2D7C6L 7CC E619E/	
E)!"	"!%\$%' *\$'"	K2D7C6L 7CC E619E/	
E)# #	"!%\$%' *\$'"	K2D7C6L 9CC K@E2= @FAE	
5 3 `RcU GRcZR_e ARced <Gt#)7B)'			
- 4A24 E@ /			
4"\$	"!'" %\$S1'"	4C2: 4 4A ## A7	Š!~ & G
4"%	"!'" (1' %\$'"	7=> (& !A7	Š!~ "Z#G
4"%&	"!'" (1' (1'"	7=> !Z6F7	Š!~ #&G
4"%	"!'" (1' !#	7=> !Z#F7	Š!~ #&G
- 4@76 E@ /			
4) # %	fi "1)" * (1'"	AfB 4@76 E@ & A	
4) # &	fi "1)" * (1&	AfB 4@76 E@ ' A	
- 6DDE@ /			
Q" #	"!#')' \$'"	>E2= 4A	%Z< !Z& "z!H
Q" %6	"!#&' %\$#	>E2= 4: 56	%Z< & #H
Q" &	"!#&' %\$!!	>E2=	%!< "" "z!H
Q" ('	"!#')' (1'"	>E2= 4A	'Z< !Z& "z!H
Q" (("!#')' S1'"	>E2= 4A	ŠZ< & "z!H
Q" ##	"!#')' S\$'"	>E2= 4: 56	!Z) & "H
Q" &!	"!#&' &&#	>E2= 4: 56	") & #H
5 3 `RcU GRcZR_e ARced <Gt#)7B)'			
- 4A24 E@ /			
4"\$?@ 7H65		
4"%	"!'" (1) S1'"	7=> ')!!A7	Š!~ "Z&G
4"%&	"!'" & & *1'"	7=> !Z6F7	Š!~ #&G
4"%	"!'" (1) %\$'"	7=> !Z#F7	Š!~ %!G

Note : The components identified by shading and marked Δ are critical for safety. Replace only with the part numbers specified in the parts list.

4 7"

65Z@Z	A2E@Z	56DCAE@	6B-Z<
5S#)1("1**1S\$	5@6"D\$S#((
5S\$)1("1*!"1)\$	5@6"D\$	
5S%)1("1!)\$)	5@6F3D6"(1"&	
5S#)1("1*!"1)\$	5@6"D\$	
5S#)1("1*!"1)\$	5@6"D\$	
5S##)1("1**1S\$	5@6"D\$S#((
5S\$)1("1*!"1)\$	5@6"D\$	
5S#%)1("1!)\$)	5@6F3D6"(1"&	
5S\$)1("1*!"1)\$	5@6C5Z6B	
5S\$)1("1*!"1)\$	5@6"D\$	
	- :4/		
:4S!	'1(!%)!'1!"	:4E52"");7	
:4S!	'1(!%)!'1!"	:4E52"");7	
:4S#	'1(!%)!'1!"	:4E52"");7	
	- D@KE /		
;(SS ' "1%&1&%" D@GL 4E			
	- 4@=/		
=(SS	"1%*#)1#	:?F4EC	"F9
=(SS	"1%*#)1#	:?F4EC	"F9
	- A@GEC>@F-6 /		
ADSS# ' "1 \$1!! :4=?< "2 &G			
	- K2DDE@ /		
B\$!)1(#1!#&#&	K2DDE@ 37&	
B\$")1(#1!"1#	K2DDE@>D5!"1CE	
B\$#)1(#1#1!"(K2DDE@ #E!"*1@	
B\$!)1(#1!#&#&	K2DDE@ 37&	
B\$")1(#1!"1#	K2DDE@>D5!"1CE	
B\$#)1(#1#1!"(K2DDE@ #E!"*1@	
B\$#)1(#1!#&#&	K2DDE@ 37&	
B\$#)1(#1!"1#	K2DDE@>D5!"1CE	
B\$##)1(#1#1!"(K2DDE@ #E!"*1@	
B\$S)1(#1!"1!&	K2DDE@>D8!"1CE	
	- GDE@ /		
;C\$S	"1#')'%"	D@E 4A !	
;C\$S	"1#')'%"	D@E 4A !	
;C\$S	"1#')'%"	D@E 4A !	
C\$!	"1#')#1"	>E2= 4A "< &	"Z!H
C\$"	"1#')\$"	>E2= 4A ## &	"Z!H
C\$#	"1#')%"	>E2= 4A #! &	"Z!H
C\$\$	"1#')\$"	>E2= 4A ## &	"Z!H
C\$%	"1#')\$"	>E2= 4A ## &	"Z!H
C\$'	"1#')'%"	D@E 4A !	
C\$("1#&!)!(1\$	4C3@	"!! & "ZH

65Z@Z	A2E@Z	56DCAE@	6B-Z<
C\$)	"1##&&!!	D@: 5 ## #"	"Z!H
C\$!	"1#')#1"	>E2= 4A "< &	"Z!H
C\$"	"1#')\$"	>E2= 4A ## &	"Z!H
C\$#	"1#')%"	>E2= 4A #! &	"Z!H
C\$\$	"1#')\$"	>E2= 4A ## &	"Z!H
C\$%	"1#')\$"	>E2= 4A ## &	"Z!H
C\$"	"1#')'%"	D@E 4A !	
C\$("1#&!)!(1\$	4C3@	"!! & "ZH
C\$)	"1##&&!!	D@: 5 ## #"	"Z!H
C\$#	"1#')#1"	>E2= 4A "< &	"Z!H
C\$%	"1#')\$"	>E2= 4A ## &	"Z!H
C\$"	"1#')'%"	D@E 4A !	
C\$#	"1#')\$"	>E2= 4A ## &	"Z!H
C\$##	"1#')%"	>E2= 4A #! &	"Z!H
C\$S	"1#')\$"	>E2= 4A ## &	"Z!H
C\$%	"1#')\$"	>E2= 4A ## &	"Z!H
C\$#	"1#')'%"	D@E 4A !	
C\$#	"1#&!)!(1\$	4C3@	"!! & "ZH
C\$#	"1##&&!!	D@: 5 ## #"	"Z!H
C\$\$	"1#')#1"	>E2= 4A %Z< &	"Z!H
C\$\$	"1#&!*\$!!	4C3@	"> & "ZH
C\$\$\$	"1#&1%(1"	4C3@	"< & "ZH
C\$\$%	"1#&1%(1"	4C3@	"< & "ZH
C\$\$&	"1#&!(S&)"	4C3@	% & "ZH
C\$\$	"1##&&!!	D@: 5 "!! #"	"Z!H
C\$\$	"1##&&!!	D@: 5 "!! #"	"Z!H
C\$%	"1#')#1"	>E2= 4A #Z< &	"Z!H
C\$&	"1#')#1"	>E2= 4A #Z< &	"Z!H
C\$!	"1#')#1"	>E2= 4A #Z< &	"Z!H
C\$"	"1#')#1"	>E2= 4A "< &	"Z!H
	- GDE@ GC 23-6 /		
C\$S	"1#&'&1"	GDL 25L >E2= 7=> ""!>	
fi 2!"%!&t""t2 7" 3`RcU 4` ^ajVeV			
	%#)'##1!"	9@5GL =65	
	- 4A24EC /		
4*)#	"1!'%'&"	G6E	"!!F7 #Z!" #&G
4*)\$	"1!#"%"!!	4C2: 4 %!A7	"!Z!" &G
4*)%	"1!#"#1!!	4C2: 4 !Z"F7	"!Z!" &G
4%!&	"1""\$*#%"	4C2: 4 !Z!%F7	#Z!" #&G
	- 4@76EC /		
4!*)	fi "1&%&(1"	A7L 4@76EC %A	
4%!&	' fi "1&1)\$"	A 7L 4@76EC 1A7@C	
4%&	' fi "1"*1#*1"	A 7L 4@76EC 1A4 3@C5' &A	
4%\$	"1'*&*"&"	E2314@E24E	
	- 5@6 /		
5*))1("1!"1)*	5@6C5Z6B#	
5*)\$)1("1!)#"	5@6E-9-&*	

Āčžč	Āčžč@	5DICAĒ@	Āčžč
Ā%	"1#1)Ā"	>Ē= 49A	%!< & "ž!H
Ā%&	"1#1)Ā"	>Ē= 49A	%!< & "ž!H
Ā%	"1#1)Ā"	>Ē= 49A	%!< & "ž!H
Ā%	"1#1)Ā"	>Ē= 49A	%!< & "ž!H
Ā%	"1#1)#1"	>Ē= 49A	"< & "ž!H
Ā%	"1#1)S1"	>Ē= 49A	##< & "ž!H
Ā&	"1#1)S1"	>Ē= 49A	##< & "ž!H
Ā!!	"1#1!##!!	Ē49A	(& & "ž!H
Ā!"	"1#1!##!!	Ē49A	(& & "ž!H
Ā!#	"1#1!##!!	Ē49A	(& & "ž!H
Ā!\$	"1#1!##!!	Ē49A	(& & "ž!H
Ā!%	"1#1!##!!	Ē49A	(& & "ž!H
Ā!&	"1#1!##!!	Ē49A	"!! & "ž!H
Ā!("1#1!##!!	Ē49A	"!! & "ž!H
Ā!)	"1#1!##!!	Ē49A	"!! & "ž!H
Ā!*	"1#1!##!!	Ē49A	"!! & "ž!H
Ā!"	"1#1!##!!	Ē49A	"!! & "ž!H
Ā""	"1#1!##!!	Ē49A	(& & "ž!H
Ā"#	"1#1!##!!	Ē49A	"!! & "ž!H
Ā"\$	"1#1!##!!	Ē49A	(& & "ž!H
Ā"%	"1#1!##!!	Ē49A	"!! & "ž!H
Ā"&	"1#1!##!!	Ē49A	(& & "ž!H
Ā""	"1#1!##!!	Ē49A	(& & "ž!H
Ā"("1#1!##!!	Ē49A	(& & "ž!H
Ā")	"1#1!##!!	Ē49A	(& & "ž!H
Ā"*	"1#1!##!!	Ē49A	"!! & "ž!H
Ā#	"1#1!##!!	Ē49A	"!! & "ž!H
Ā##	"1#1!##!!	Ē49A	"!! & "ž!H
Ā#\$	"1#1!##!!	Ē49A	"!! & "ž!H
Ā#%	"1#1!##!!	Ē49A	(& & "ž!H
Ā#&	"1#1!##!!	Ē49A	"!! & "ž!H
Ā#	"1#1!##!!	Ē49A	(& & "ž!H
Ā#("1#1!##!!	Ē49A	(& & "ž!H
Ā#)	"1#1!##!!	Ē49A	(& & "ž!H
Ā\$	"1#1!##!!	Ē49A	"!! & "ž!H
Ā\$	"1#1)!"	>Ē= 49A	"!! & "ž!H
Ā\$#	"1#1)!"	>Ē= 49A	"!! & "ž!H
Ā\$%	"1#1!##!!	Ē49A	(& & "ž!H
Ā\$&	"1#1!##!!	Ē49A	"!! & "ž!H
Ā\$	"1#1!##!!	Ē49A	"!! & "ž!H
Ā\$	"1#1!##!!	Ē49A	(& & "ž!H
Ā\$	"1#1!##!!	Ē49A	"!! & "ž!H
Ā\$*	"1#1)!"	>Ē= 49A	')< & "ž!H
Ā\$%	"1#1)!"	>Ē= 49A	')< & "ž!H
Ā\$	"1#1)!"	>Ē= 49A	Œ< !ž& "ž!H
Ā\$	"1#1)%"	ĒĒE 49A	!
Ā\$#	"1#1)#1"	>Ē= 49A	"< & "ž!H
Ā\$	"1#1)%"	>Ē= 49A	%< & "ž!H
Ā\$&	"1#1)S1"	>Ē= 49A	##< & "ž!H

Āčžč	Āčžč@	5DICAĒ@	Āčžč
Ā&&	"1#1)S1"	>Ē= 49A	##< & "ž!H
Ā&	"1#1)#1"	>Ē= 49A	"< & "ž!H
Ā&	"1#1)%"	>Ē= 49A	%< & "ž!H
Ā&	"1#1)S1"	>Ē= 49A	##< & "ž!H
Ā&	"1#1)#1"	>Ē= 49A	"< & "ž!H
Ā'!	"1#1)%"	>Ē= 49A	%< & "ž!H
Ā'"	"1#1)#1"	>Ē= 49A	Œ< & "ž!H
Ā'#	"1#1)#1"	>Ē= 49A	Œ< & "ž!H
Ā'\$	"1#1)!&"	>Ē= 49A	% & "ž!H

fi 2!%!&!#!#2 G> 3`RcU 4`^ajVeV

%\$#) &!"	DĀĀ>S)/L A.L.DHif
- 4242E@/	
4%"	"1#1%&" 66E %F7 #ž!" S&G
4%#	"1"%"&" 4Ā: 49A!žF7 #&G
4%S	"1!(1)#1" 4Ā: 49A!žF7 "!ž!" "G
4%%	"1!(1)S1" 66E "F7 #ž!" "!G
4%'	"1"1)S1!! 4Ā: 4 !ž!%F7 &!G
4%("1"%"&" 4Ā: 49A!žF7 #&G
4%)	"1#1*%" 66E "F7 #ž!" &G
4%*	"1!(1)S1" 66E "F7 #ž!" "!G
4%!&	"1)S1&)" >J=Ā !žF7 "!ž!" #&G
4%"	"1!(1)#1" 4Ā: 49A!žF7 "!ž!" "G
4%#	"1)S1&)" >J=Ā !žF7 "!ž!" #&G
4%S	"1!(1)#1" 4Ā: 49A!žF7 "!ž!" "G
4%%	"1"1%&" >J=Ā !žF7 "!ž!" #&G
- 4?6E@/	
4%"	fi "1&%&!" AĀL 4?6E@ (A
4%#	fi "1&%&!" AĀL 4?6E@ SA
4%S	fi "1((1)#1" 4?6E@L 3ĀĀ5E@3ĀĀ5)A
- 4@=/	
=%"	"1%&*)1# :?F4E@ "F9
=%#	"1%&*)1# :?F4E@ "F9
- E2DDE@/	
B%")1(#!"1)1# E2DDE@>D!"1CE
B%#)1(#!"1)1# E2DDE@>D!"1CE
B%S)1(#!"1)1# E2DDE@>D!"1CE
B%%)1(#!"1)1!& E2DDE@>D!"1CE
B%&)1(#!"1)1)1# E2DDE@>D!"1CE
B%')1(#!"1)1!& E2DDE@>D!"1CE
B%()1(#!"1)1)1# E2DDE@>D!"1CE
B%))1(#!"1)1!& E2DDE@>D!"1CE
B%*)1(#!"1)1)1# E2DDE@>D!"1CE
B%!&)1(#!"1)1)1!& E2DDE@>D!"1CE
B%")1(#!"1%&!& E2DDE@>D!"1CE



C6Z@Z	A2CEZ@	56DCAE@	C6-Z<
B*%#)1(#1!%&!%	EC2DDE@ #D&&"	
B*%S)1(#1!"!1#	EC2DDE@ >D5!"1CE	
B*%%)1(#1!"!1!&	EC2DDE@ >D5!"1CE	
- (GDDE@/			
C*%"	"1#%\$1\$1""	4C3@	" & "Z!H
C*%#	"1#'1)##1""	>E2= 49A)# & "Z!H
C*%S	"1#'1)"*1""	>E2= 49A)! & "Z!H
C*%%	"1#'1)\$%1""	>E2= 49A	"# & "Z!H
C*%&	"1#'1)\$*1""	>E2= 49A	\$\$ & "Z!H
C*%'	"1#'1)!&""	>E2= 49A	% & "Z!H
C*%)	"1#'1)"&""	>E2= 49A	\$\$ & "Z!H
C*%*	"1#'1)!&""	>E2= 49A	% & "Z!H
C*%!	"1#'1)!&""	>E2= 49A	% & "Z!H
C*%"	"1#%\$1\$1\$1""	4C3@	"! & "Z!H
C*%#	"1#%\$1\$1\$1""	4C3@	"! & "Z!H
C*%S	"1#%\$1\$1\$1""	4C3@	"! & "Z!H
C*%%	"1#%\$1\$1\$1""	4C3@	"! & "Z!H
C*%&	"1#%\$1\$1\$1""	4C3@	"! & "Z!H
C*%'	"1#%\$1\$1\$1""	4C3@	"! & "Z!H
C*%("1#%\$1\$1\$1""	4C3@	"! & "Z!H
C*%)	"1#%\$1\$1\$1""	4C3@	"! & "Z!H
C*%*	"1#'1)\$*1""	>E2= 49A	\$\$ & "Z!H
C*%#	"1#'1)##1""	>E2= 49A	"< & "Z!H
C*%#	"1#'1)!1""	>E2= 49A	## & "Z!H
C*%##	"1#'1)!1""	>E2= 49A	## & "Z!H
C*%#S	"1#'1)##1""	>E2= 49A	"< & "Z!H
C*%#%	"1#'1)\$*1""	>E2= 49A	\$\$ & "Z!H
C*%#&	"1#%\$1&##	>E2= @:56	%! & #H
C*%#	"1#'1)\$*1""	>E2= 49A	\$\$ & "Z!H
C*%#("1#'1)\$*1""	>E2= 49A	\$\$ & "Z!H
C*%#	"1#'1)##1""	>E2= 49A	"< & "Z!H
C*%\$	"1#'1)!*1""	>E2= 49A	"!! & "Z!H
C*%\$	"1#'1)!*1""	>E2= 49A	"!! & "Z!H
C*%\$#	"1#'1)"(1""	>E2= 49A	%! & "Z!H
C*%\$\$	"1#'1)"(1""	>E2= 49A	%! & "Z!H

>:D46==2?6@FD

' "1&"1%\$1\$ # DHE4L AFD9124 A46C
 "1%&1&!1"" 4@-L 4Q6 %Z&>9
 ' "1()\$!)\$1"" 4@5L A46C1HE9 7-#6C
)1&)1"! 7@E65 3E7 6F "" 1<G#7B' F'
)1&)1&\$\$"! 7@E65 3E7 6F% "" 1<G#7B' E<G\$#7B' E<Z/
)1&)1&\$\$# 7@E65 3E7 6F% "" 1<G#7B' 3L<G\$#7B' 3'
 ' "1%\$1\$()\$1# EC2DDE@>C 2DDL 7-J32k 1?1! #ZK#%
 1<G#7B' /
 ' "1%\$1\$%%# EC2DDE@>C 2DDL 7-J32k 1?1! #ZK#%
 1<G\$#7B' /
 "1%)1"" D62-6C1%Z# #4/
 "1%(1"" D62-6C1)4/
 ')1%&1\$ 567-6E @ J@61J#C4#=# 1<G#7B' /
 ' "1%&1%!)1## 567-6E @ J@61J#C4# 1<G\$#7B' /
 ')1%\$1!"1"" ?6k 2DDL1?2#*1>
 "1%*1\$1\$1"" 4@-L ?2 C@E @
 ' "1%#%)1"" 4@-L 568HD?81<G#7B' /
 ' "1%#%)1"" 4@-L 568HD?81<G\$#7B' /
 ' "1#&1*%!)1"" 4A 2DDL 9 81 C@E2861<G\$#7B' /
 ' "1#&1*%!)1# 4A 2DDL 9 81 C@E2861<G#7B' /
 ')1(\$&!(*!& A4FC6 EF361H' =K' !/ 1<G\$#7B' /
 ')1(\$&!*!1& A4FC6 EF361H' =I' !/ 1<G#7B' /
 "1%&1!%!! >286L C@E23-6 5 D; " &> E
 "1%&1\$!! >286L 5 D; " !>> E

2446DD@C:6D 2?5 A24<28:? 8 >2E6C:2=D

f%!*%#(!!# 4FD @ FA6C <G\$#7B' 36Z-ZF
 f%!*%#(1!# 4FD @ =@6C <G\$#7B' 36Z-ZF
 f%!(1&%!" :?5 G 5F2= 4CE@ <G\$#7B' 36Z-ZF
 f%!"\$")\$1" :?5 G 5F2= 4CE@ <G#7B' 36
 %!%!(1#" 38 AC@6E @ <G\$#7B' 36Z-ZF
 %!#1"!)1" 38 AC@6E @ <G#7B' 36
 %!"\$"#%"" :7KFE @ >2F2= 86C-2Z7FC< D98C6/
 <G#Z\$#7B' 6
 %!"\$"#%# :7KFE @ >2F2= :E2= 2/ <G#Z\$#7B' 6
 %!"\$"#%\$:7KFE @ >2F2= ?@H8 2Z7A@HF86E
 D65 D97 ?? D952? D9D2? D9
 <G#Z\$#7B' 6
 %!"\$"#% :7KFE @ >2F2= 86C-2Z E2= 2Z7C64E
 5E49 <G#Z\$#7B' 3
 %!"\$"#%& :7KFE @ >2F2= 68: D9 <G\$#7B' 3
 %!"\$"#% " :7KFE @ >2F2= 3F-8C 2Z7A6968: D9
 9F8C 2Z7CHD 2Z7A@: D9 <G\$#7B' <
 %!"\$"#%(" :7KFE @ >2F2= 68: D9 <G\$#7B' F

C6>@E6 4@>> 2?56C

"1%!)1\$1"" C6@6 4@>256C1C1*%&

TRACE

A new TV Repair Assistance Tool that combines ease of use and powerful PC software tools to allow you to save valuable time during many TV repairs.



The TRACE interface connects to the PC's serial port. It provides connection to the TV's I²C bus and can be provided with an InfraRed transmitter (optional).

The interface is powered by a standard 9 V PP3 battery for portable use, and can also be powered by an external 9V/25mA DC power supply.

The TRACE software that is supplied with the interface allows you to:

- Read, restore and compare NVM contents via the I²C bus
- Acknowledge check of all I²C devices in the TV set
- Read Error Codes (emulation of the Error Reader tool)

With the optional IR Add-on kit, the following features can be added:

- Remote Commander emulation
- User programmable Functional Check through Infrared
- Fast and documented Test Mode setting of all Sony TV chassis

Additional features such as Adjustments and Troubleshooting are available in chassis-dependent software modules. Please contact your local Sony Service organisation for the latest information.

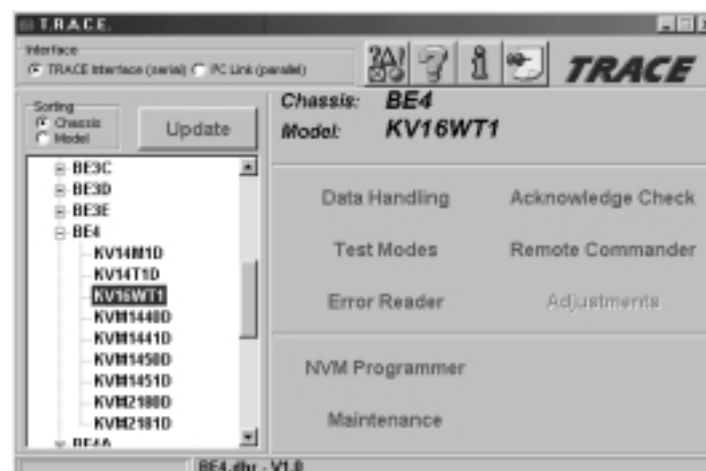

Note: For workshops already using the existing I²C Link parallel port interface (9-948-320-30), this software can be used as well, replacing the TV Data Handling software (9-948-340-50), but Error Reader and IR functions can only be accessed with the TRACE interface.

Partnumbers: TRACE Starter Kit (TRACE interface + software): 9-948-320-70
 TRACE Software (for users of the I²C Link interface): 9-948-340-80
 TRACE IR Add-on (IR interface + Remote Commander software): 9-948-320-80

PC requirements: IBM-compatible PC with operating system Windows95, Windows98, or WindowsNT*.

* WindowsNT only supported with TRACE interface